



THE ART OF
Summer in
Mara

THE ART OF
Summer in
Mara

GTM
EDICIONES

THE ART OF SUMMER IN MARA

Primera edición: enero de 2020

Publicación de GTM Ediciones, C.B. Camino Fuente de la Mora 9, 1-117. 28050 Madrid.

© Todas las imágenes incluidas en el libro son propiedad de Chibig Studio.

© 2020 GTM Ediciones

© 2020 Chibig S. L. U

Textos: Diego Freire

2D Art: Miriam Barea, Fran Segura, Carolina Ibáñez.

3D Model: Paloma Pipeleers

Cinemáticas: Ciervo Alto

Iconos: Danalyn Reyes

Maquetación: Juan Tejerina Villamuera

Realización técnica: GTM Ediciones

ISBN: 978-84-120759-8-4

Depósito legal: M-40559-2019

Printed in Spain

Cualquier forma de reproducción, distribución, comunicación pública o transformación de esta obra solo puede ser realizada con la autorización de sus titulares, salvo excepción prevista por la ley. Dirijase a CEDRO (Centro Español de Derechos Reprográficos) si necesita fotocopiar o escanear algún fragmento de esta obra (www.conlicencia.com; 91 702 19 70 / 93 272 04 47)

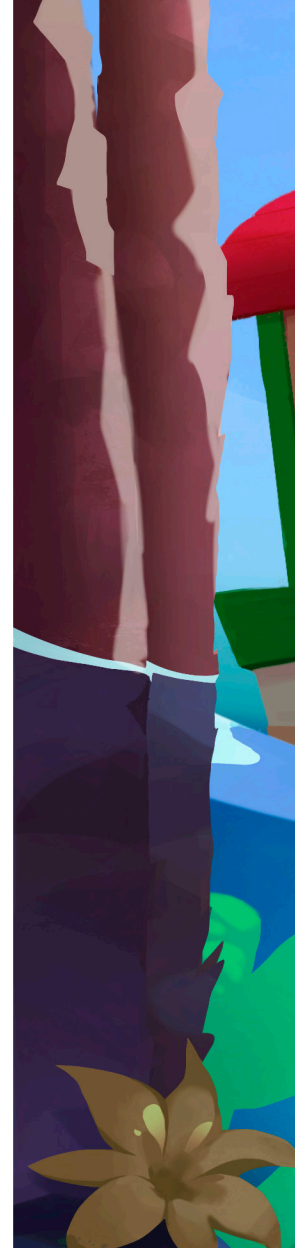



CHARACTERS	4
FACTIONS	54
MARA	72
ANIMATION	114
PROMOTIONAL	144
FAN ART	164





THE ART OF SUMMER IN MARA

...

Characters

CHAPTER I

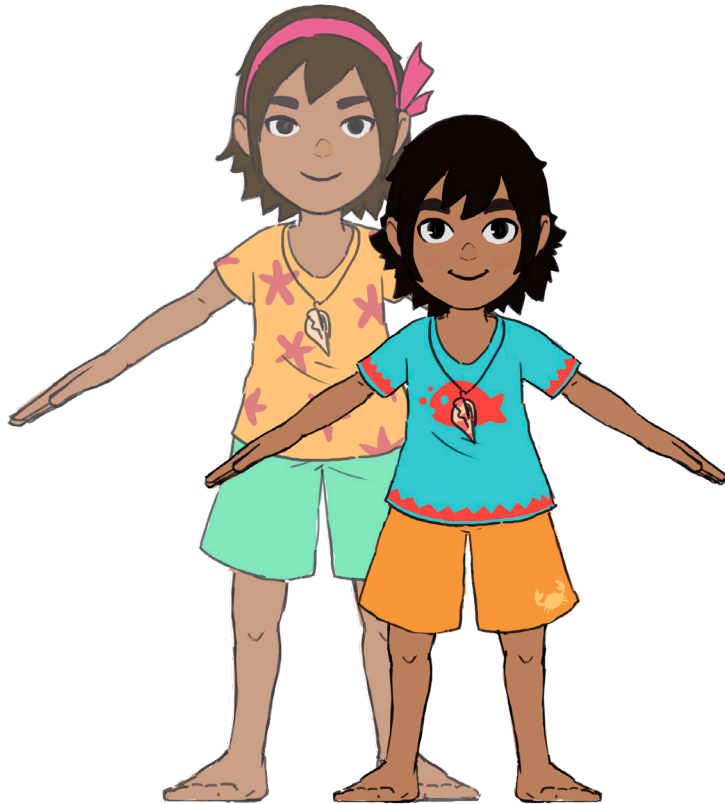

Koa

“When I grow up, I want to see all those things Yaya always talks about. Different people, big boats, islands where the land never ends... I would like to make lots of friends, too, so I can show them my island and I hope they want to show me their houses. Are there other seas like Mara? Does their breeze smell the same?”

— Koa, another morning staring at the clouds.



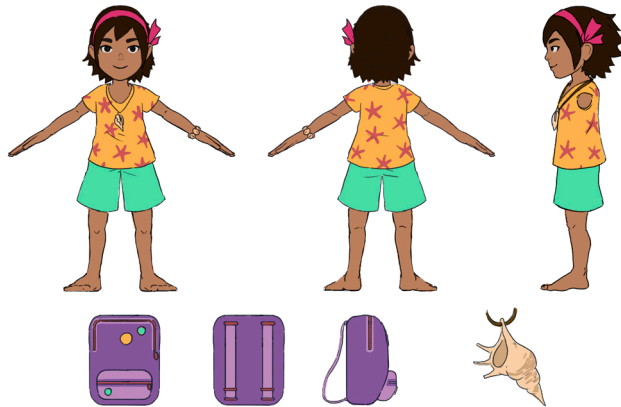

Koa's clothes

"I made them myself. Do you like it?"

— Koa

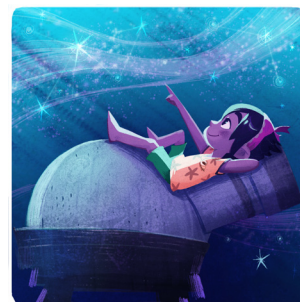

Koa's abilities



Koa's expressions

“When she’s angry, she’s hungry. When she’s hungry, she gets angry, too”.

— Yaya Haku

THE ART OF SUMMER IN MARA



Koa's spare time

"Shoes? I don't need shoes. Just my backpack".

—Koa





Haku

“She has endless patience. Even when I know I’m behaving badly, she never yells at me. She just lifts a finger, frowns and talks to me in a calm voice. That’s really scary, actually. But then she laughs and everything is alright again. I promised her that when I’m as old as she is, I’ll behave better”.

— **Koa**, looking at Yaya Haku picking oranges.



The Idea of Haku

“When I was younger, I needed the uniform. Now, I prefer a big pamela hat”.

— Haku

THE ART OF SUMMER IN MARA







Napopo

“Napopo is really cheerful. Napopo is always in a hurry. Napopo is very shy and doesn’t like strangers. Napopo scares me sometimes. But Napopo always has a surprise for me, so I really like being around her. Napopo is really, really cute, but she doesn’t talk a lot. Napopo helps me with everything and never doubts. When people ask me what Napopo is, I always tell them that she is my friend”.



— Koa, looking at Napopo sitting on the seashore

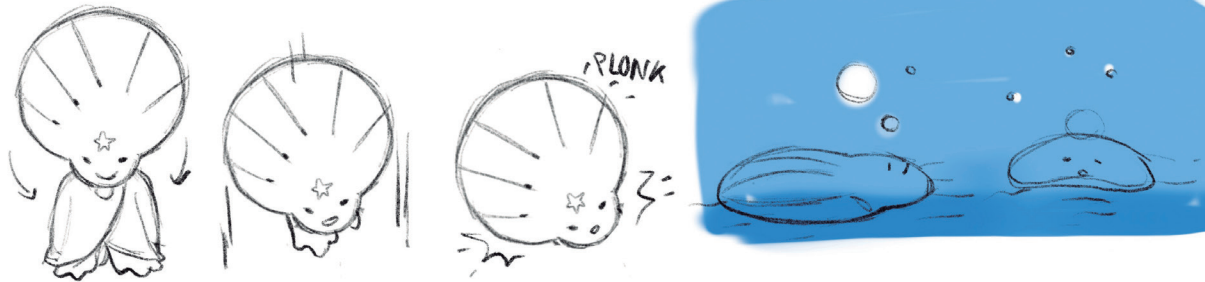

Napopo's Family

"I don't know much about her family, but I picture something like this".

— Koa

THE ART OF SUMMER IN MARA



Other Sea Creatures

"I wonder if there are other sea creatures like Napopo in Mara. I hope so!"

— Koa



Napopo's paintings

"The best painter in all of Mara!"
—Koa





Noho



“He talks a lot. So much. He doesn’t even breathe. He just keeps talking. He fills my silences. I would never get tired of hearing him”.

— Caleb, between silences.

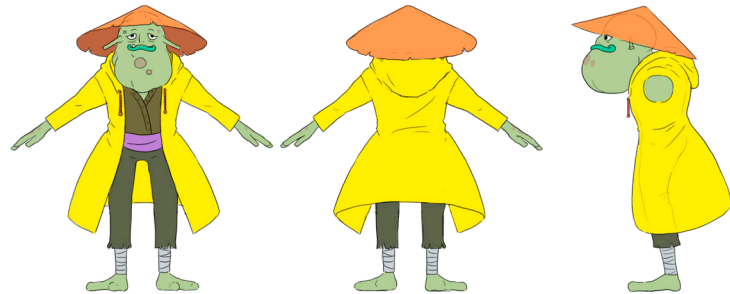



Caleb

“Once, when we didn’t know each other very well yet, Caleb appeared in my house with a huge fish. He never told me where he got it. It was gigantic. I decided right there that I wanted to travel with him...”

— Noho, not even breathing once.

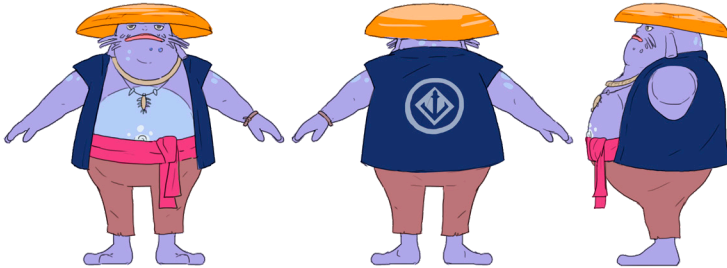



Onzo

“I’m gonna tell you something: a cat-child doesn’t have it simple. When we are born in Miah we’re suddenly part of this huge universe. It’s riveting, don’t you think? We have to look out for ourselves. All my ancestors did it. So do I! When I’m in doubt, I read my diary and see they doubted too. That calms me down. Every cat-child is different, but we’re all the same”.

— Onzo, showing you a page of his diary.







Blu

“I don’t want to say anything negative about anyone, but Blu... I don’t know him very well, but... It’s like... Who believes in spirits nowadays? But there’s something in his eyes that... You know...”

— Taka, now that you ask.







Edegan

“You know what? People complain a lot. If they knew how this world really works, they would like me so much more. I just do my job. And I’m pretty good at doing it. I’m great with finances and numbers. I can tell you the value of almost anything with just taking a glance at it. It’s really easy. The people on this island, however, insist that there’re things without price. Well! There’s nothing that a big check can’t buy”.

—Edegan, looking at his reflection.



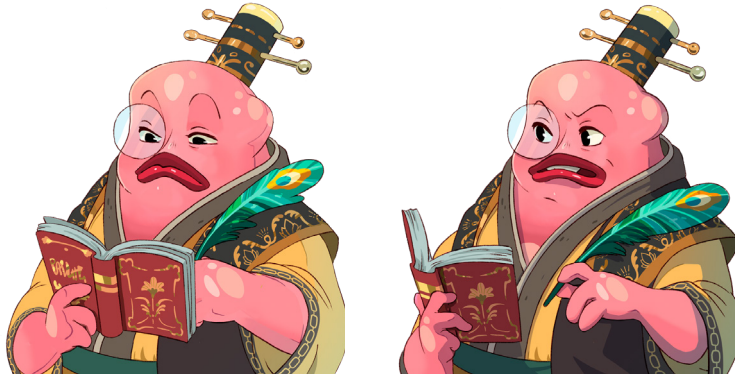

Edegan's Feather

"My dad bought this bank for me, why do you ask? Why yes, of course I started my business from the ground up".

— Edegan



Taka

“I used to be scared of fire. When I'd get near a fire and feel the heat, I'd get really scared. Taka, however, can hold a burning frying pan with his bare hands. When he cooks, flames appear everywhere and it looks like everything will burn. But he's always in control. Nobody in the whole ocean of Mara can cook like him. And he keeps doing it because he feels like he's still improving”.

—Brram, looking at his uncle on the beach.



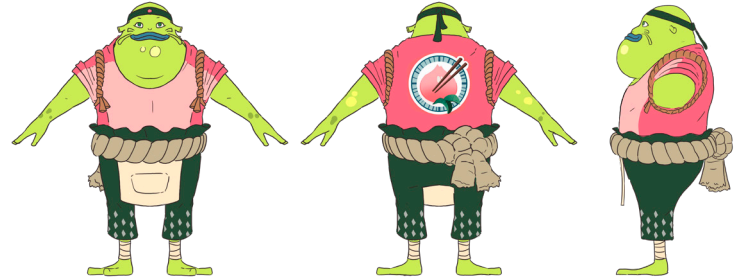

Taka's Apron

"I clean this thing every day but every day, when I finish my shift, It's dirty again".

—Taka



Brram

“He works too much. Why does he work that much? He makes me look bad. I’m not saying that he shouldn’t work that much, but he should think of the rest of us. He carries that backpack, delivering his uncle’s food, but he also cooks and does strange experiments with the food. I don’t think that’s normal. Also, you can’t say a single word to him! He blushes like a pyre. That kid is a mess”.

—Mayo, after taking a nap.



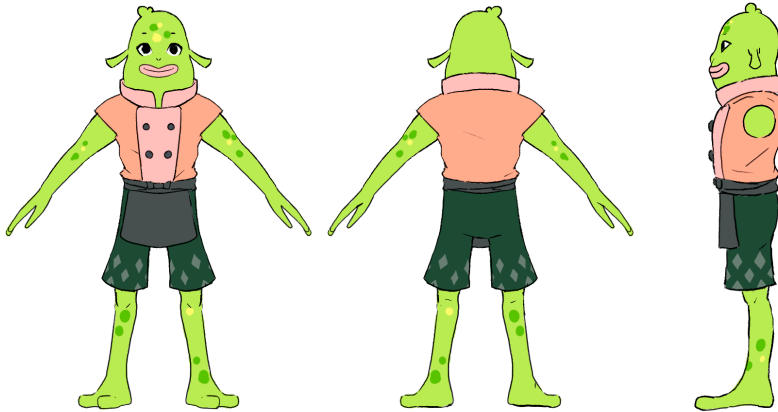

Brram's Cuisine

"I hope someday I can travel to different planets and meet different people and I hope they want to try my dishes".

—Brram



Awan

“He has a unique taste. I think his whole personality revolves around one thing: getting others to like him through his work. I don’t think that’s healthy, rather the opposite. There’s something in his dishes that I don’t find anywhere else. Some anguish, or sadness. But something sublime, too. He’s not aware of his titanic effort. I wish I could find the words to calm down his anxiety”.

—Aquila, after eating an Ankora salad





Awan's Taste

"He makes anything you want if he has the right ingredients. Like in a midnight diner".

—Mayo



Mayo

“Nobody can speak for me, you know? I’m unique in every way. I’ve been in almost any place in the universe. Being a waitress is just another job. I’ve been a robber, a labourer, a PE teacher and a caretaker. They fired me from all these jobs. Here, at least, Awan pays me well and I can save up to become a pirate. That’s it! I’ve wanted to be a pirate since I saw one, two or three years ago. It must be fun”.

—Mayo, sitting on a messy table.



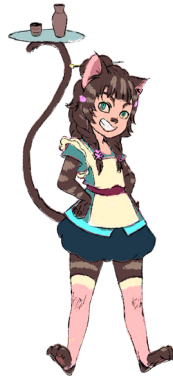

Mayo's Job

"Don't trust anyone who wants to work just because. Working is something that you do because someone told you to. If you like it, you better quit. If you enjoy it, you will hate it in a month. Trust me: a robber fired me once".

—Mayo





Akaji

“You will recognize her because of her hair. It’s not even the most amazing thing about her, but it draws attention. When you look closely, you start to see the details. Her superhuman ability to lift weight. She’s always dirty, but she doesn’t care. She can make a bun with one hand. She can eat like the world is going to end, but she always forget to”.

—Litio, at dawn.





Akaji's Hammer

"This was my mothers. I inherited it when she decide to stop working. Nowadays, they don't make hammers like this".

—Akaji

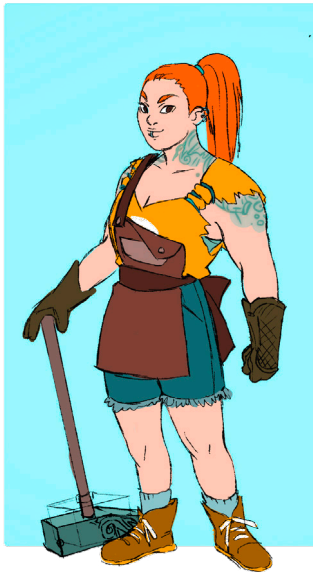



Aquila

“My uncle doesn’t like to talk about himself or where he comes from. He’s, like all the other elit, a discreet person. I remember when I was a child, he always disappeared from the table after dinner, and went to the library. He didn’t care about the things that the other elit discussed. They ignored him, almost like a child. That’s why he left Deva, he couldn’t stand it anymore”.

—**Rigatta**, stopping her boat in open sea.

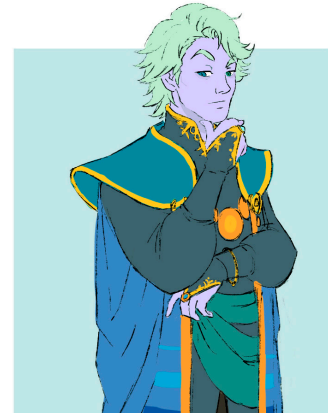



Saimi

“I’m taller than Saimi, but she isn’t all that small either. I always was jealous of her intelligence but in a good way. I wanted to be better because of her. Later, I wanted to be better for her. Without Saimi, I would never have gotten this far. I would like to ask her if she can forgive me. I hope she’s aware of how much she mattered to me. I always was taller than Saimi, but I never will be as big as she”.

—Haku, feeling the morning breeze.





Pilly Tilly Milly



“Oh, those sisters. I’m terrified of them. They hate me and they have some really good merch”.

—Noho, while asking for a drink in Taka’s beach bar.

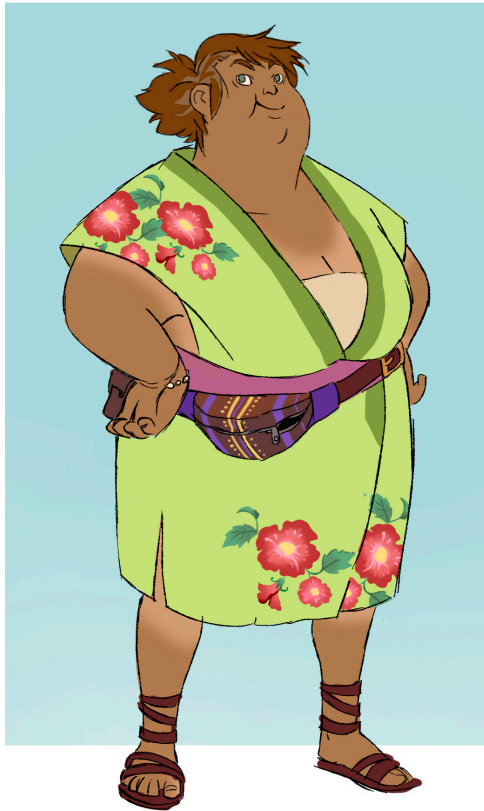



Dunna

“Dunna? She’s the best! She uses so many tools to make all these machines work and make those noises they make. Alright, I don’t know what she does exactly, but I really, really, really like her”.

—**Jet**, while looking to a photograph.



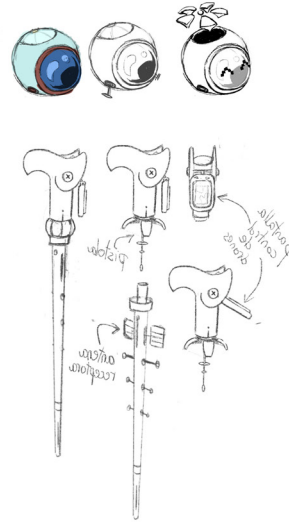
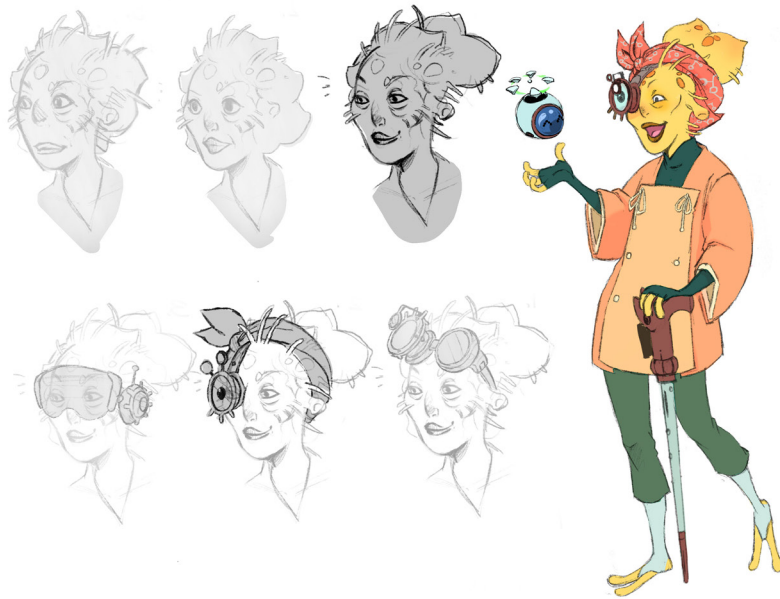



Mûn

“I studied so hard in the Academy that I deserve this vacation. You can’t be a future interstellar explorer without resting a bit”.

—Mûn, before taking a nap.

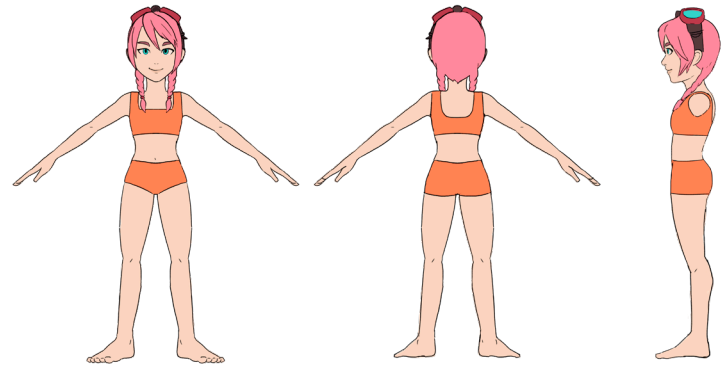

Litio

“That friendly fool. He’s useless with everything related with being a pirate. I don’t know how he got that crew and how they can respect him. Maybe because he’s so big. Or because of that amazing hair he has”.

—Mr. Ecco, while cleaning his silverware.





Mr. Ecco

“Ah, yes, the best pirate in the entire ocean, I heard about him. He’s a legend, from his humble beginnings as a young buccanneer to his actual designation as King of the Pirates. The envy of the whole ocean”.

—Mr. Ecco, posing as another person.



Rigatta

“That kid is a natural finding treasures. She finds its aura miles away, she knows which have value and which don’t. I really don’t know what she’s doing on this swamp planet”.

—Aquila, looking at a new statue.

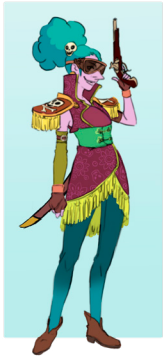



Ereti

“I’ve never met her, actually. I never got to meet her, but I know everything about Ereti. I know she puts two fingers on her forehead when she’s tired. Or that she wrinkles her nose when she’s angry. Do you want to know how I know that? Her father wouldn’t shut up about her. That’s why”.

— Dunna, adjusting a screw

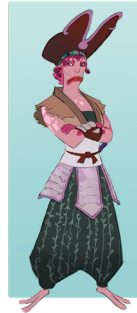

Taima

“Me? But I was just passing through. Oh, look, a coin. A pretty coin. It’s very lovely. Where are you from little guy? I hope nobody is looking for you. Hey if anyone asks, please tell them that I have it! What a pity, I hope it’s not lost”.

— Taima, trying to focus.





CB

“All CB units are characterized by two factors: their brute force and their lack of curiosity. Feeding them well and keeping them entertained is the base for a perfect development and integration in the elit society. They are perfect for manual labor”.

—Baron Pligich, elit scientist.



Fink

“Fink... Fink... I can’t remember her very well. Another subordinate, like many others, I presume. I assume she does her work and that’s all. The engine doesn’t know about every gear that makes it work, why should I know about a simple bureaucrat?”

—Von Ern Bolgost, Baron

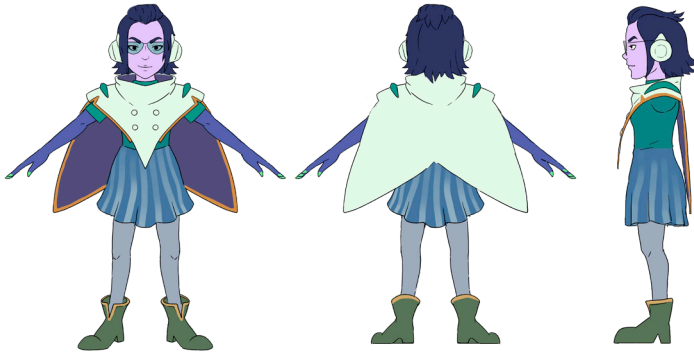



Baron

“Baron of the Elit, Sir of the region of Vandor, Son of Von Ern, Explorer of planets, Expropriator of mana, Seeker of resources, Fallen in Disgrace, Elevated in Purpose, Bolgost. That’s my full name”.

—**Baron**, after dressing up.



Inhabitants

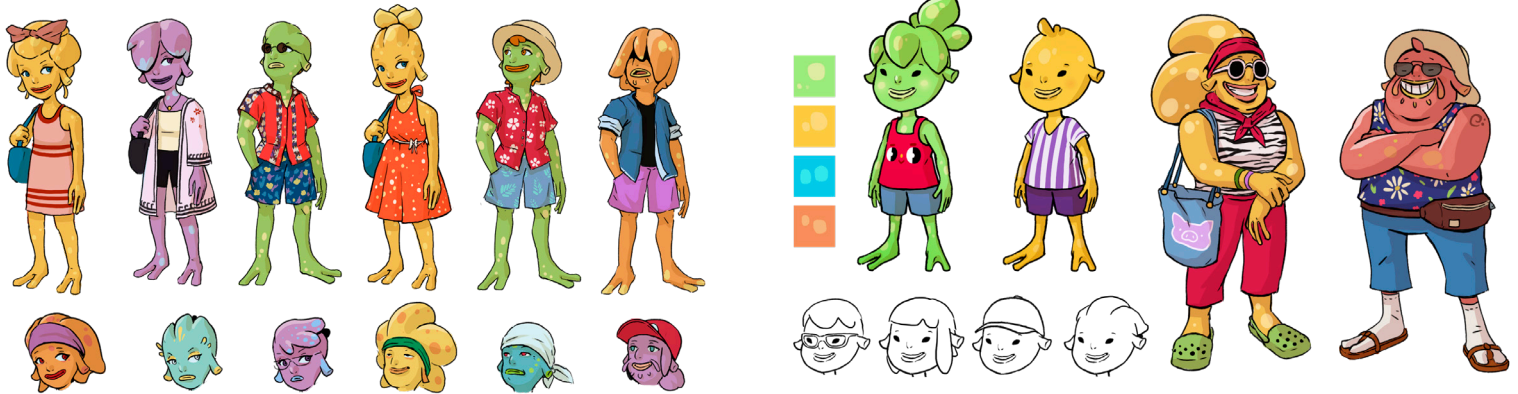

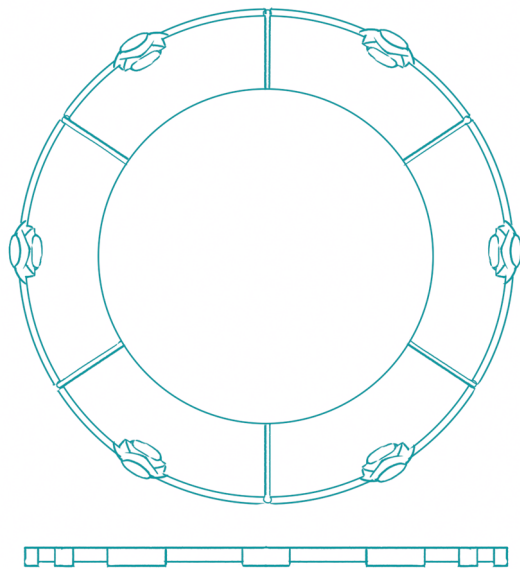
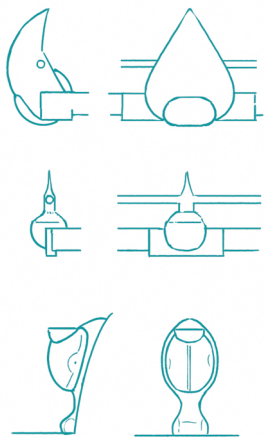
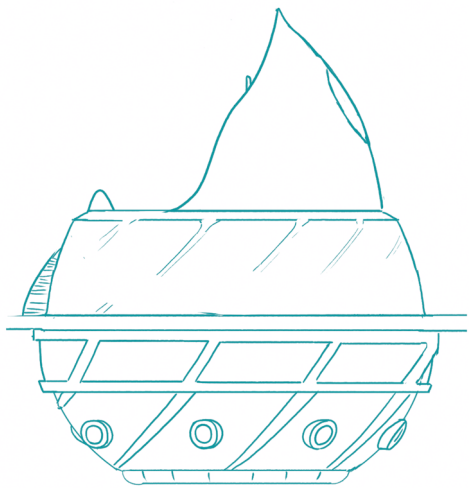
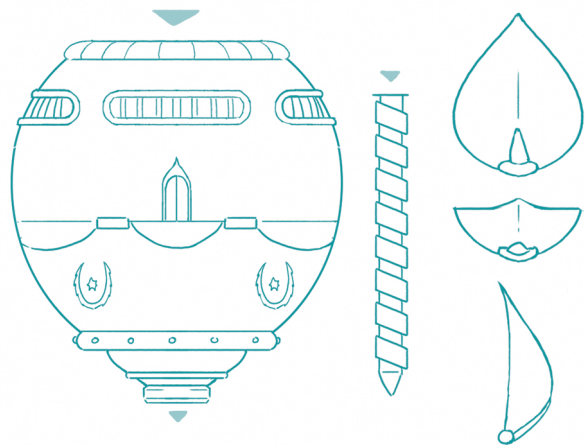
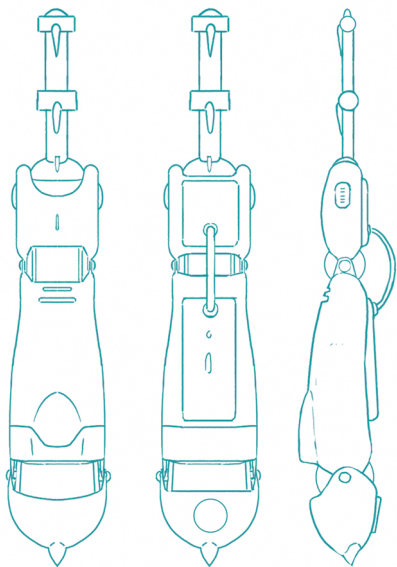
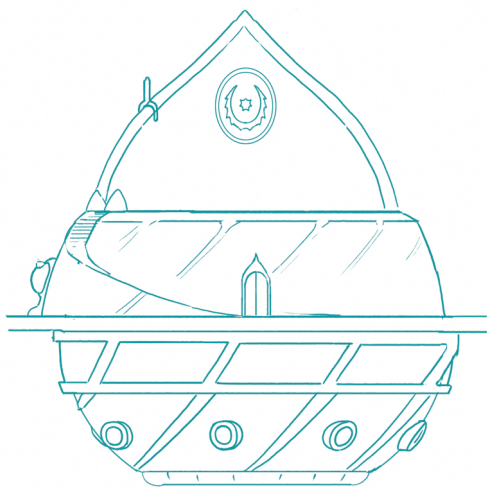



THE ART OF SUMMER IN MARA

...
Factions

CHAPTER II



Pirates

“We don’t have a unique style, you know? We “acquire” our things by looting, but we don’t mess with other inhabitants. In the old days, pirates were the terror of the ocean. Now, instead, we only do races and mess with each other. You know why? Because of the Navy. Those good-for-nothing quidos that used to chase us. They aren’t here anymore, and still...”

—Ereti, looking through a spyglass.



Ereti's ship





Mr. Ecco's ship

“An excellent piece of work. This ship was built not for looting or racing, but for looking good when I'm sailing. And I look amazing on it. You have to see me when the wind blows and I let my moustache free swirling in the air. Oh, what a feeling!”

—Mr. Ecco, finishing a cup of tea while wearing his pajamas.



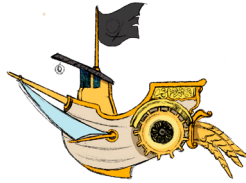
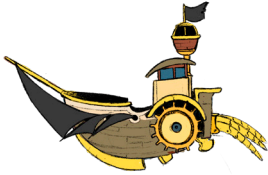



Rigatta's ship

"She just appeared with her ship one day. I don't know where she got it. It's something very... new. Those sails. The design. Everything on it is so... different. I don't like it. It feels wrong".

—Caleb, not wanting to speak too much.





Setting sail!

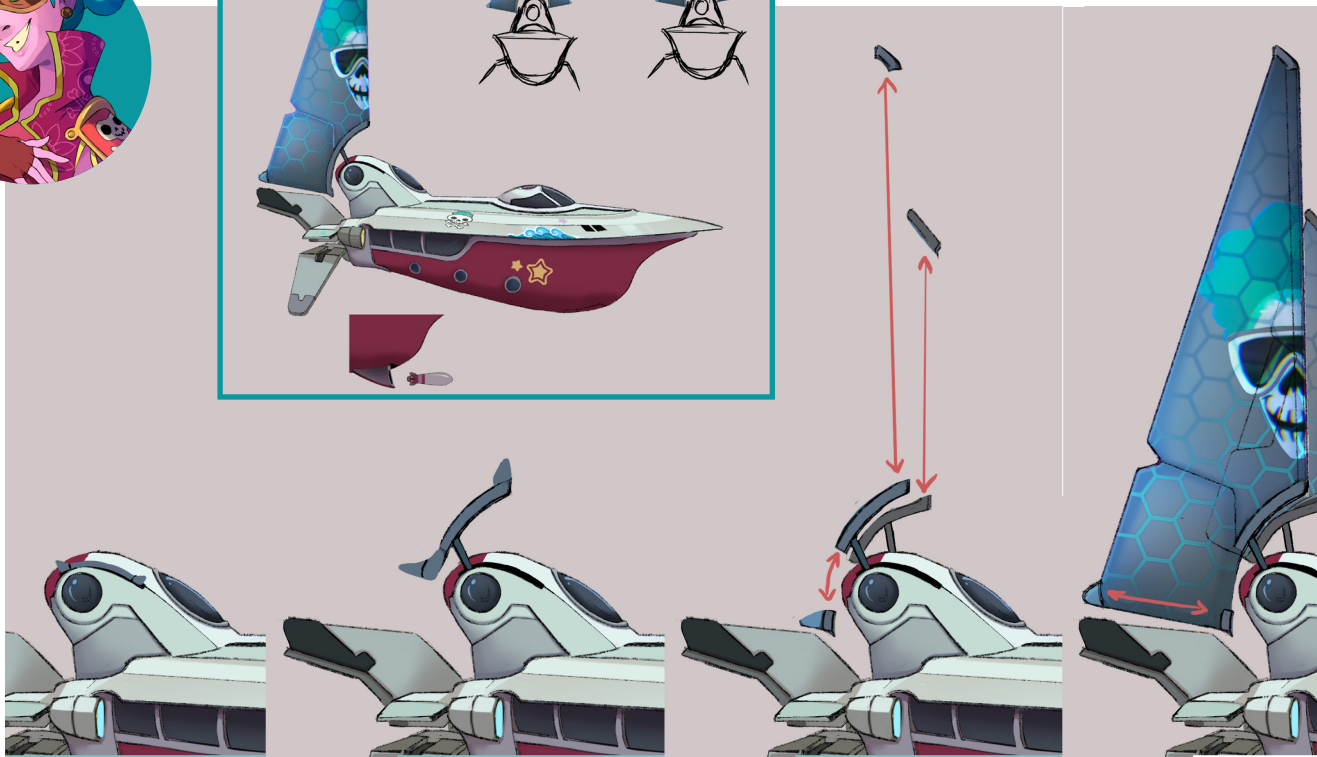



Litio's ship

“I inherited it from another pirate. Well, actually, it was more like a gift. I don't know why, he just gave it to me. Maybe he was tired. I understand him, don't get me wrong, but I really love this life. My crew is very loyal and they always follow my orders. So I'm really happy”.

—Litio, greeting another sailor.





Taima's ship

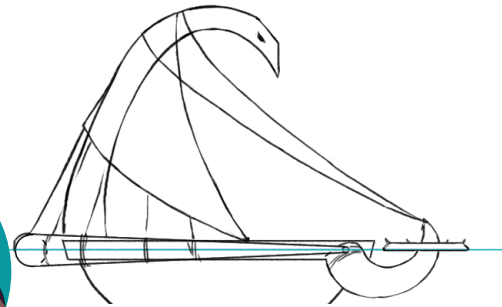
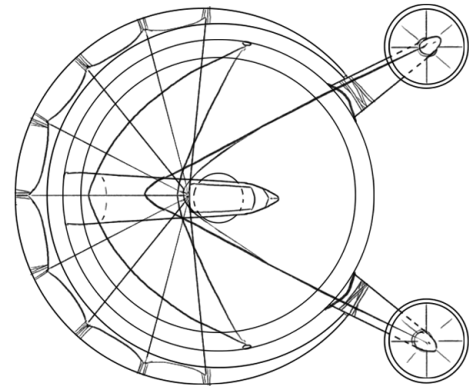



Elit

“We’re not a civilization. That’s an idea for tribes and nations far behind our progress. We’re a megacorporation. We look for profit and get what we want, whatever the cost. Yes, we have this dadiva. It’s a gift, it’s a curse. It expands our life expectancy, but it also make us weak. It doesn’t matter: we can take profit from it too”.

—Baron, almost yelling.

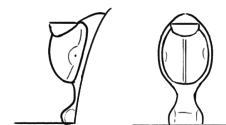
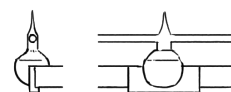
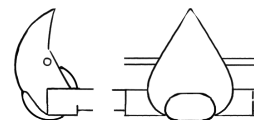
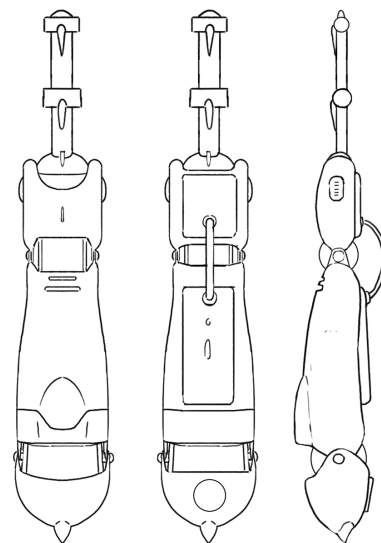

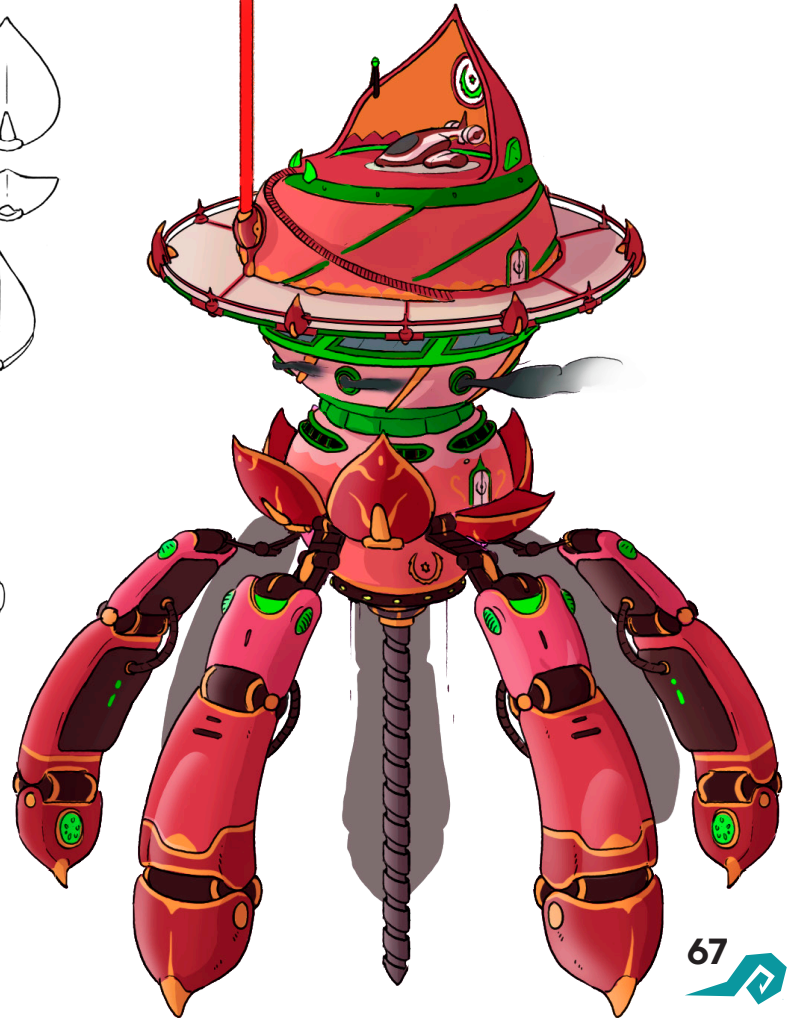
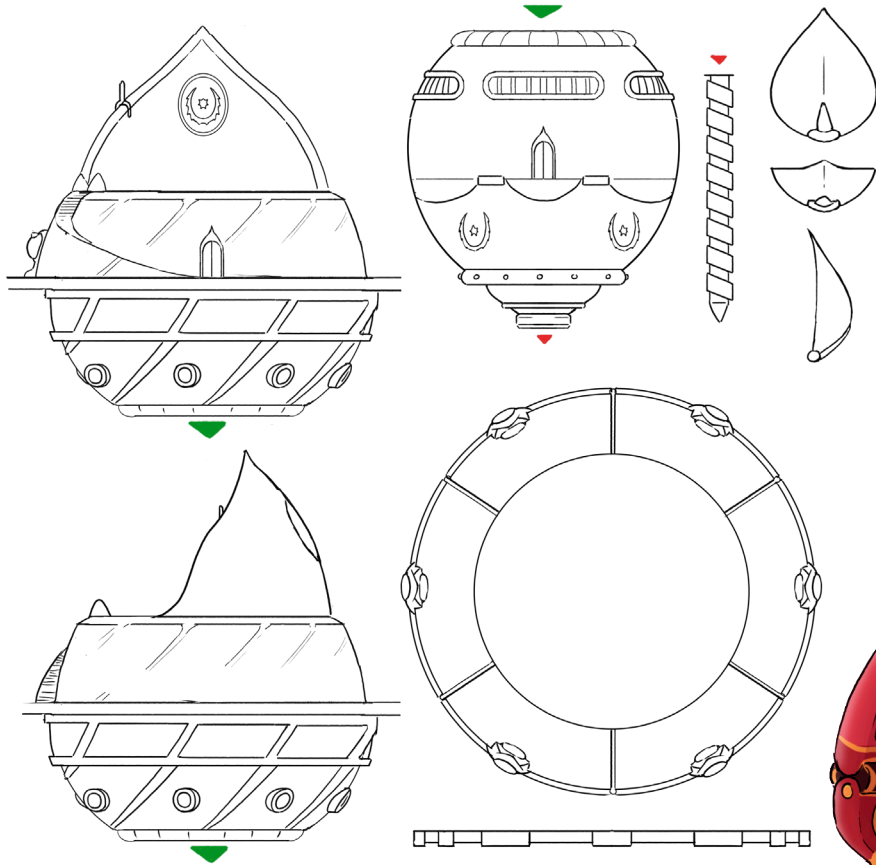



Navy

We're a non-violent organization. That's the first thing that you should know. The Qū Navy was made to defend and protect anyone that lives in Mara, no matter their race, faith or anything else. Justice comes first, and then peace will appear. But we shouldn't be naive. Who watches over us? We have to be honest and try our best to be better".

—Commander of the Qū Navy,
thinking about his crew.

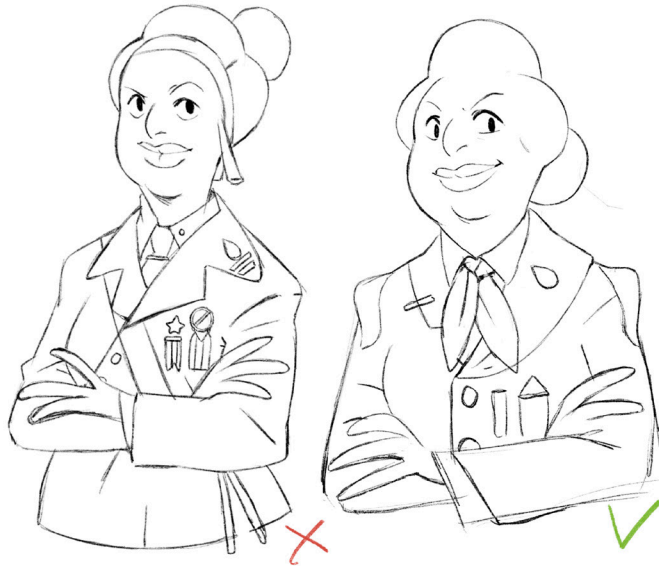

Haku

“You will be nothing if you keep behaving like this. You have to study, you have to attend your classes, you have to stop being so lazy. For the love of Mara, you’re really great, but you can be so much better!”

—Haku’s Teacher in Navy Academy

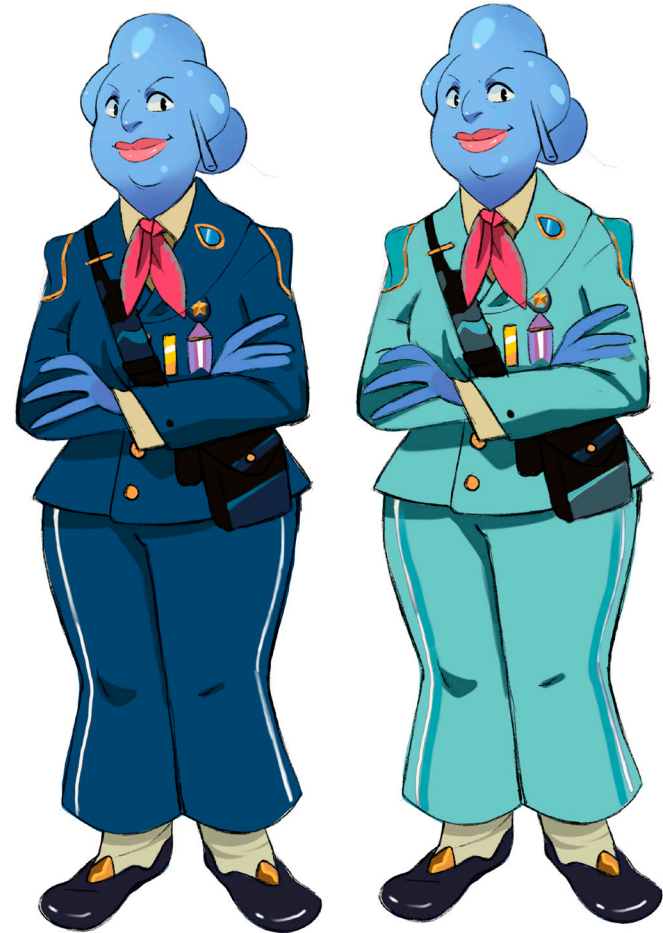

THE ART OF SUMMER IN MARA



Jet

“Now, listen to me closely: you won’t be the helmsman on this ship. This is my ship now and these people trust me, so if you think that I will let you even get close to that ship’s steer just because of your pretty face you...Oh, by Mara, you’re right”.

—Captain of Mara, Second Vessel, First Fleet

Saimi

“Why do you want so much brains if you don’t have any brawn? You have to be strong, not only smart. Do you think you can beat a pirate with just your intelligence? Wrong!”

—PE Teacher, looking at Saimi looking at her glasses



Dunna

“I’m not even mad at you for almost blowing up the whole building. It’s not like you did it on purpose, right? Just, please, promise me that you won’t do this again. Please, not again... Why can’t I believe you?”

—President of the Qū Navy Academy

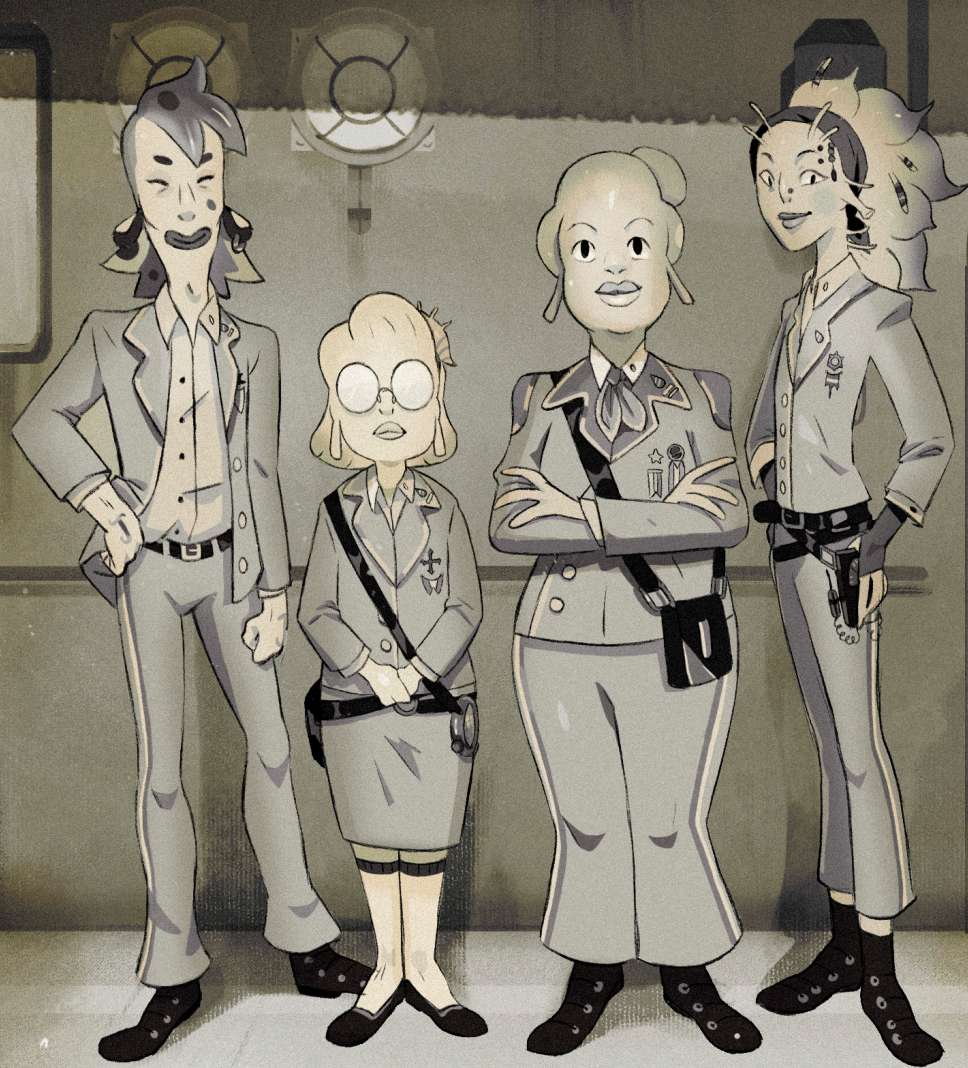



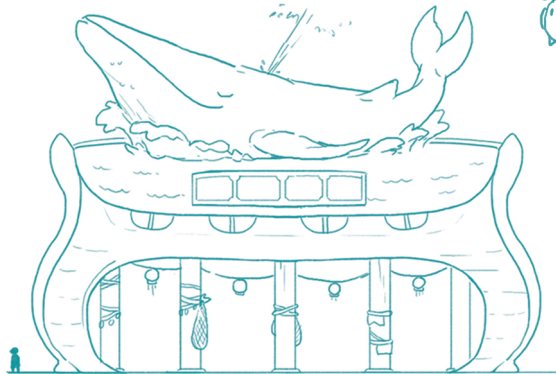
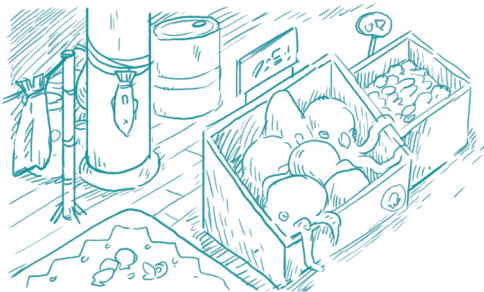
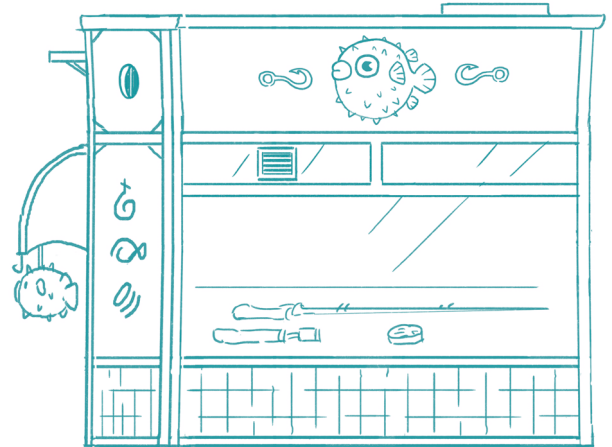
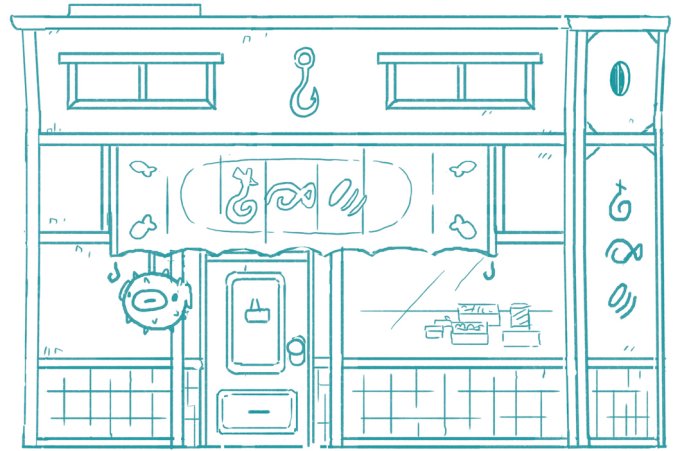
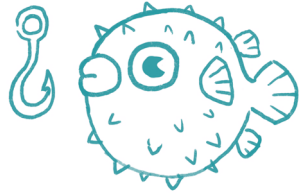

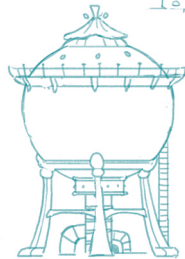
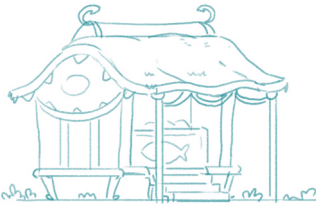
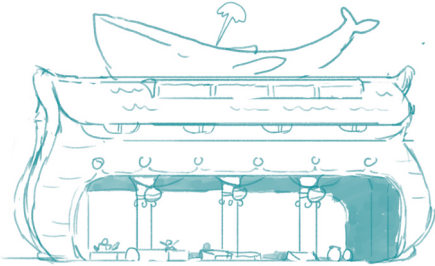
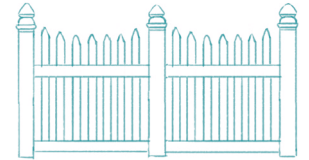
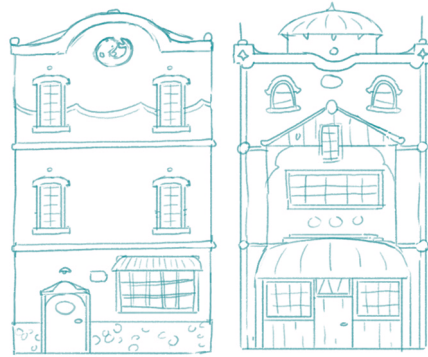

THE ART OF SUMMER IN MARA

...
Mara

CHAPTER III



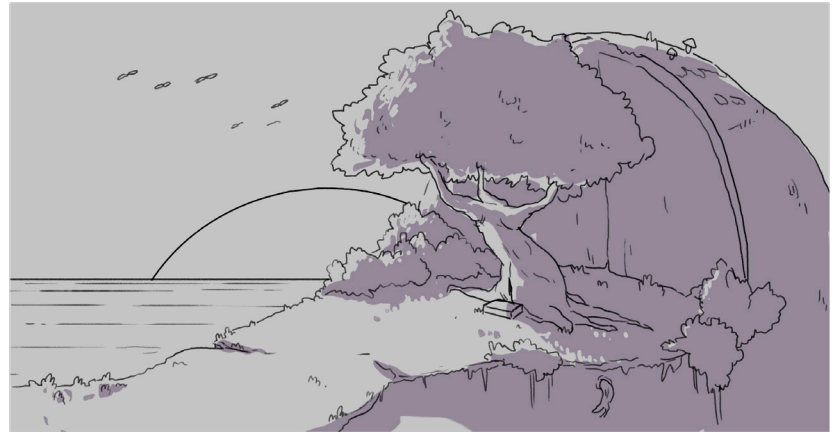
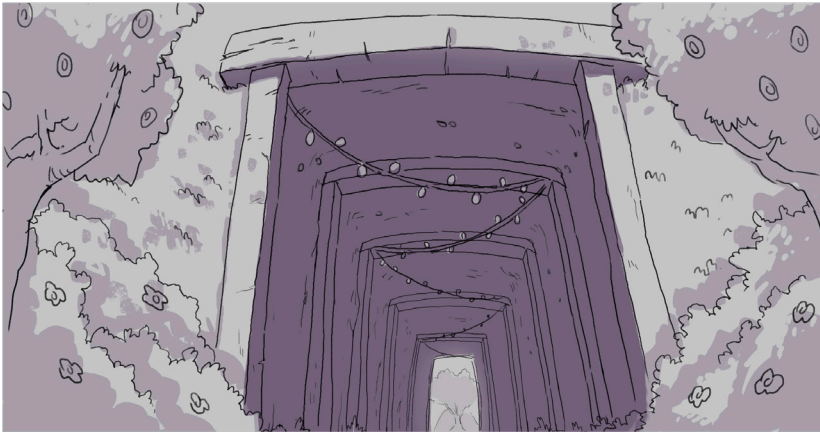
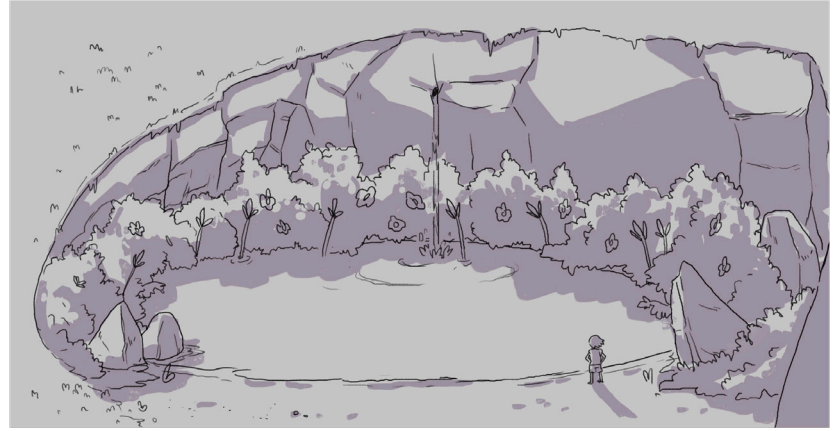

Home Island

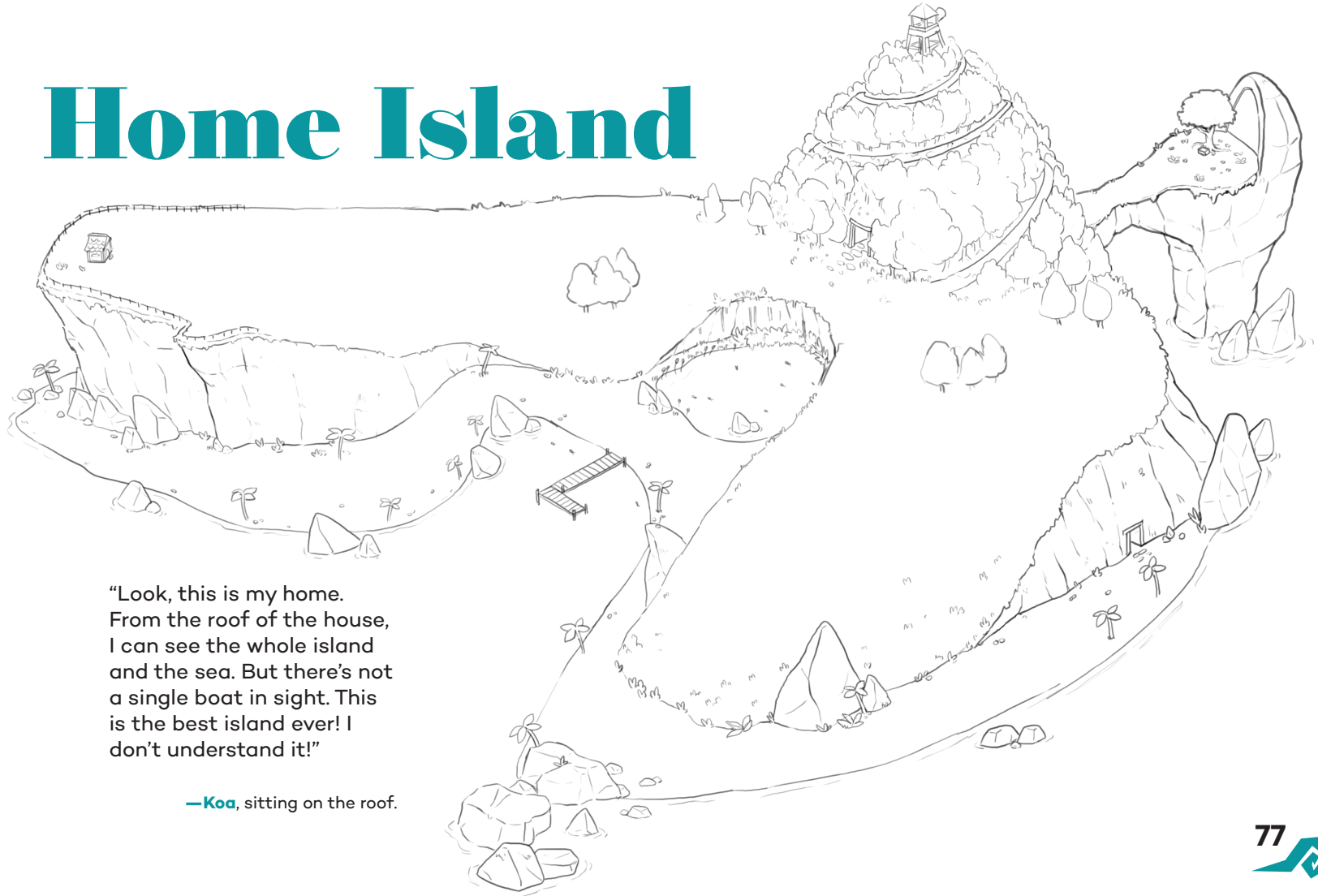

“Look, this is my home.
From the roof of the house,
I can see the whole island
and the sea. But there’s not
a single boat in sight. This
is the best island ever! I
don’t understand it!”

—Koa, sitting on the roof.

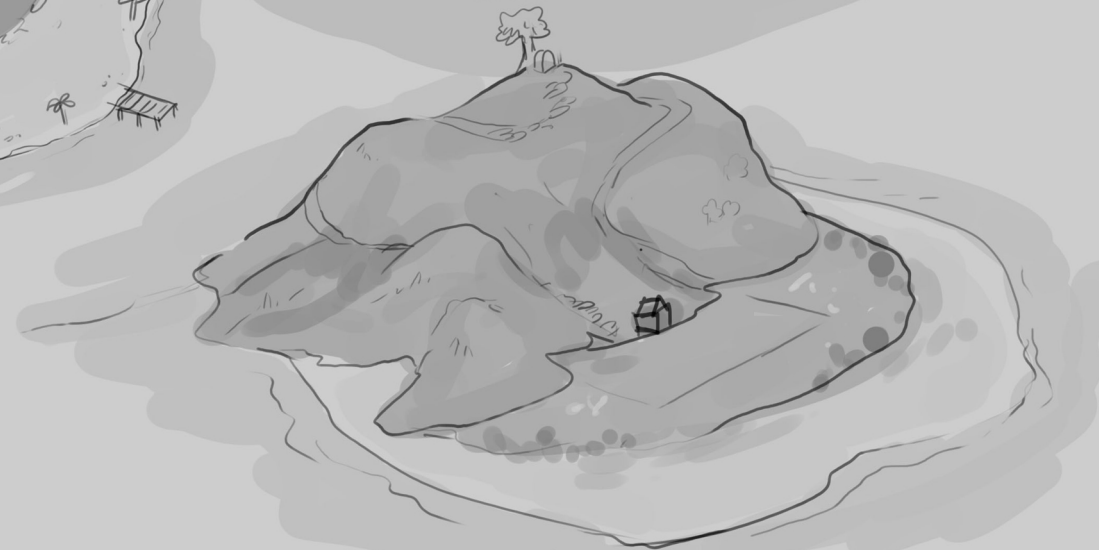
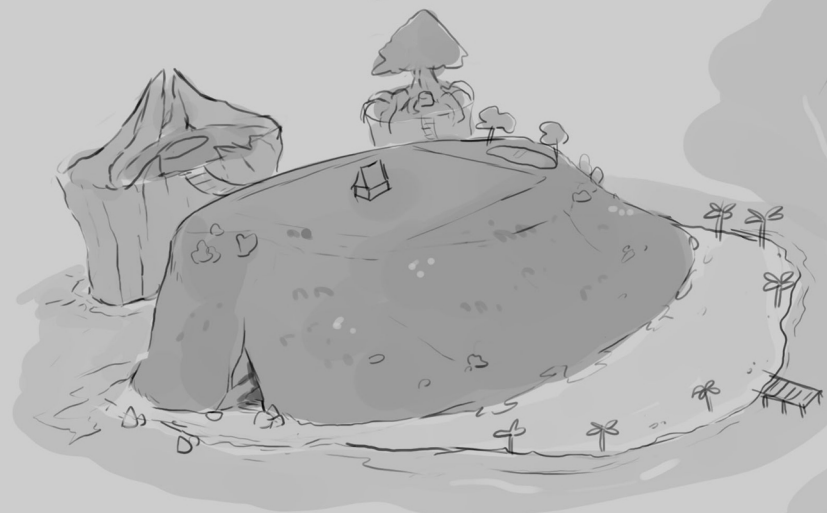
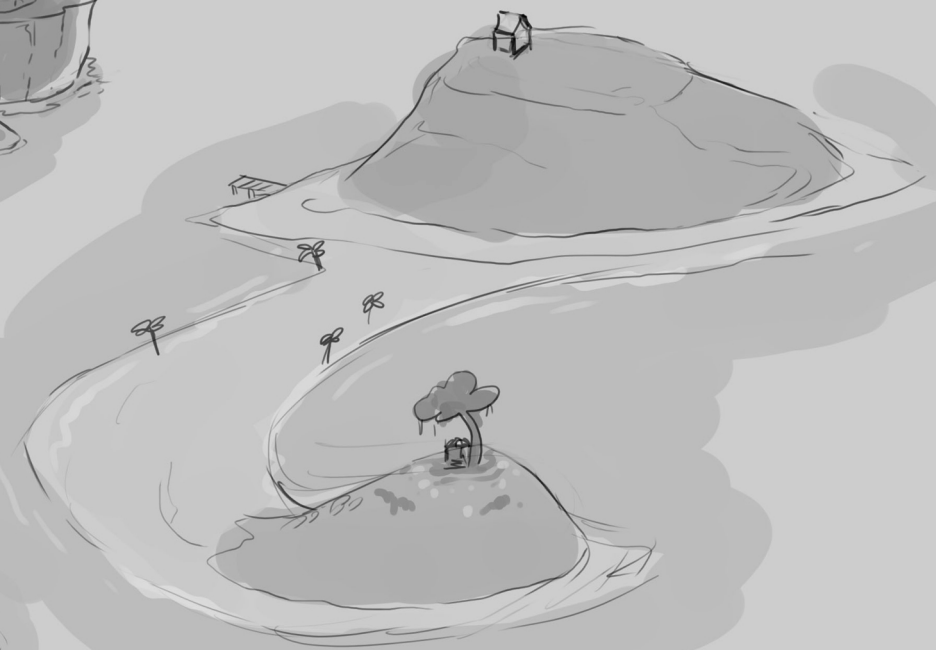
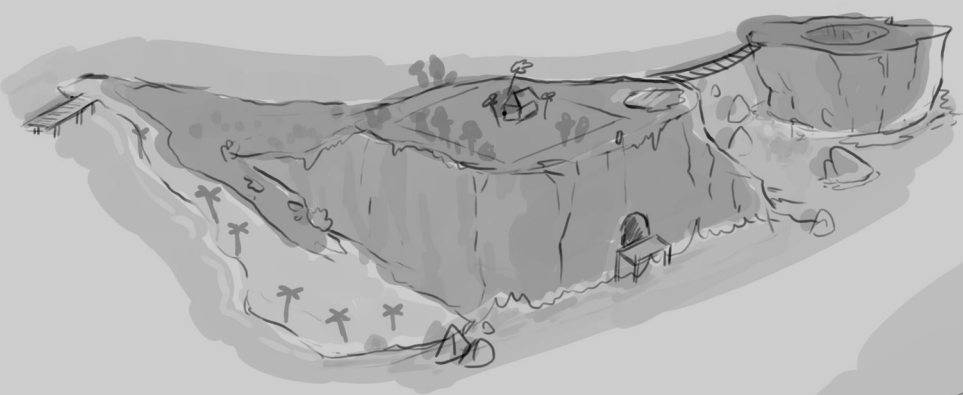

Home Island

“I think about my island as a place that was always here. When Yaya arrived, the island already was here. And when I leave the island, the island waits patiently for me. I want to share it with everyone, with every animal. Because this is not only mine, it’s for everyone who wants to take care of it”.

—Koa, chasing a pig.





CARACOLA



ANZUELO



ANCLA

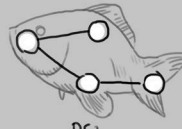

PET

ÁRBOL
HABILIDADES



OLA



ÁRBOL

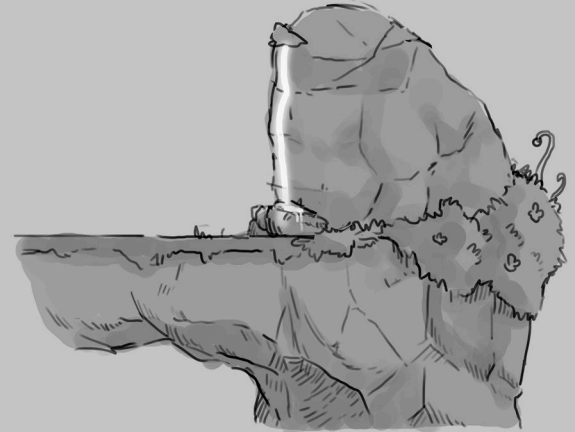

The Door

“She never let me get close the door. One day, after coming back with the boat, she asked me to pick the crystalids from the chest. I wasn’t allowed to get close to the chest before either, so that was strange. We sat in front of the door and she told me once more that story about the guardians.

The story went something like this: a long time ago, there were four guardians in Mara. They kept the ocean free from any danger. Each one of them were at a different place, all connected by a spiral. In the end, they isolated themselves on different islands until they disappeared. Yaya always used to tell stories like this”.

—Koa, touching the door.

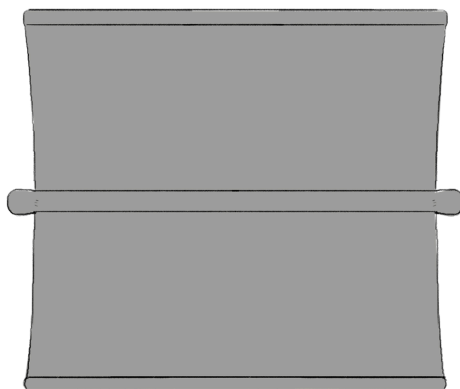
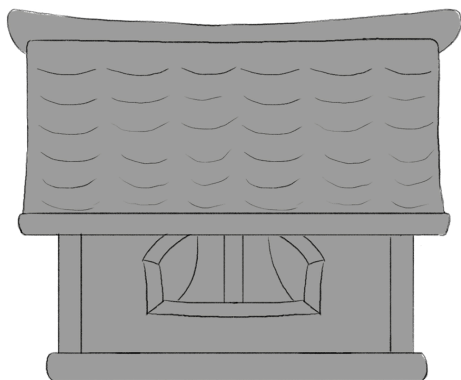
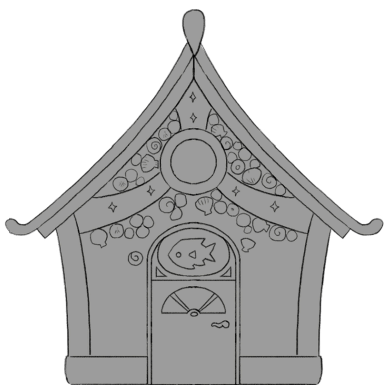
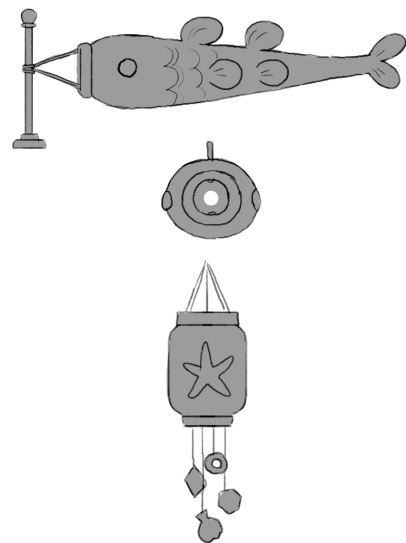

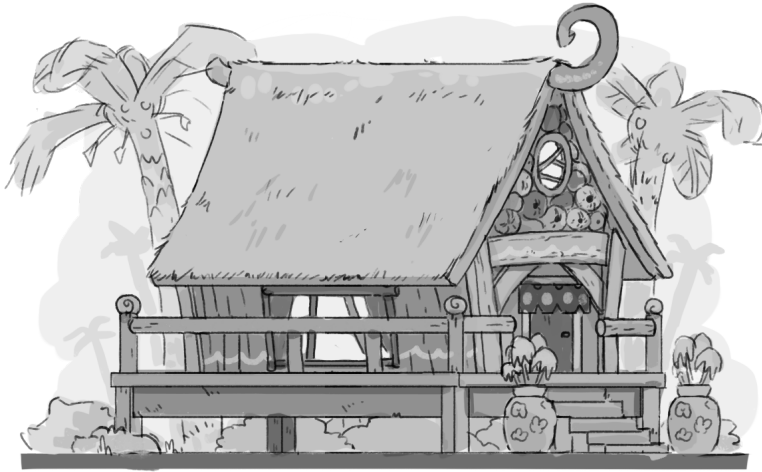

Koa's House

"I try to keep it clean, but it's difficult. It's always full of sand and dirt and soil, so I have to clean it often. It's my home, so I have to pay respect to it. And it, in return, gives me all this space to do whatever I want. I cook here and build things and sleep. Sometimes, at night, I think I see or hear a ghost, but It's always the seagulls, those little rascals, that want to sleep inside the house. So I let them in and they sleep here with me".

—Koa, brushing the beach.



THE ART OF SUMMER IN MARA

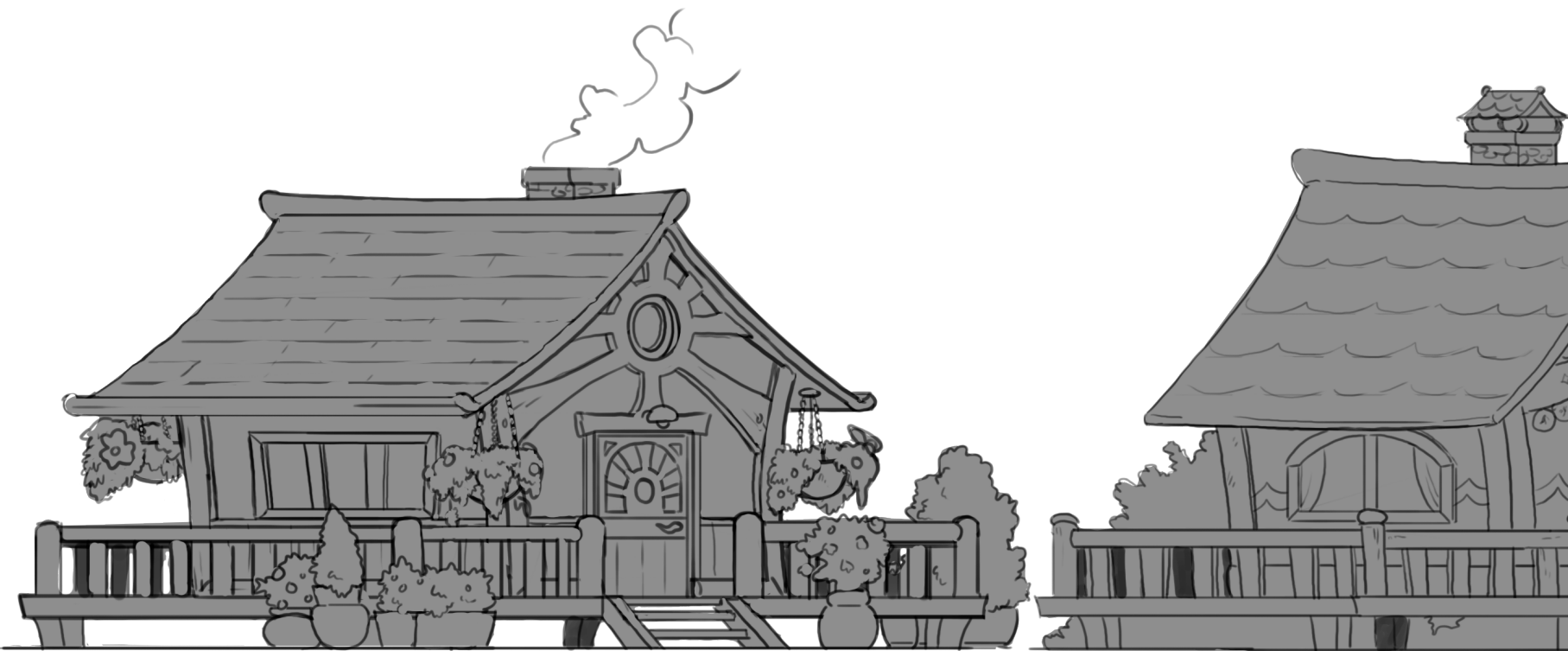

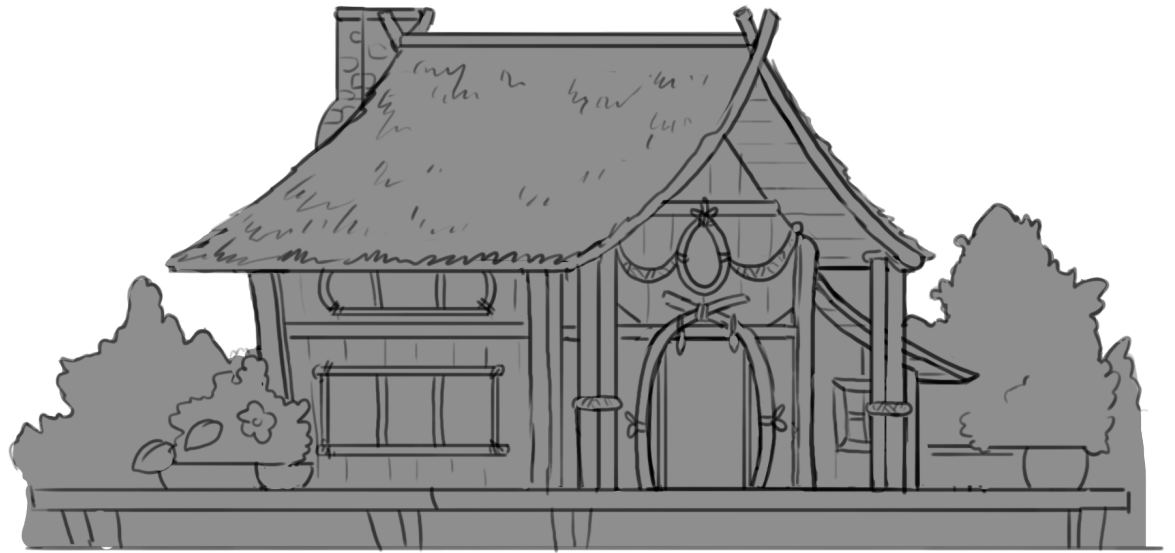

THE ART OF SUMMER IN MARA



Koa's house by daylight

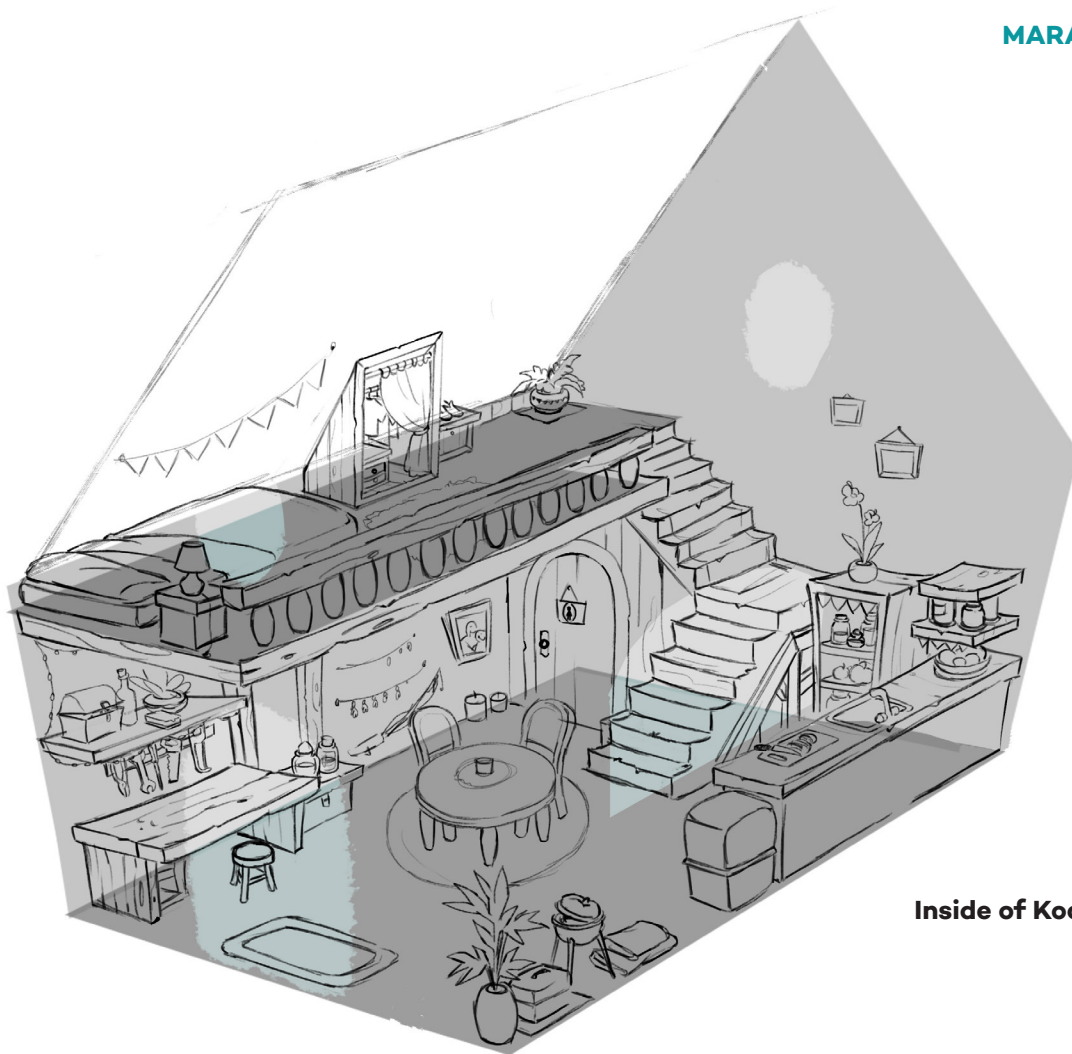

Inside of Koa's house

THE ART OF SUMMER IN MARA

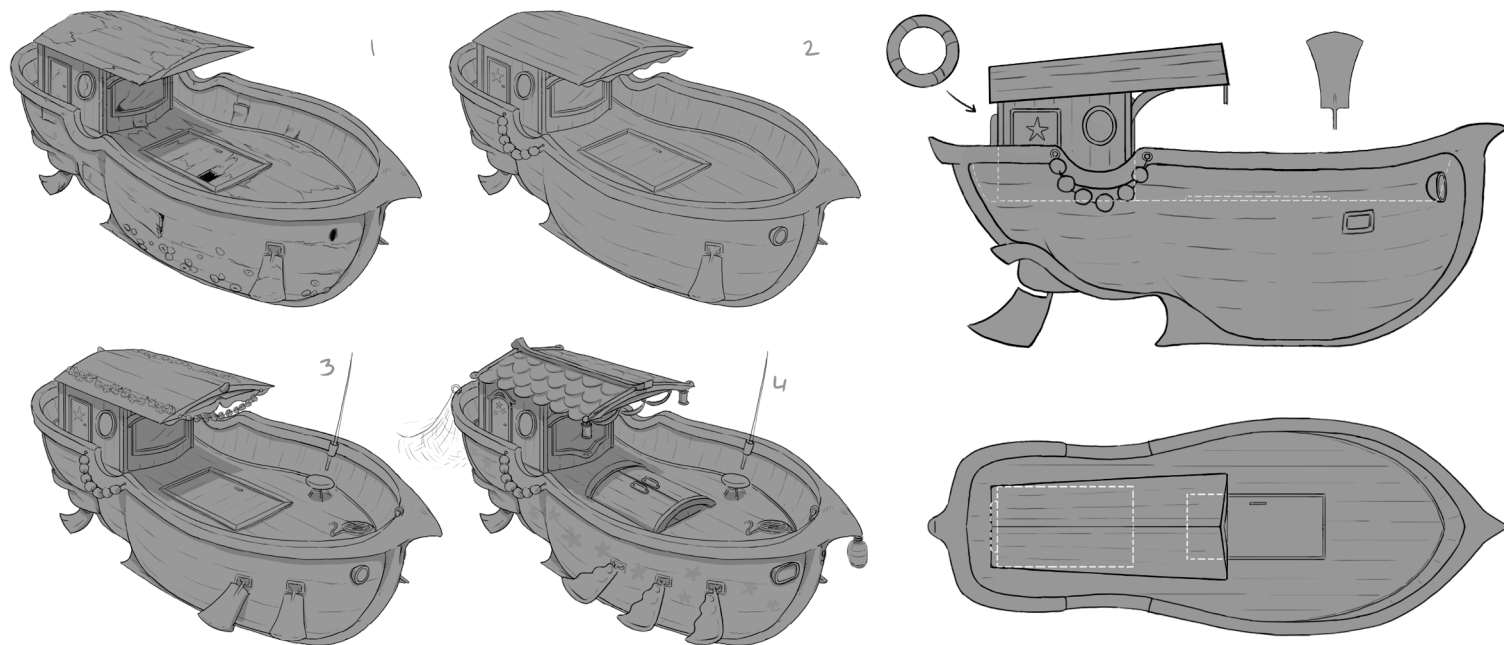

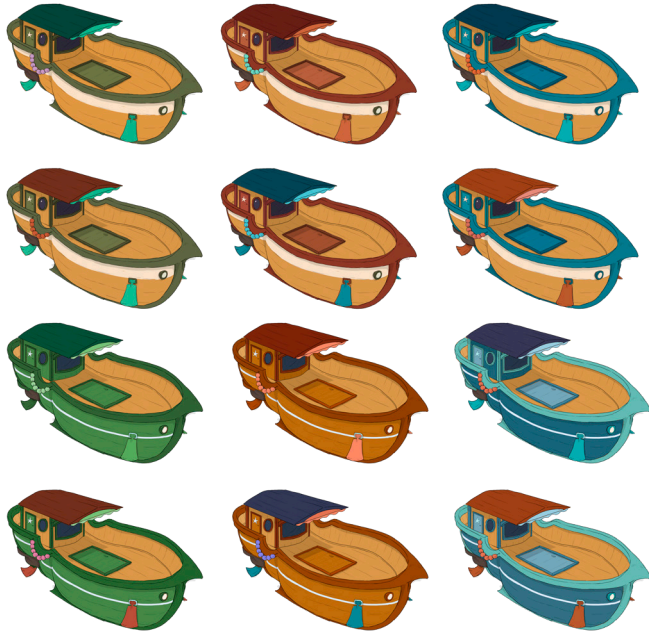

Yaya's boat

"I set my mind on this boat in the moment I saw it, in the Qälis shipyard. It was built by a big old qüido, very calm and relaxed. It was really expensive, so I had to ask for a loan at the bank .I won't pay it back, of course. That's nonsense. This is my boat now, and someday it will be Koa's".

—Haku, picking up the moorings.



Props & Icons



Qälis City Island

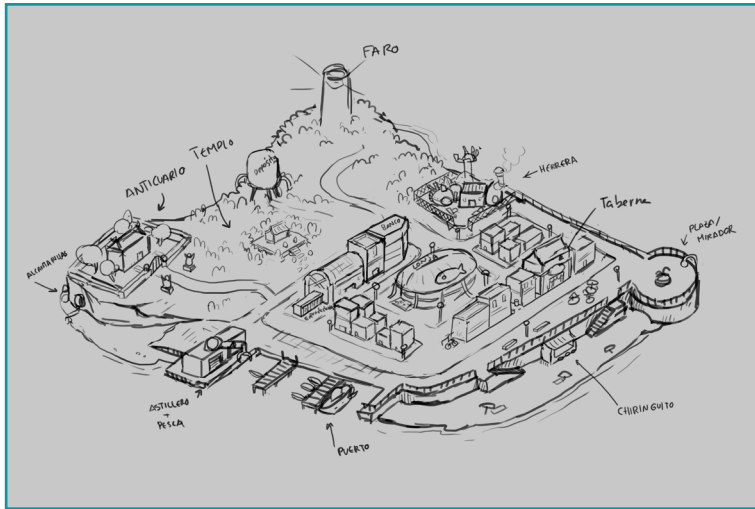

“Qälis has evolved since its inauguration, more than 300 years ago. Nowadays, the island is the center of Mara, full of life and color. The city brings hundreds of tourists every year, thanks to its unrivaled settings and beaches. The best shop in the whole city, Noho’s Shop, offers the opportunity to purchase a unique souvenir for a loved one”.

—Noho’s Mara Flyer



Bank

A Place to Keep

“A place where all the savings in Qälis are. You can cash a check here or get a mortgage, but the danger doesn’t lay there: be very careful of its banker. Edegan gossips like no other. He knows everything about our bank accounts, so he’s very aware of who bought what or who is broke. Take care, tourist, of this person”.

— Noho’s informative Flyer

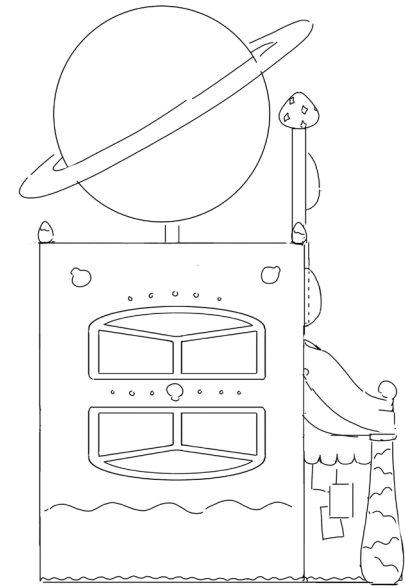
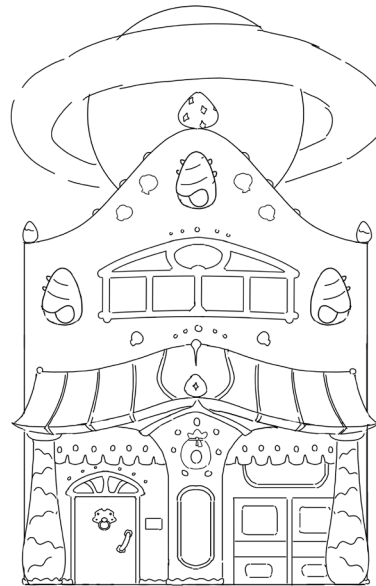



Lighthouse

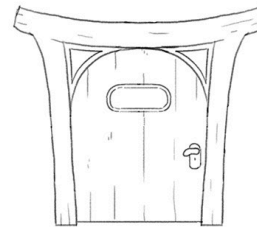
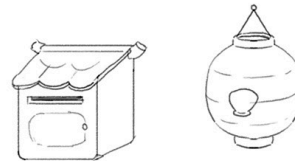
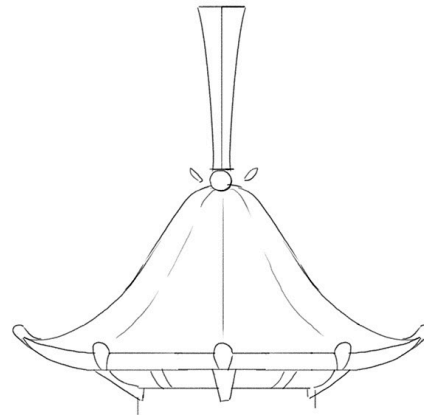

MARA · QÄLIS, CITY ISLAND

A Place to See

“The main attraction of the island is the lighthouse. But you can only see it from outside since it has its own inhabitant and she won’t let you visit it. Even though, don’t miss it! It’s very beautiful, a representation of what qüido architecture can accomplish”.

—Noho’s informative Flyer



Mansion

A Place to Stay Away

“We want to warn all tourists about this mansion: do not approach it. There’s an elder elit living there, nobody knows why, and he has very bad manners. We know the mansion is very beautiful and it has high artistic value, but it’s not worth the risk. You can suddenly find yourself putting up with swearing or something nasty, because, like we told you before, this elit is unpleasant”

—Noho’s informative Flyer





Noho's Shop

A Place to Be

“The best shop in Qälis. In this amazing place, you will find all kinds of memorabilia and merchandising from Mara, plus everything that a great fisherquido needs. Noho’s Shop is a must for every tourist in Mara!”

—Noho’s informative Flyer

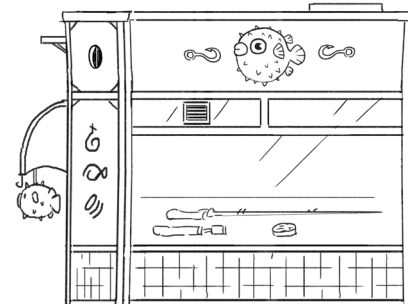
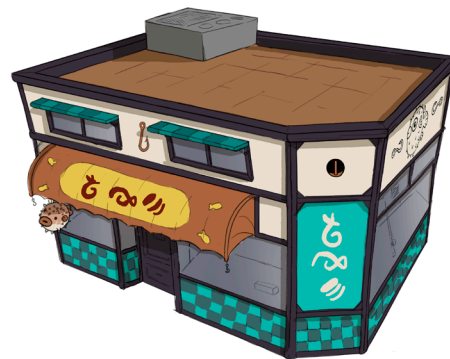
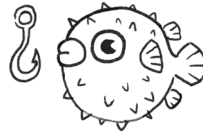



Restaurant

A Place to Avoid

“Don’t go near this so-called restaurant. Its food is awful and that cat-child waitress is somehow worse. You can eat some specialties from Ankora, but who wants that? We strongly recommend tourists to not expend a single coin in this place”.

—Noho’s informative Flyer



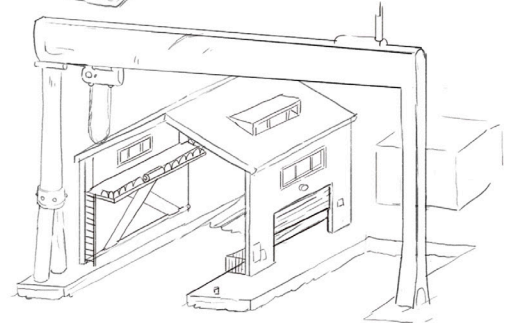
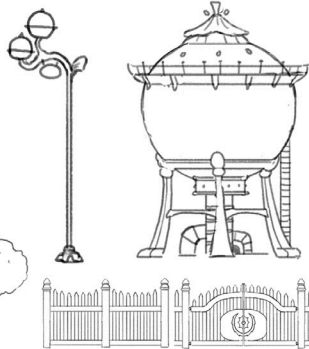
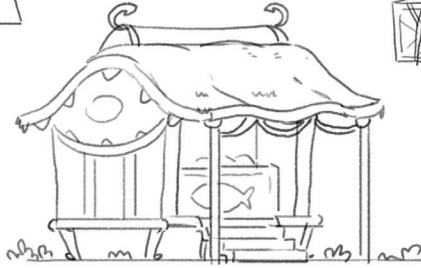
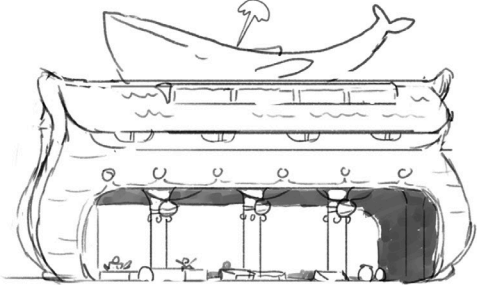
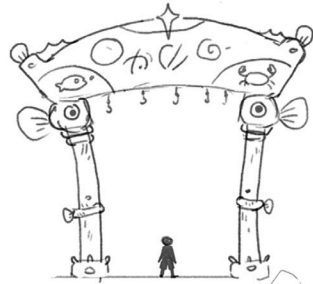
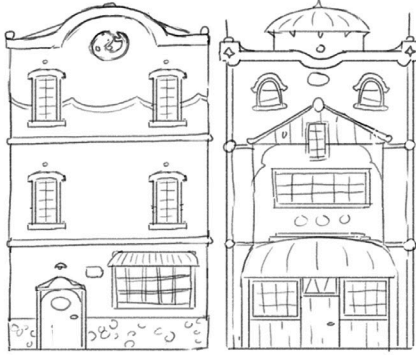

Buildings

“Architecture in Qälis is rather functional. These buildings are made with a special brick that keeps the heat outside and filters the air, so it’s always cozy inside”.

—Noho’s informative Flyer

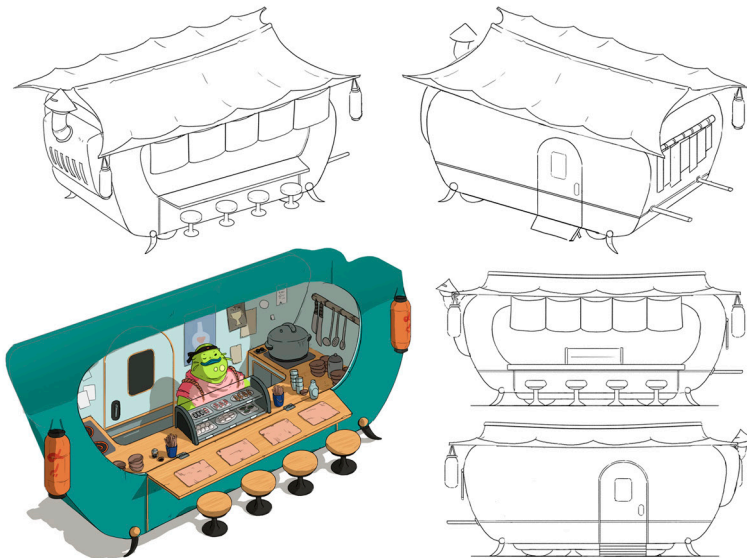

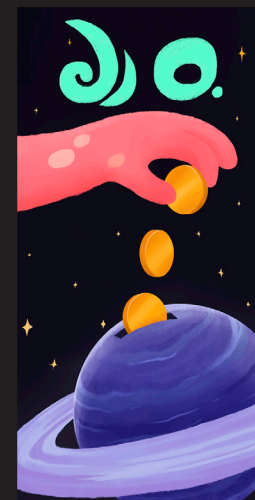
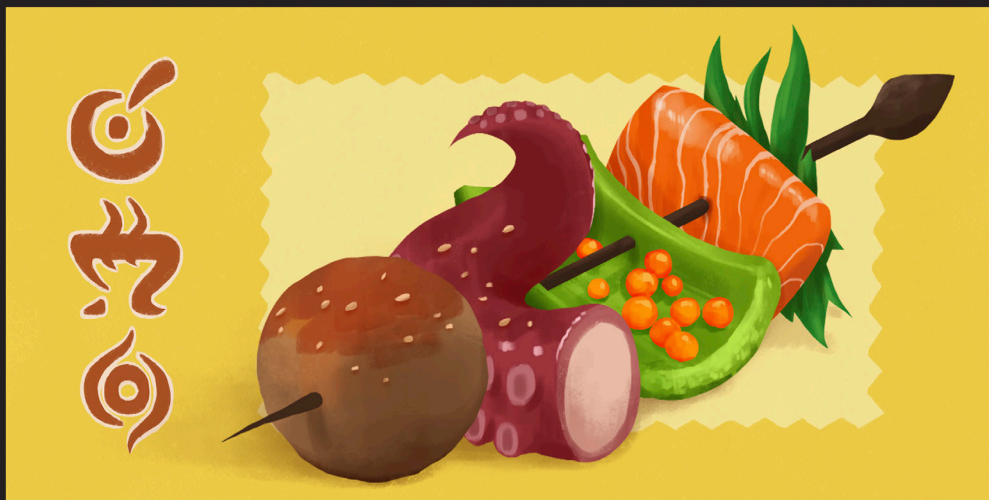

THE ART OF SUMMER IN MARA

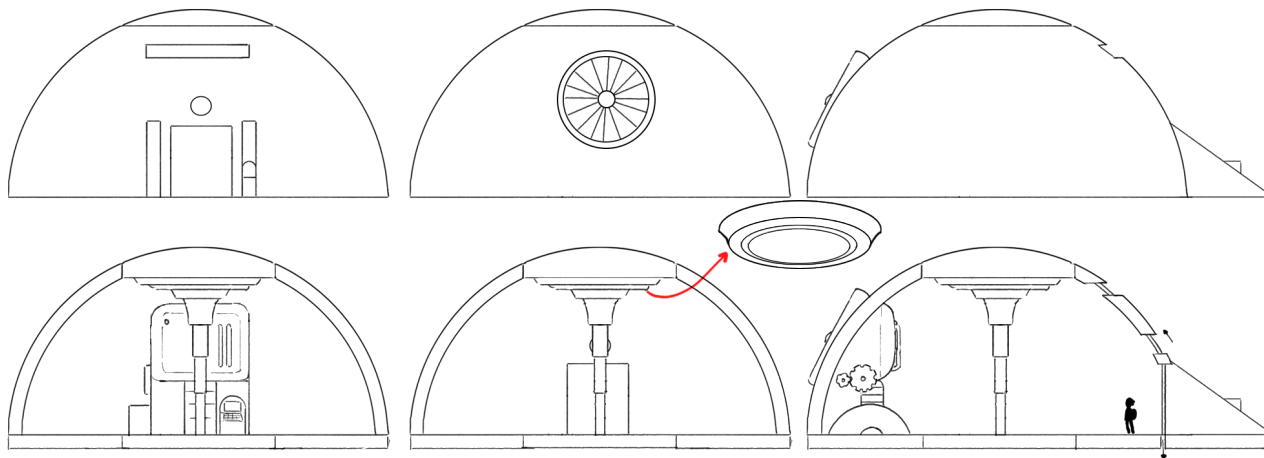

Open Ocean



Desert Island

“Oh, the desert island. Never been there, never will be. It’s an empty island with strange civilized bugs. They appear to make strange artifacts, so they have energy and can use machines. At least, it looks like they do it. But you never know...”

—Noho’s informative Flyer



Temple of Life

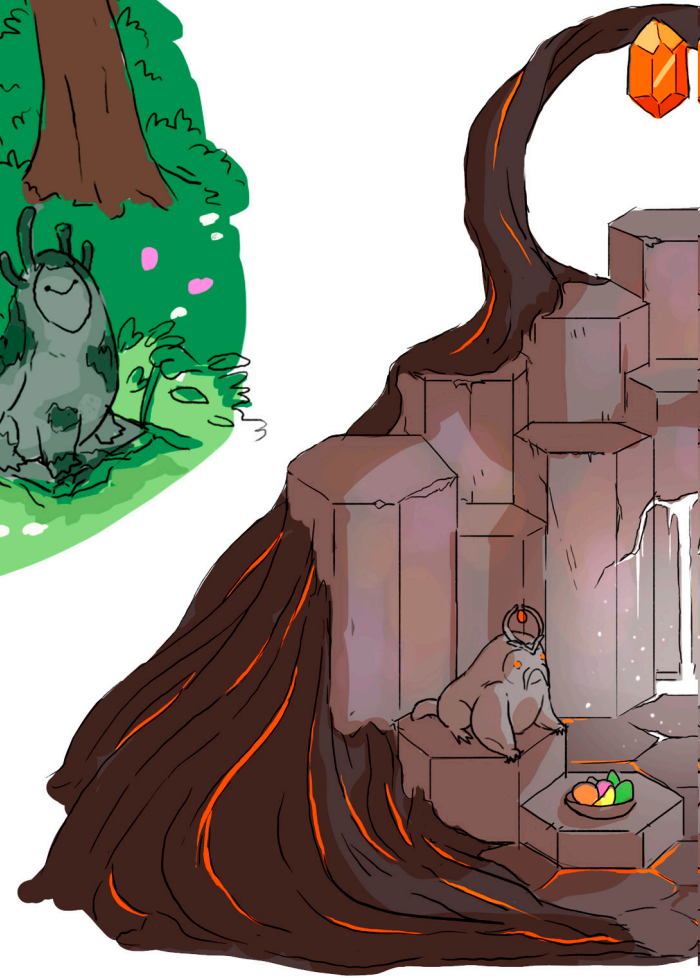

Temples of Mara



Temple of Fire



Temple of Water

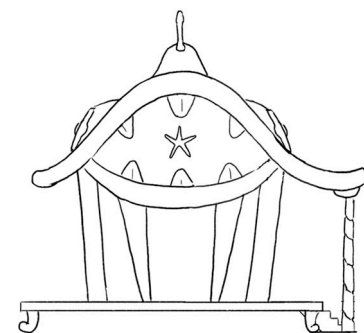
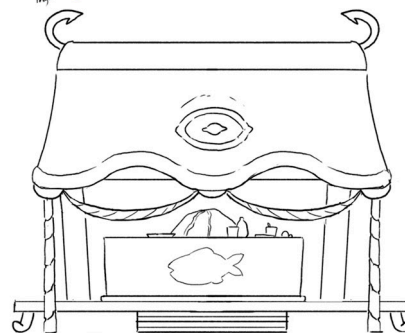
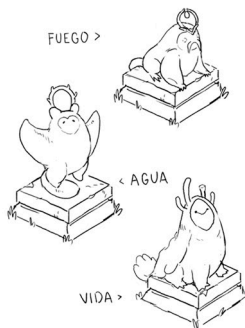
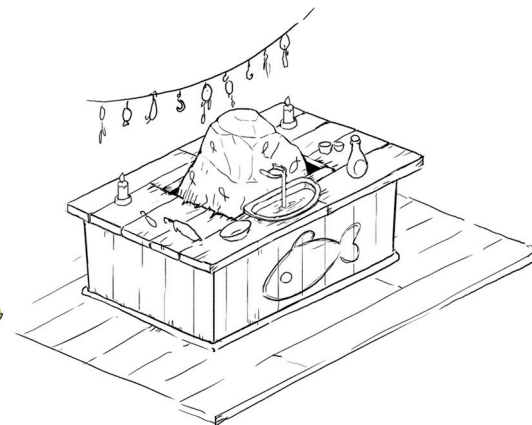



Frozen Colossus

“A tourist sailing through the ocean might think: “What a fearsomely impressive colossus!” But no need for fear, stranger! This... thing doesn’t move at all, frozen in time and space, it’s just another rarity in Mara”

—Noho’s informative Flyer

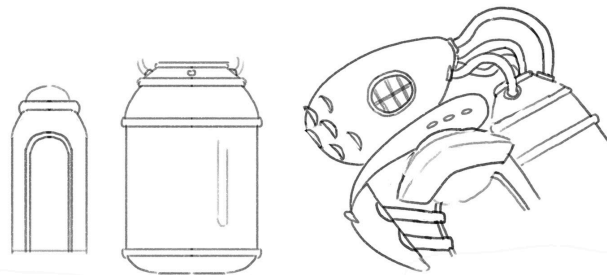



Boats

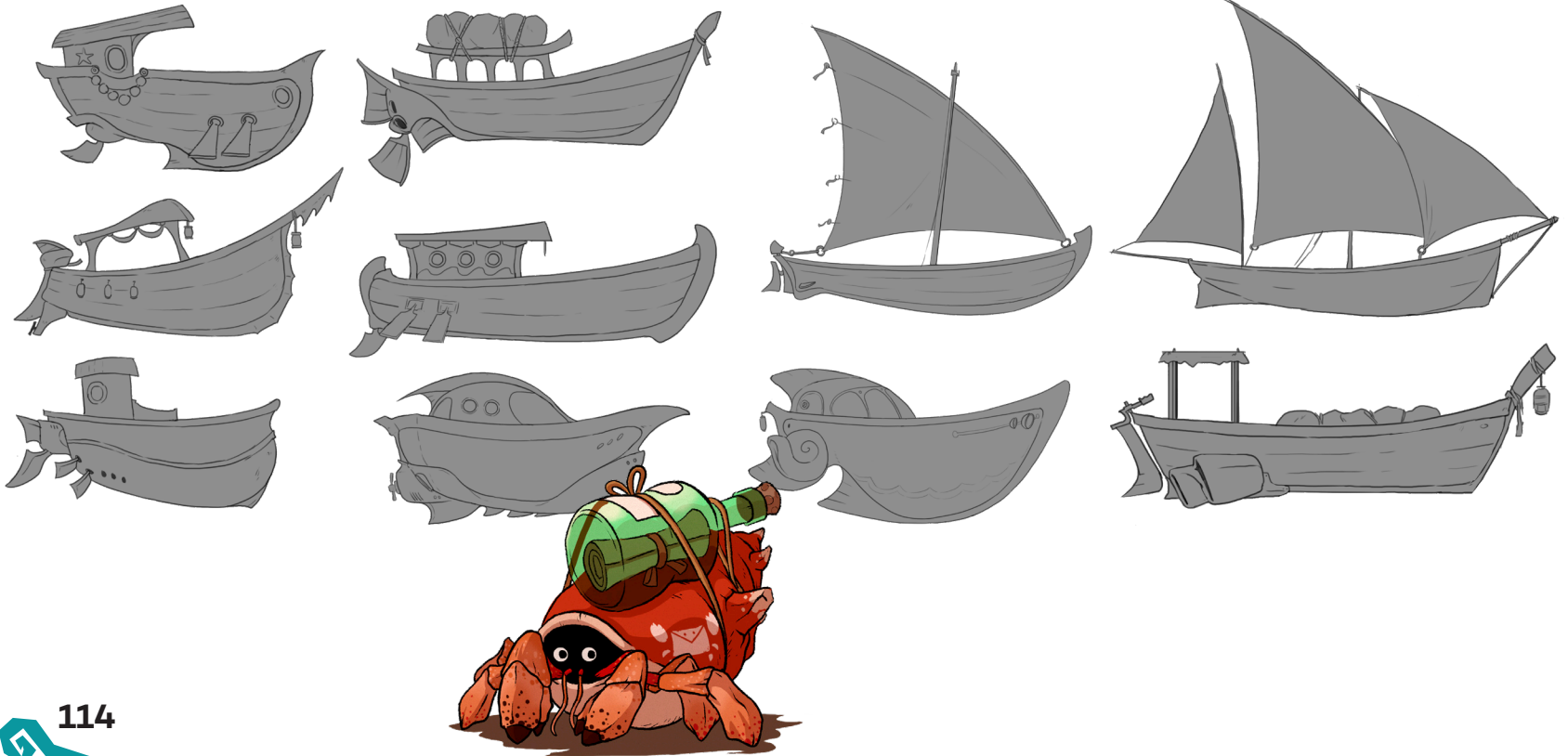

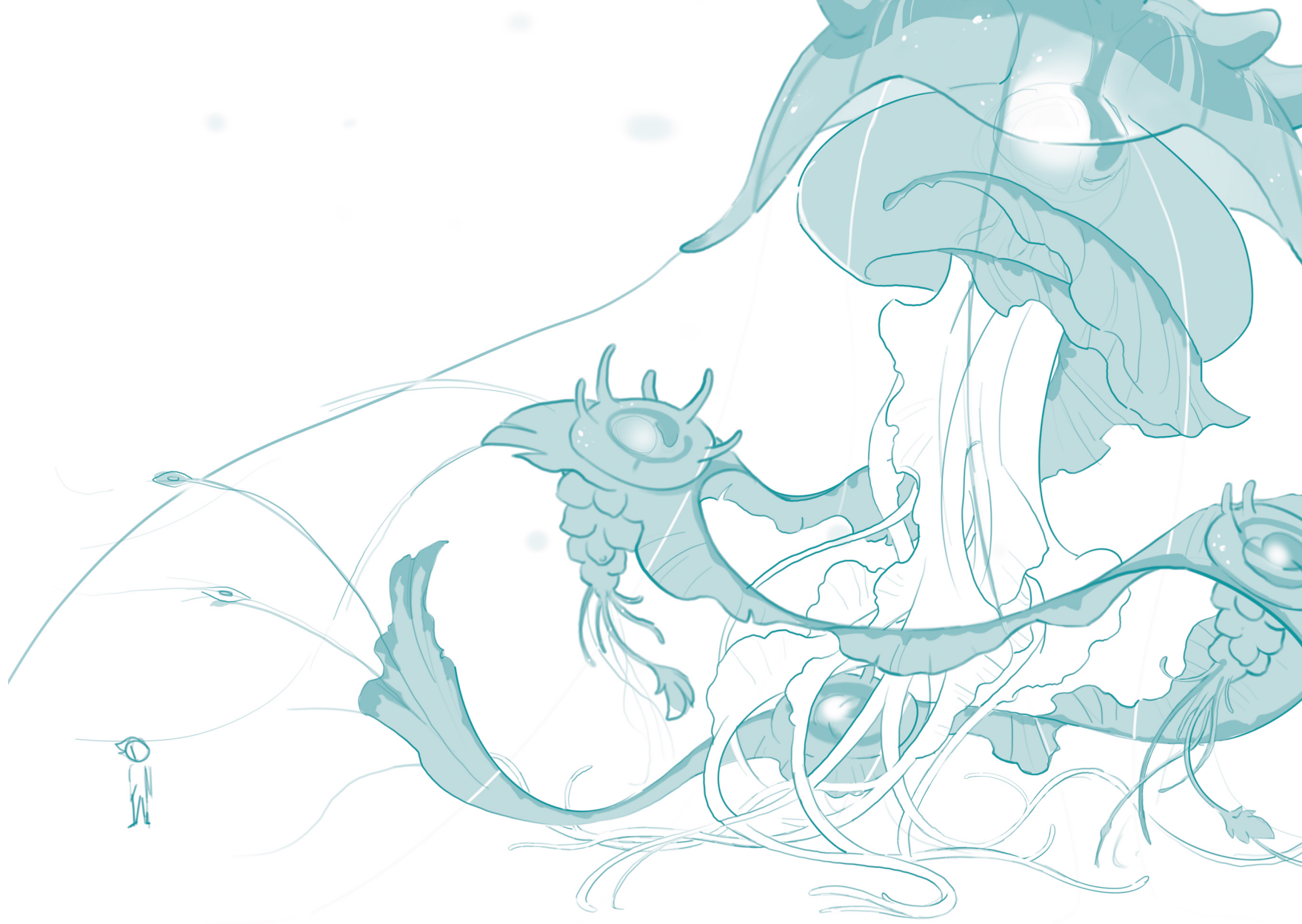



THE ART OF SUMMER IN MARA

...

Animation

CHAPTER IV





Opening











THE ART OF SUMMER IN MARA

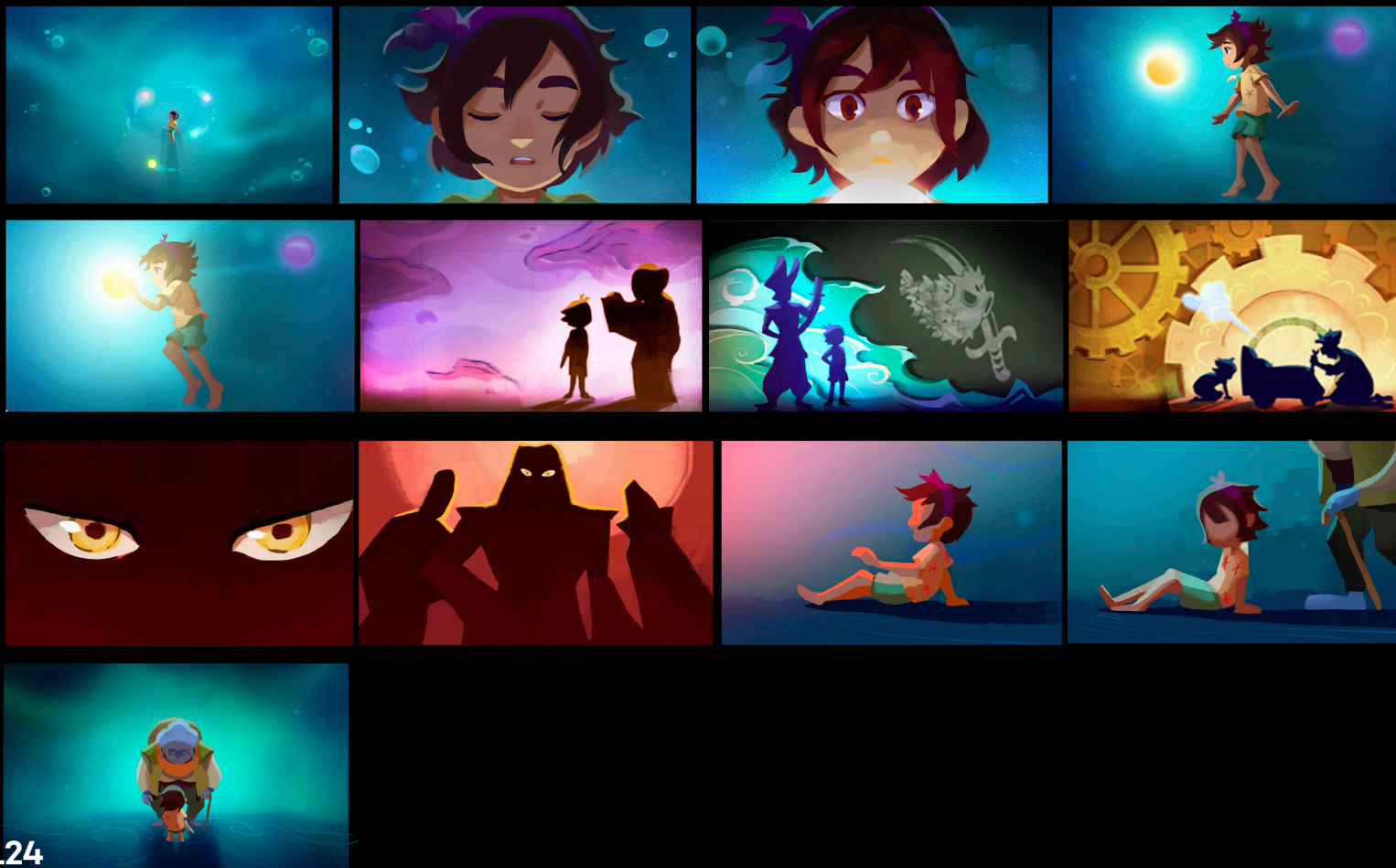

THE ART OF SUMMER IN MARA

Medus

126

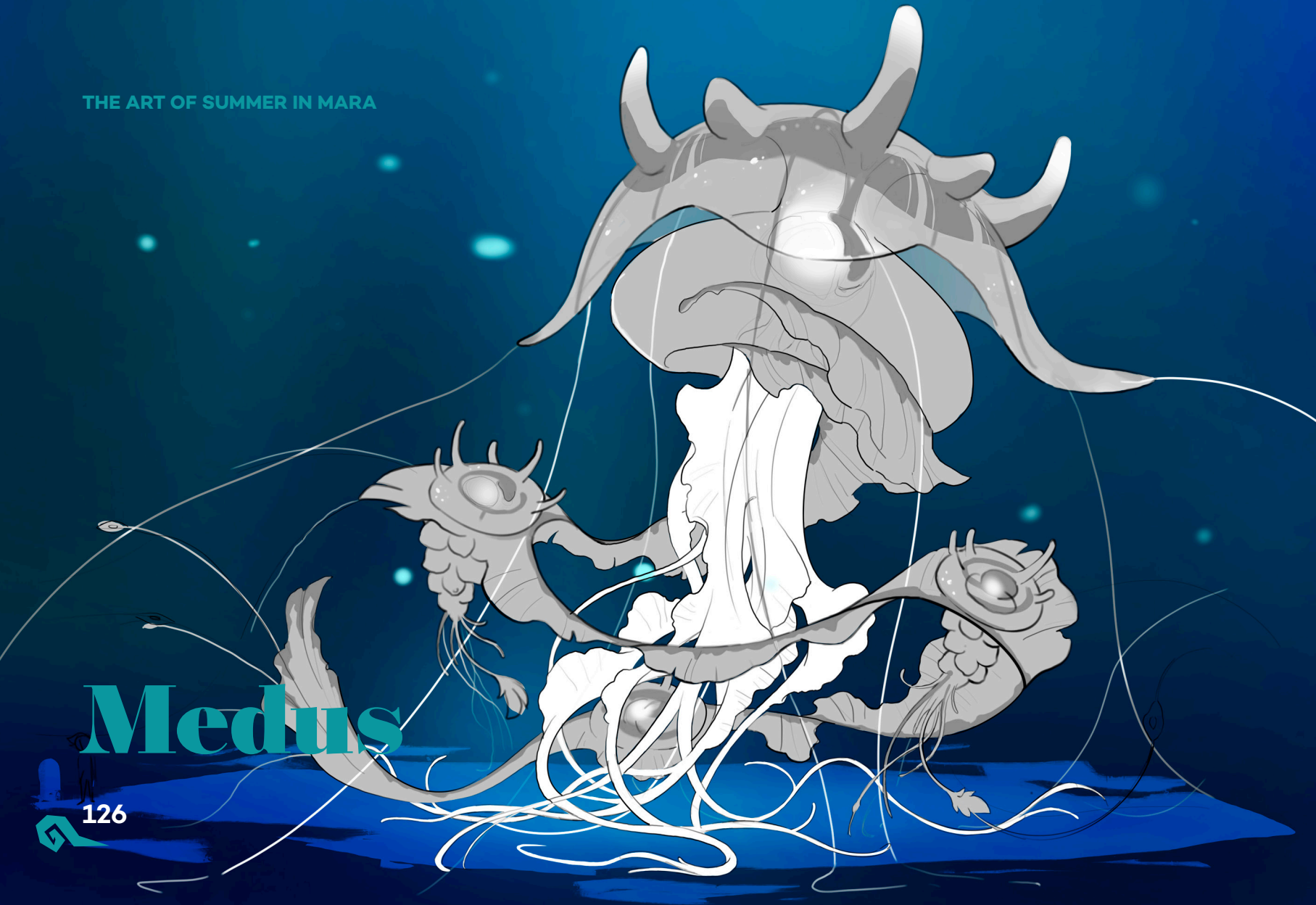

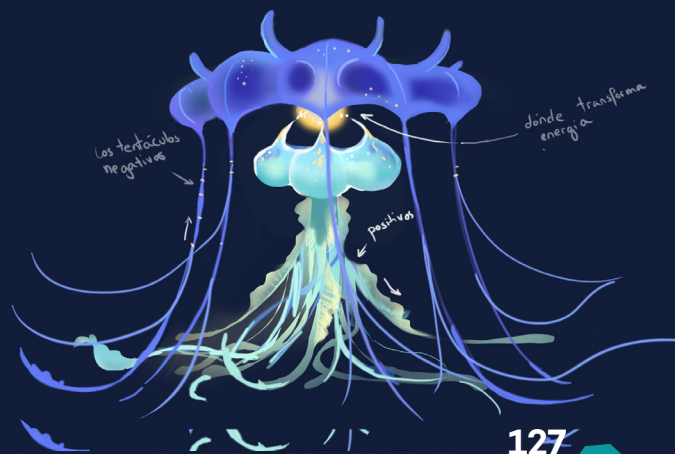
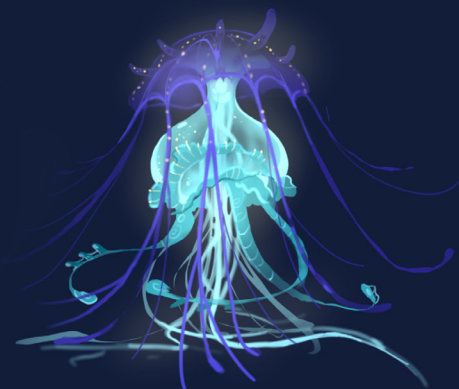

THE ART OF SUMMER IN MARA

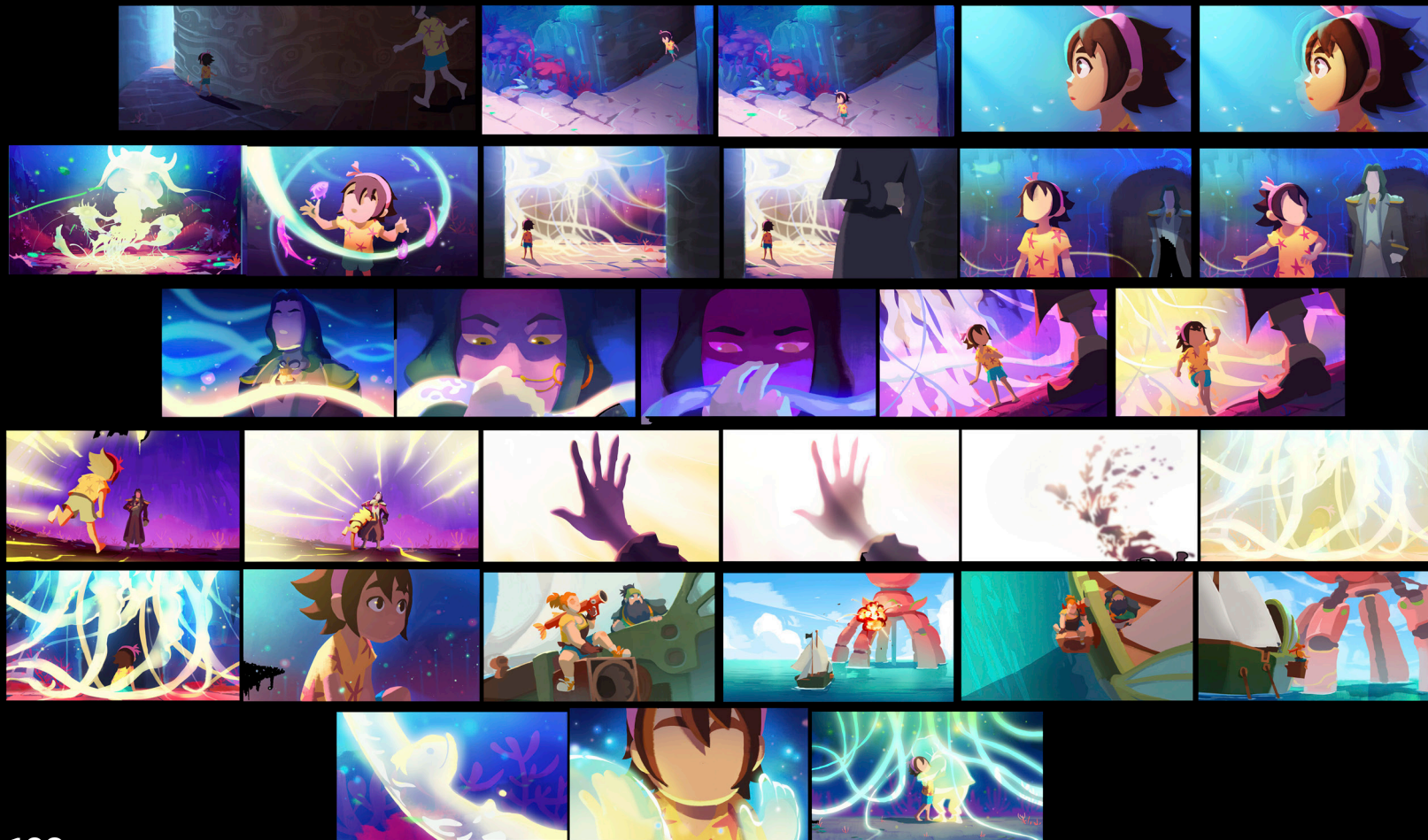

ENDING

Color Script







Cut scenes





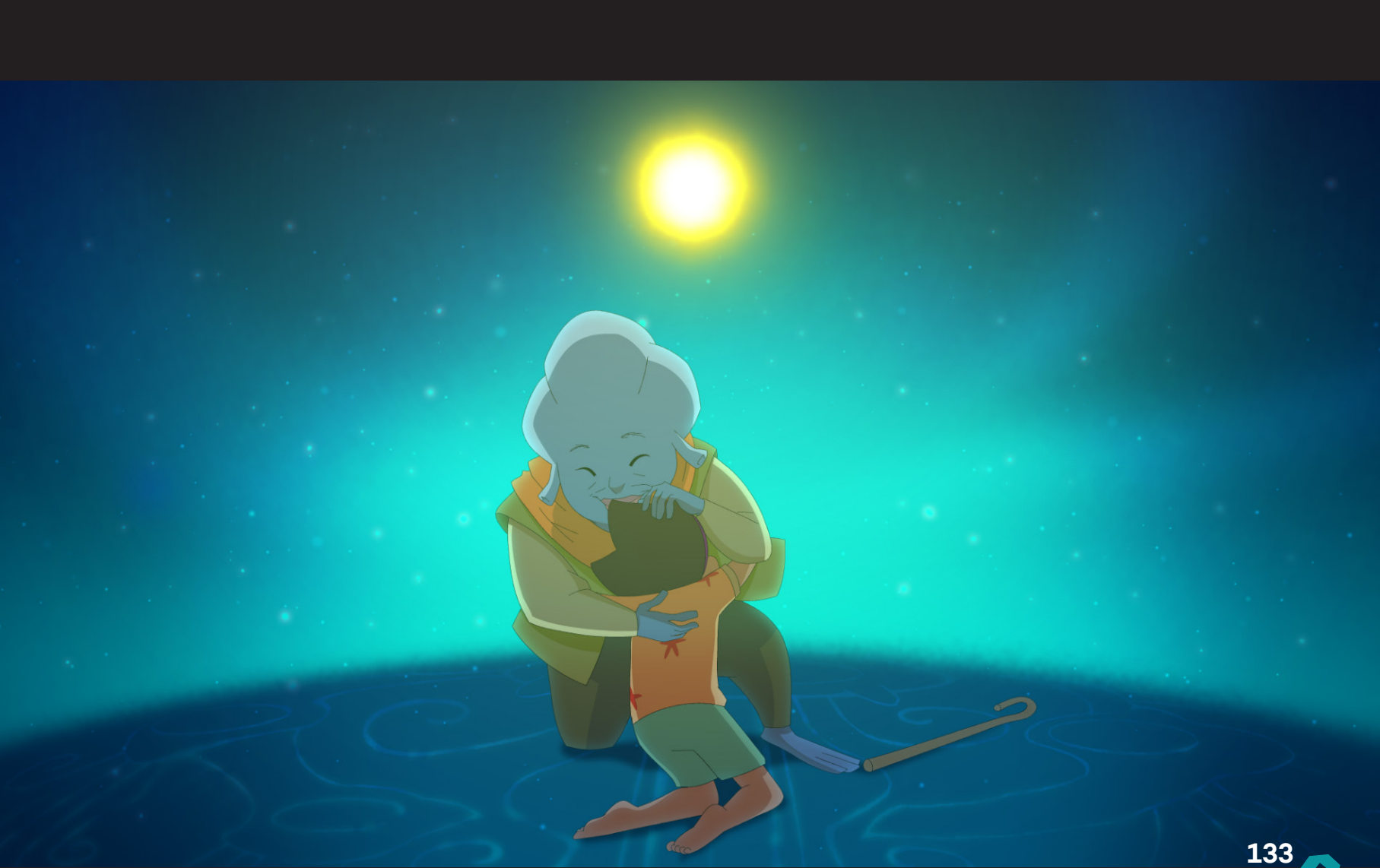





















THE ART OF SUMMER IN MARA

Ukulele

♩ = 190 C F G

7-7 7-8 10 10-7 3 2

Uk.

17 Am F

7-7 7-8 10 7 3-3 3-0

Uk.

5 C F G

3 7-7 7-8 10 10-7 3 2 3-2

Uk.

21 C Em

3

Uk.

9 Am F

0 7-7 7-8 10 7 3-3 3-0

Uk.

25 Am F

15 15 14 12 10 10 8 10 8

Uk.

13 C Em

0 3

Uk.

29 C Em

7 7 5 3 2

Uk.

33 Am F C

37 Em

Summer in Mara

Music by Adrián Berenguer

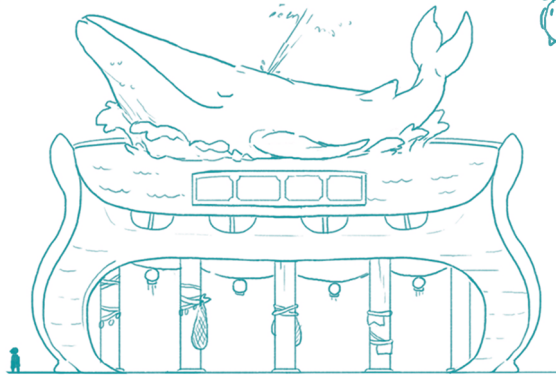
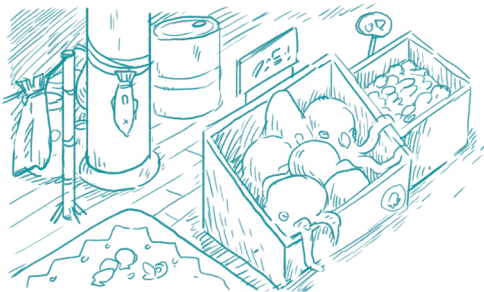
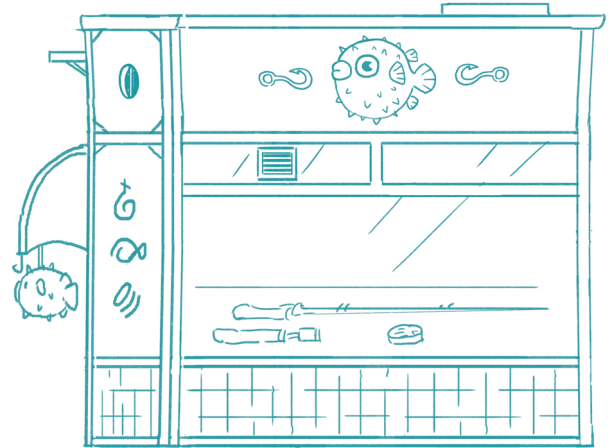
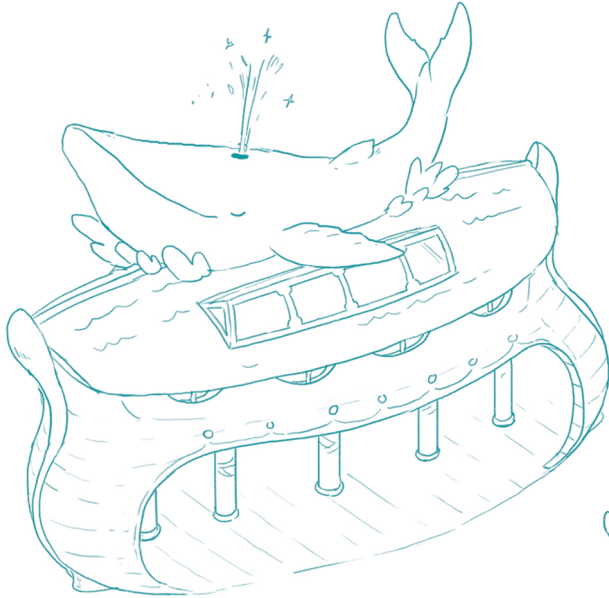
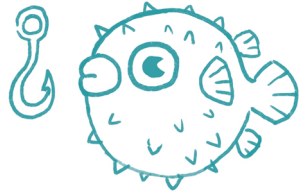

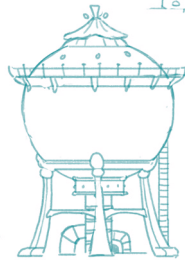
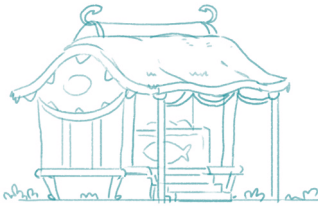
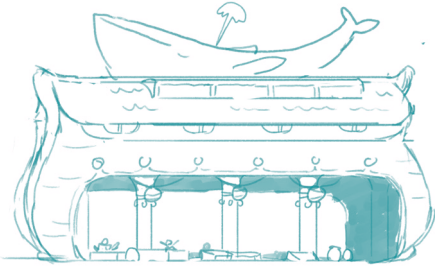
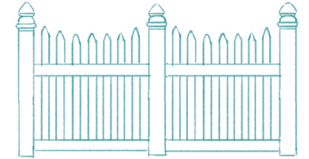
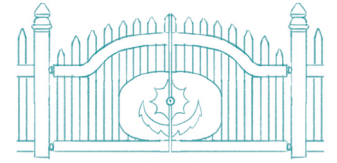
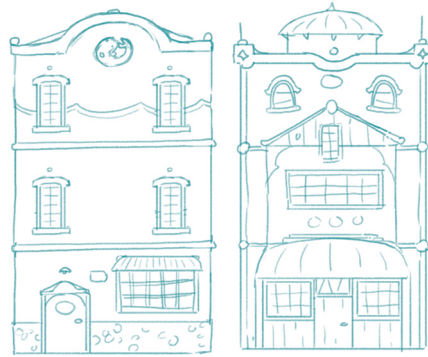

THE ART OF SUMMER IN MARA

...

Promotional

CHAPTER V



Photo Mode!



Koa



THE ART OF SUMMER IN MARA

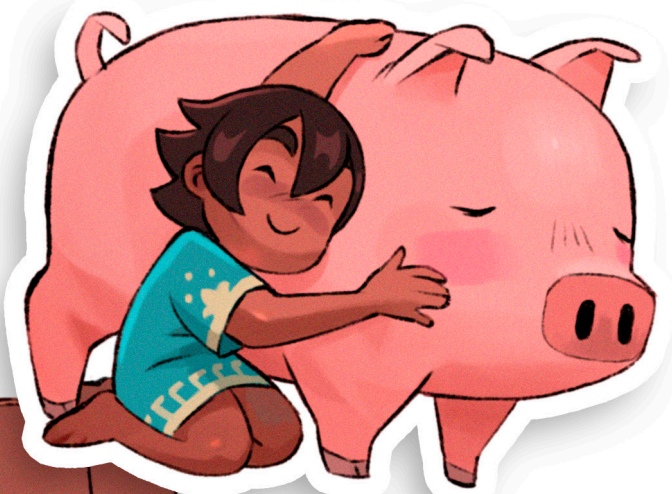

Stickers







Illustrations





PROMOTIONAL · ILLUSTRATIONS





Prints







Postcards





Artwork by **Caro**

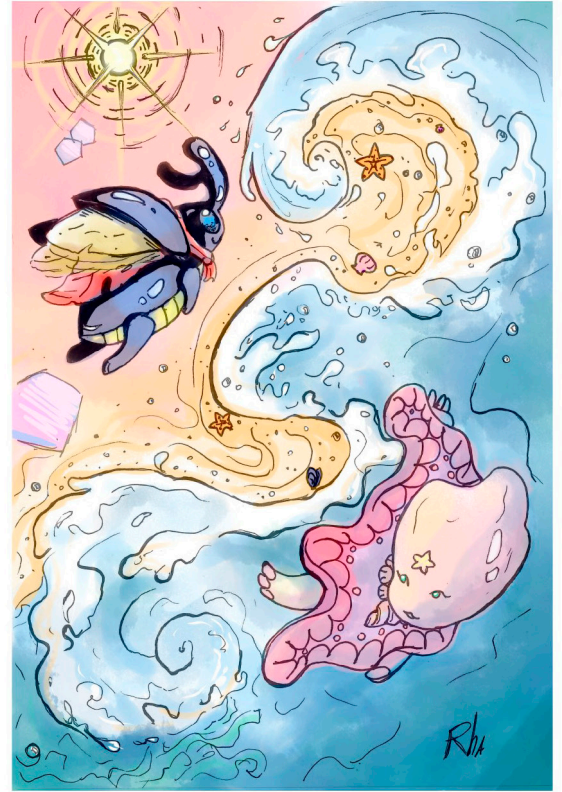

Artwork by **Paloma**



Artwork by **Fran**

Inktober



Artwork by **Miriam**



MAYO - AÑO 03

SUMMER IN MARA - ABE ATTORNEY - FINAL FANTASY X - THE DIVISION 2 - DREAMS: A LEGUE TALE - SHIKI KUMI

CTM

SUMMER IN MARA | UN VERANO INFINITO

41

CTM

CTM

WWW.GAMESTRIBUNE.COM

Un verano infinito

Summer in Mara

Games Tribune Magazine

For their May's cover issue, GTM asked us to work together and create something unique. Our artists worked hard to bring this colorful illustration to life and GTM added some outstanding visual effects to the production. The cover displayed some areas printed with 3D UV barnish that enhanced the art with a selective 3D gloss that powered the fresh and watery look of the artwork.





Game Cover

“Mara is in an endless summer. I like it that way. I saw the snow, and I saw the rain. I thought this was going to be harder, but with these people helping each other, I know Mara will fine. No matter what happens next. I will look out for Mara. And I know that Mara is looking our for me. Nothing can go wrong here. In this endless, infinite summer. Right, Napopo?”

—**Koa**, on the prow of her ship.



THE ART OF SUMMER IN MARA

...

Fan Art



CHAPTER VI

THE ART OF SUMMER
IN MARA

Artist:

Azoura



M



Artist:

**Marina Izquierdo
García**



THE ART OF SUMMER
IN MARA

Artist:

Sydney Adams



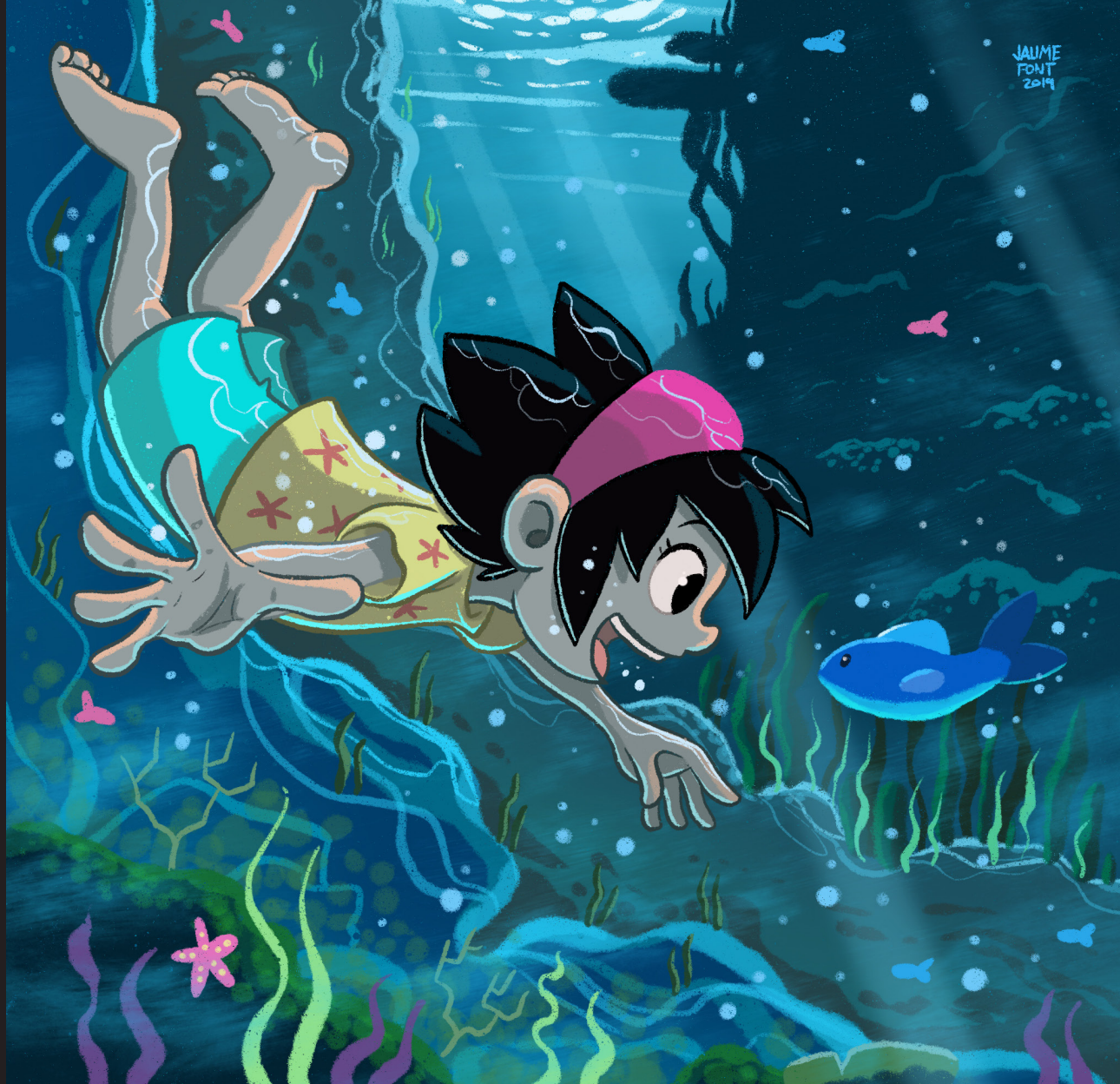

FAN ART

Artist:

Jaume Font Rosselló

THE ART OF SUMMER
IN MARA

Artist:

Yue Mizukirz



Artist:

María J.L. ►
(page 172)



Miriam

Vicente

Fran

CAROL WATCO

Lucas

THANK YOU

This book would not have been possible without the support of the backers who made donations to our Kickstarter campaign. This artbook is also your creation.

Paloma

Diego



CHIBIG

Abraham

Pablo

Rubén



GTM
— EDICIONES



9 788412 075984

PVP 24,99€

