

HP ProLiant DL385 Generation 2 Server User Guide



Part Number 411576-004
November 2007 (Fourth Edition)

© Copyright 2004, 2007 Hewlett-Packard Development Company, L.P.

The information contained herein is subject to change without notice. The only warranties for HP products and services are set forth in the express warranty statements accompanying such products and services. Nothing herein should be construed as constituting an additional warranty. HP shall not be liable for technical or editorial errors or omissions contained herein.

Microsoft, Windows, and Windows NT are U.S. registered trademarks of Microsoft Corporation. Windows Server 2003 is a trademark of Microsoft Corporation.

Audience assumptions

This document is for the person who installs, administers, and troubleshoots servers and storage systems. HP assumes you are qualified in the servicing of computer equipment and trained in recognizing hazards in products with hazardous energy levels.

Contents

| | |
|---|-----------|
| Component identification | 7 |
| Front panel components | 7 |
| Front panel LEDs and buttons | 8 |
| Systems Insight Display LEDs | 9 |
| Rear panel components | 10 |
| PCI expansion slot definitions | 10 |
| PCI riser board expansion slot definitions | 11 |
| Rear panel LEDs and buttons | 11 |
| System board | 12 |
| System board components (6-fan configuration) | 12 |
| System board components (12-fan configuration) | 13 |
| DIMM slots | 14 |
| System maintenance switch | 14 |
| NMI functionality | 15 |
| Systems Insight Display LEDs and internal health LED combinations | 15 |
| Device numbers | 17 |
| SAS and SATA hard drive LEDs | 17 |
| SAS and SATA hard drive LED combinations | 18 |
| PCI riser cage LED | 18 |
| Battery pack LEDs | 19 |
| Hot-plug fans (6-fan configuration) | 21 |
| Hot-plug fans (12-fan configuration) | 21 |
| Fan board components | 22 |
| Operations | 23 |
| Power up the server | 23 |
| Power down the server | 23 |
| Extend the server from the rack | 23 |
| Remove the access panel | 24 |
| Install the access panel | 25 |
| Remove the air baffle | 25 |
| Install the air baffle | 26 |
| Remove the PCI riser cage | 27 |
| Install the PCI riser cage | 27 |
| Access the product rear panel | 29 |
| Cable management arm with left-hand swing | 29 |
| Cable management arm with right-hand swing | 29 |
| Hot-plug fan operation | 30 |
| Setup | 31 |
| Optional installation services | 31 |
| Rack planning resources | 31 |
| Optimum environment | 32 |
| Space and airflow requirements | 32 |
| Temperature requirements | 32 |
| Power requirements | 33 |
| Electrical grounding requirements | 33 |

| | |
|---|-----------|
| Rack warnings | 34 |
| Identifying the contents of the server shipping carton..... | 34 |
| Installing hardware options..... | 35 |
| Installing the server into the rack..... | 35 |
| Powering up and configuring the server | 37 |
| Installing the operating system..... | 37 |
| Registering the server..... | 38 |
| Hardware options installation..... | 39 |
| Introduction | 39 |
| Processor option..... | 39 |
| Memory options | 46 |
| Advanced ECC memory | 46 |
| DIMM installation guidelines | 46 |
| Installing DIMMs | 47 |
| Hot-plug SAS hard drive options | 47 |
| Installing a hot-plug SAS hard drive | 48 |
| Removing a hot-plug SAS hard drive..... | 49 |
| Media drive option..... | 50 |
| Redundant hot-plug AC power supply option | 50 |
| DC power supply option | 51 |
| Expansion board options..... | 54 |
| Installing an expansion board (slot 2)..... | 54 |
| Removing an expansion slot cover (slot 3, 4, or 5)..... | 54 |
| Installing an expansion board (slot 3, 4, or 5)..... | 55 |
| PCI riser board option..... | 56 |
| Cabling | 58 |
| SAS hard drive cabling..... | 58 |
| PCI SAS cabling to an HP Smart Array P400i Controller..... | 58 |
| PCI SAS cabling to an optional expansion board controller | 58 |
| Fan board cabling..... | 59 |
| Battery cabling for BBWC | 59 |
| Systems Insight Display cabling | 60 |
| Hard drive backplane power cabling..... | 60 |
| Media drive bay cabling..... | 61 |
| PCIe x16 riser board power cabling..... | 61 |
| Configuration and utilities | 62 |
| Configuration tools | 62 |
| SmartStart software..... | 62 |
| HP ROM-Based Setup Utility..... | 63 |
| Array Configuration Utility | 64 |
| Option ROM Configuration for Arrays | 65 |
| HP ProLiant Essentials Rapid Deployment Pack | 65 |
| Re-entering the server serial number and product ID | 65 |
| Management tools..... | 66 |
| Automatic Server Recovery | 66 |
| ROMPaq utility..... | 66 |
| System Online ROM flash component utility | 66 |
| Integrated Lights-Out 2 technology..... | 67 |
| Erase Utility | 67 |
| StorageWorks library and tape tools..... | 67 |
| HP Systems Insight Manager | 68 |

| | |
|---|-----------|
| Management Agents | 68 |
| Redundant ROM support | 68 |
| USB support | 69 |
| Diagnostic tools | 70 |
| HP Insight Diagnostics | 70 |
| HP Insight Diagnostics survey functionality | 70 |
| Integrated Management Log | 71 |
| Array Diagnostic Utility | 71 |
| Remote support and analysis tools | 71 |
| HP Instant Support Enterprise Edition | 71 |
| Web-Based Enterprise Service | 71 |
| Open Services Event Manager | 72 |
| Keeping the system current | 72 |
| Drivers | 72 |
| ProLiant Support Packs | 72 |
| Operating system version support | 72 |
| Change control and proactive notification | 72 |
| Care Pack | 73 |
| Troubleshooting | 74 |
| Troubleshooting resources | 74 |
| Pre-diagnostic steps | 74 |
| Important safety information | 74 |
| Symptom information | 76 |
| Prepare the server for diagnosis | 77 |
| Loose connections | 77 |
| Service notifications | 78 |
| Troubleshooting flowcharts | 78 |
| Start diagnosis flowchart | 78 |
| General diagnosis flowchart | 79 |
| Server power-on problems flowchart | 81 |
| POST problems flowchart | 84 |
| OS boot problems flowchart | 85 |
| Server fault indications flowchart | 87 |
| POST error messages and beep codes | 89 |
| Battery replacement | 90 |
| Regulatory compliance notices | 91 |
| Federal Communications Commission notice | 91 |
| FCC rating label | 91 |
| Class A equipment | 91 |
| Class B equipment | 91 |
| Declaration of conformity for products marked with the FCC logo, United States only | 92 |
| Modifications | 92 |
| Cables | 92 |
| Canadian notice (Avis Canadien) | 92 |
| European Union regulatory notice | 93 |
| Disposal of waste equipment by users in private households in the European Union | 93 |
| Japanese notice | 94 |
| BSMI notice | 94 |
| Korean notice | 94 |
| Laser compliance | 95 |
| Battery replacement notice | 95 |

| | |
|---|------------|
| Taiwan battery recycling notice | 95 |
| Power cord statement for Japan..... | 96 |
| Electrostatic discharge | 97 |
| Preventing electrostatic discharge | 97 |
| Grounding methods to prevent electrostatic discharge..... | 97 |
| Specifications | 98 |
| Environmental specifications | 98 |
| Server specifications | 98 |
| Technical support..... | 100 |
| Before you contact HP..... | 100 |
| HP contact information | 100 |
| Customer Self Repair | 100 |
| Acronyms and abbreviations..... | 108 |
| Index..... | 112 |

Component identification

Front panel components

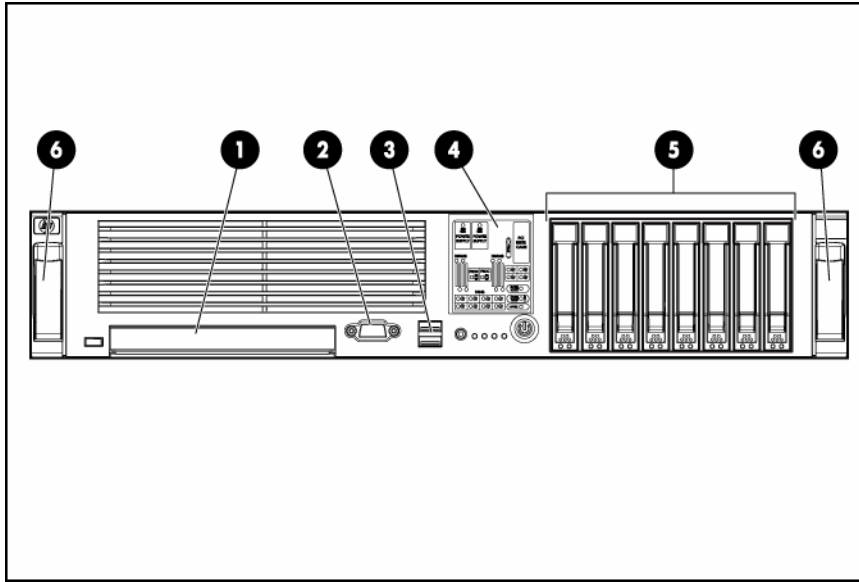

| Item | Description |
|------|---|
| 1 | Media drive bay (IDE/diskette multibay) |
| 2 | Video connector |
| 3 | USB connectors (2) |
| 4 | Systems Insight Display |
| 5 | Hard drive bays |
| 6 | Quick release levers (2) |

Front panel LEDs and buttons

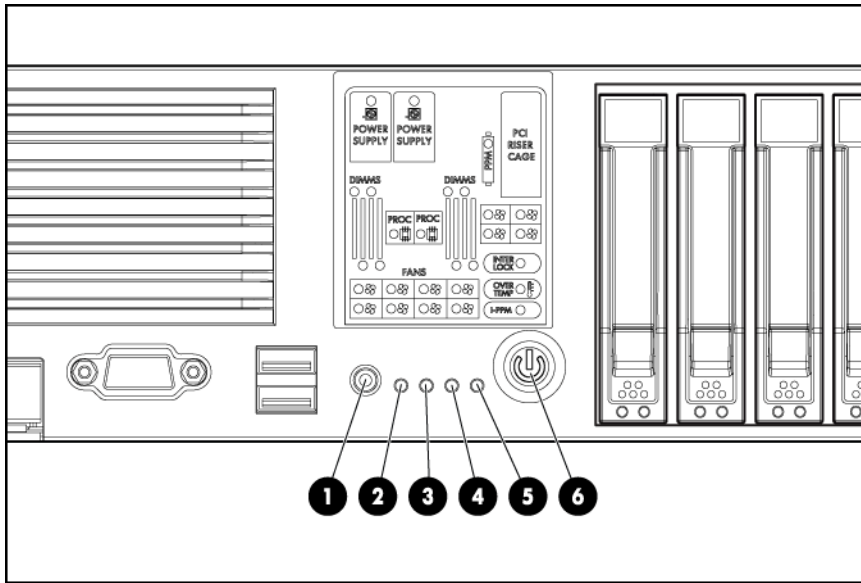

| Item | Description | Status |
|------|--|---|
| 1 | UID LED button | Blue = Activated Flashing = System being remotely managed Off = Deactivated |
| 2 | Internal health LED | Green = Normal Amber = System degraded. To identify component in degraded state, refer to Systems Insight Display LEDs. Red = System critical. To identify component in critical state, refer to Systems Insight Display LEDs. |
| 3 | External health LED (power supply) | Green = Normal Amber = Power redundancy failure. To identify component in degraded state, refer to Systems Insight Display LEDs. Red = Critical power supply failure. To identify component in critical state, refer to Systems Insight Display LEDs. |
| 4 | NIC 1 link/activity LED | Green = Network link Flashing = Network link and activity Off = No link to network. If power is off, view the rear panel RJ-45 LEDs for status. |
| 5 | NIC 2 link/activity LED | Green = Network link Flashing = Network link and activity Off = No link to network. If power is off, view the rear panel RJ-45 LEDs for status. |
| 6 | Power On/Standby button/system power LED | Green = System on Amber = System shut down, but power still applied Off = Power cord not attached or power supply failure |

Systems Insight Display LEDs

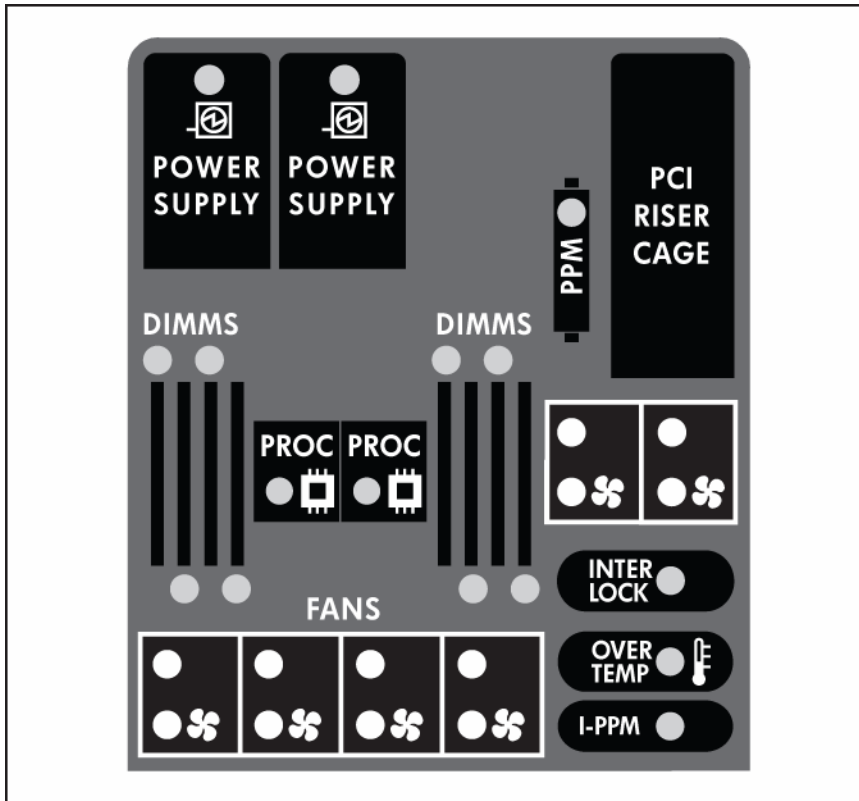

| |
|----------------|
| Status |
| Amber= Failure |
| Off = Normal |



IMPORTANT: If more than one DIMM slot LED is illuminated, further troubleshooting is required. Test each bank of DIMMs by removing all other DIMMs. Isolate the failed DIMM by replacing each DIMM in a bank with a known working DIMM.

NOTE: The HP Systems Insight Display LEDs represent the system board layout.

Rear panel components

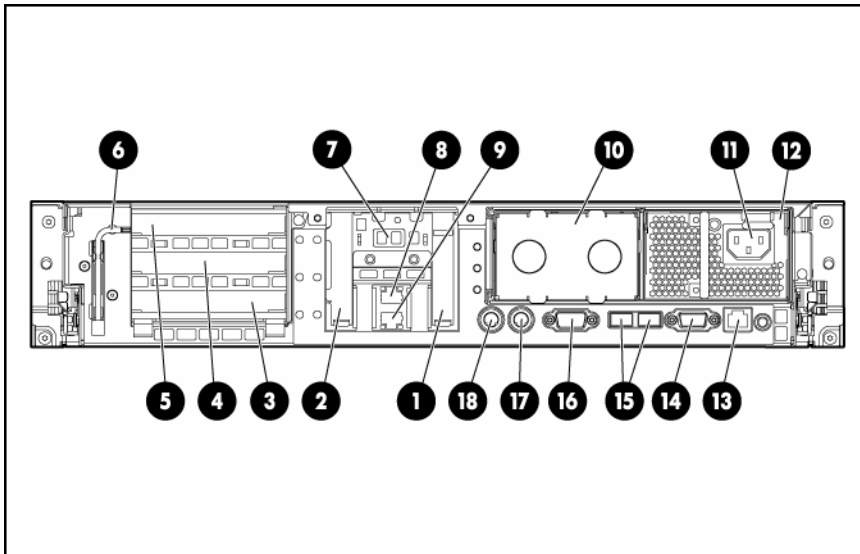

| Item | Description | Color |
|------|--------------------------------|--------|
| 1 | Expansion slot 1 | — |
| 2 | Expansion slot 2 | — |
| 3 | Expansion slot 3 | — |
| 4 | Expansion slot 4 | — |
| 5 | Expansion slot 5 | — |
| 6 | T-10/T-15 Torx screwdriver | — |
| 7 | External option blank | — |
| 8 | NIC 2 connector | — |
| 9 | NIC 1 connector | — |
| 10 | Power supply bay 2 | — |
| 11 | Power cord connector | Black |
| 12 | Power supply bay 1 (populated) | — |
| 13 | iLO 2 connector | — |
| 14 | Video connector | Blue |
| 15 | USB connectors (2) | Black |
| 16 | Serial connector | — |
| 17 | Mouse connector | Green |
| 18 | Keyboard connector | Purple |

PCI expansion slot definitions

| Slot | Type and speed |
|------|----------------|
| 1 | PCIe x8 |
| 2 | PCIe x8 |

All slots are non-hot-plug.

PCI riser board expansion slot definitions

| Slot | PCIe riser board | Mixed PCIe/PCI-X riser board | PCIe x16 riser board |
|------|------------------|------------------------------|----------------------|
| 5 | x8 | 64-bit/133-MHz | — |
| 4 | x8 | 64-bit/133-MHz | x16 |
| 3 | x4 | x8 | x4 |

All slots are non-hot-plug.

Rear panel LEDs and buttons

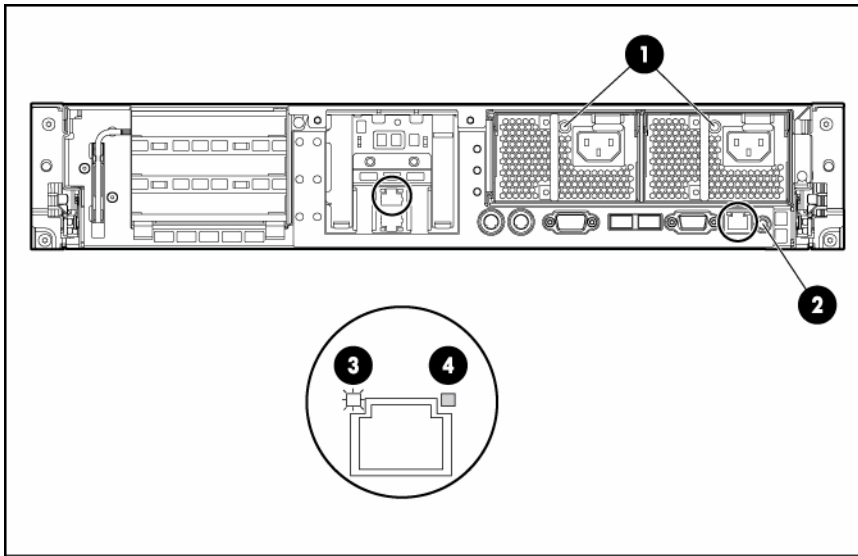

| Item | Description | Status |
|------|------------------------|--|
| 1 | Power supply LED | Green = Normal Off = System is off or power supply has failed |
| 2 | UID LED button | Blue = Activated Flashing = System being remotely managed Off = Deactivated |
| 3 | NIC/iLO 2 activity LED | Green = Network activity Flashing = Network activity Off = No network activity |
| 4 | NIC/iLO 2 link LED | Green = Network link Off = No network link |

System board

System board components (6-fan configuration)

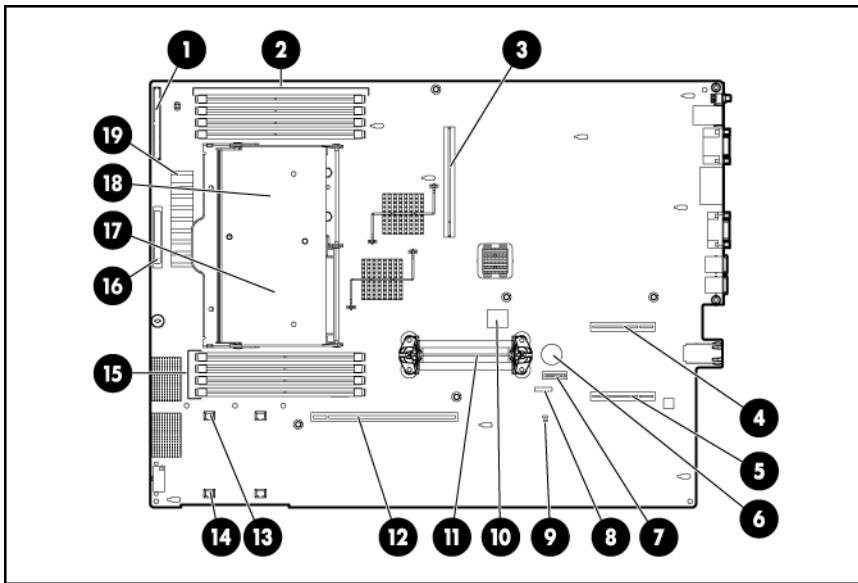

| Item | Description |
|------|----------------------------------|
| 1 | Fan board connector |
| 2 | DIMM slots (1-4) |
| 3 | Power supply backplane connector |
| 4 | PCIe slot 1 |
| 5 | PCIe slot 2 |
| 6 | System battery |
| 7 | System maintenance switch |
| 8 | Diagnostic LEDs |
| 9 | NMI jumper |
| 10 | Internal USB connector* |
| 11 | PPM 2 (for second processor) |
| 12 | PCI riser cage connector |
| 13 | Fan 2 connector |
| 14 | Fan 1 connector |
| 15 | DIMM slots (5-8) |
| 16 | Multibay interface connector |
| 17 | Processor socket 2 |
| 18 | Processor socket 1 |
| 19 | PPM 1 (embedded) |

* The lower USB connector is unavailable.

System board components (12-fan configuration)

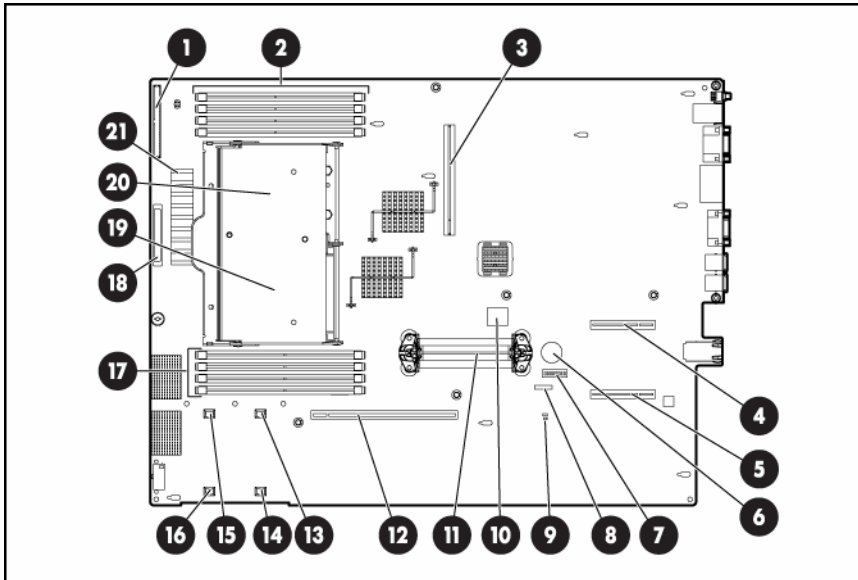

| Item | Description |
|------|----------------------------------|
| 1 | Fan board connector |
| 2 | DIMM slots (1-4) |
| 3 | Power supply backplane connector |
| 4 | PCIe slot 1 |
| 5 | PCIe slot 2 |
| 6 | System battery |
| 7 | System maintenance switch |
| 8 | Diagnostic LEDs |
| 9 | NMI jumper |
| 10 | Internal USB connector* |
| 11 | PPM 2 (for second processor) |
| 12 | PCI riser cage connector |
| 13 | Fan 4 connector |
| 14 | Fan 2 connector |
| 15 | Fan 3 connector |
| 16 | Fan 1 connector |
| 17 | DIMM slots (5-8) |
| 18 | Multibay interface connector |
| 19 | Processor socket 2 |
| 20 | Processor socket 1 |
| 21 | PPM 1 (embedded) |

* The lower USB connector is unavailable.

DIMM slots

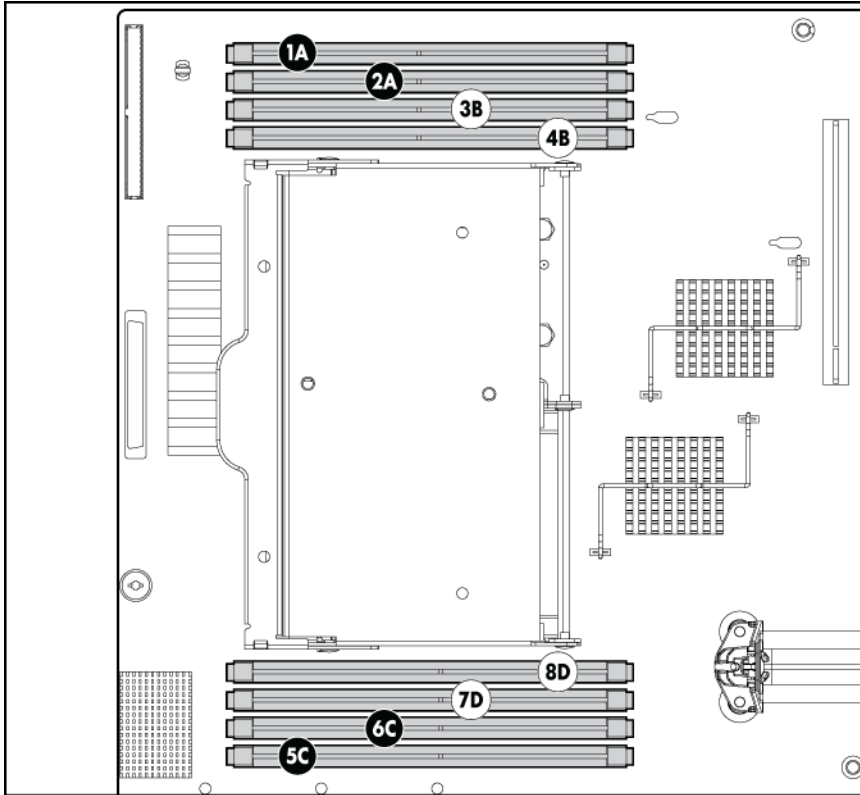

| Item | Description |
|------|--------------|
| 1 | DIMM slot 1A |
| 2 | DIMM slot 2A |
| 3 | DIMM slot 3B |
| 4 | DIMM slot 4B |
| 5 | DIMM slot 5C |
| 6 | DIMM slot 6C |
| 7 | DIMM slot 7D |
| 8 | DIMM slot 8D |

System maintenance switch

| Position | Default | Function |
|----------|---------|--|
| S1 | Off | Off = iLO 2 security is enabled. On = iLO 2 security is disabled. |
| S2 | Off | Off = System configuration can be modified. On = System configuration is locked and cannot be modified. |
| S3 | Off | Reserved |
| S4 | Off | Reserved |

| Position | Default | Function |
|----------|---------|--|
| S5 | Off | Off = Power-on password is enabled. On = Power-on password is disabled. |
| S6 | Off | Off = Normal On = ROM treats system configuration as invalid. |
| S7 | Off | Reserved |
| S8 | Off | Reserved |

When the system maintenance switch position 6 is set to the On position, the system is prepared to erase all system configuration settings from both CMOS and NVRAM.

 **CAUTION:** Clearing CMOS and/or NVRAM deletes configuration information. Be sure to properly configure the server or data loss could occur.

NMI functionality

An NMI crash dump enables administrators to create crash dump files when a system is hung and not responding to traditional debug mechanisms.

Crash dump log analysis is an essential part of diagnosing reliability problems, such as hangs in operating systems, device drivers, and applications. Many crashes freeze a system, and the only available action for administrators is to cycle the system power. Resetting the system erases any information that could support problem analysis, but the NMI feature preserves that information by performing a memory dump before a hard reset.

To force the OS to invoke the NMI handler and generate a crash dump log, the administrator can do any of the following:

- Short the NMI jumper pins
- Press the NMI switch
- Use the iLO Virtual NMI feature

For additional information, see the whitepaper on the HP website

(<http://h20000.www2.hp.com/bc/docs/support/SupportManual/c00797875/c00797875.pdf>).

Systems Insight Display LEDs and internal health LED combinations

When the internal health LED on the front panel illuminates either amber or red, the server is experiencing a health event. Combinations of illuminated system LEDs and the internal health LED indicate system status.

| Systems Insight Display LED and color | Internal Health LED color | Status |
|--|----------------------------------|---|
| Processor failure, socket X (amber) | Red | One or more of the following conditions may exist: <ul style="list-style-type: none"> • Processor in socket X has failed. • Processor X is not installed in the socket. • Processor X is unsupported. • ROM detects a failed processor during POST. |
| | Amber | Processor in socket X is in a pre-failure condition. |
| PPM failure (amber) | Red | One or more of the following conditions may exist: <ul style="list-style-type: none"> • PPM for processor 2 has failed. • PPM is not installed, but processor 2 is installed. |
| I-PPM failure (amber) | Red | Embedded I-PPM for processor 1 has failed. |
| DIMM failure, slot X (amber) | Red | One or more of the following conditions may exist: <ul style="list-style-type: none"> • DIMM in slot X has failed. • Memory group is populated with different DIMM types (all DIMMs are mismatched). |
| | Amber | One or more of the following conditions may exist: <ul style="list-style-type: none"> • DIMM in slot X is in a pre-failure condition. • Memory group is populated with different DIMM types (at least one DIMM is good). |
| DIMM failure, all slots in one bank (amber) | Red | One or more DIMMs has failed. Test each bank of DIMMs by removing all other DIMMs. Isolate the failed DIMM by replacing each DIMM in a bank with a known working DIMM. |
| DIMM failure, all slots in all banks (amber) | Red | One or more DIMMs has failed. Test each bank of DIMMs by removing all other DIMMs. Isolate the failed DIMM by replacing each DIMM in a bank with a known working DIMM. |
| Overtemperature (amber) | Red | The server has detected a hardware critical temperature level. |
| Fan (amber) | Amber | One fan has failed in redundant mode. |
| | Red | One or more of the following conditions may exist: <ul style="list-style-type: none"> • One fan has failed in non-redundant mode • The minimum fan requirements are not being met. Two or more fans have failed or are missing. |

| Systems Insight Display LED and color | Internal Health LED color | Status |
|---------------------------------------|---------------------------|-----------------------------|
| Power supply X (amber) | Red | Power supply X has failed. |
| PCI riser cage interlock (amber) | — | PCI riser cage is unseated. |

Device numbers

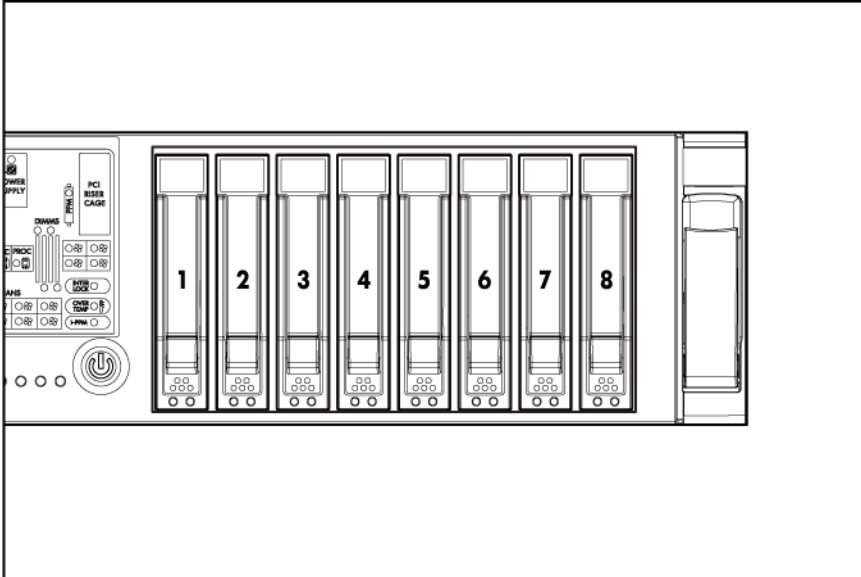

SAS and SATA hard drive LEDs

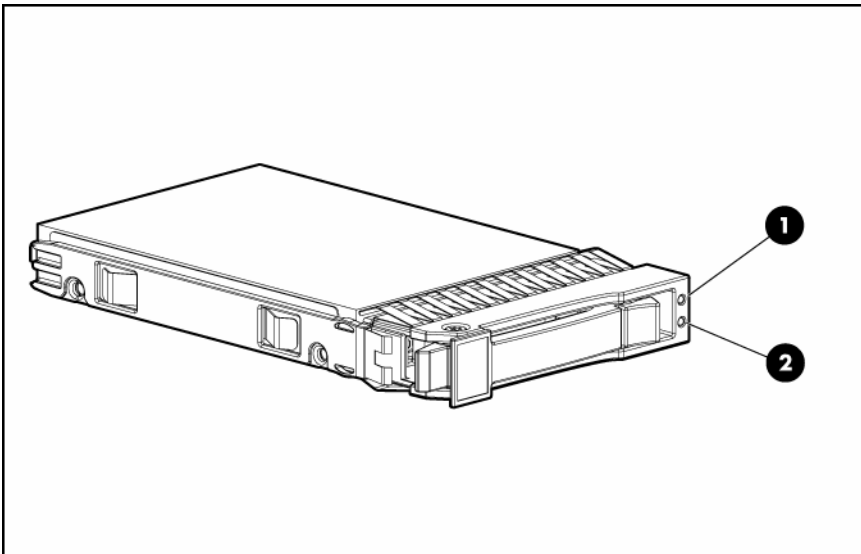

| Item | Description |
|------|----------------------------|
| 1 | Fault/UID LED (amber/blue) |
| 2 | Online LED (green) |

SAS and SATA hard drive LED combinations

| Online/activity LED (green) | Fault/UID LED (amber/blue) | Interpretation |
|-----------------------------|----------------------------------|--|
| On, off, or flashing | Alternating amber and blue | The drive has failed, or a predictive failure alert has been received for this drive; it also has been selected by a management application. |
| On, off, or flashing | Steadily blue | The drive is operating normally, and it has been selected by a management application. |
| On | Amber, flashing regularly (1 Hz) | A predictive failure alert has been received for this drive. Replace the drive as soon as possible. |
| On | Off | The drive is online, but it is not active currently. |
| Flashing regularly (1 Hz) | Amber, flashing regularly (1 Hz) | Do not remove the drive. Removing a drive may terminate the current operation and cause data loss. The drive is part of an array that is undergoing capacity expansion or stripe migration, but a predictive failure alert has been received for this drive. To minimize the risk of data loss, do not replace the drive until the expansion or migration is complete. |
| Flashing regularly (1 Hz) | Off | Do not remove the drive. Removing a drive may terminate the current operation and cause data loss. The drive is rebuilding, or it is part of an array that is undergoing capacity expansion or stripe migration. |
| Flashing irregularly | Amber, flashing regularly (1 Hz) | The drive is active, but a predictive failure alert has been received for this drive. Replace the drive as soon as possible. |
| Flashing irregularly | Off | The drive is active, and it is operating normally. |
| Off | Steadily amber | A critical fault condition has been identified for this drive, and the controller has placed it offline. Replace the drive as soon as possible. |
| Off | Amber, flashing regularly (1 Hz) | A predictive failure alert has been received for this drive. Replace the drive as soon as possible. |
| Off | Off | The drive is offline, a spare, or not configured as part of an array. |

PCI riser cage LED



CAUTION: To prevent damage to the server or expansion boards, power down the server and remove all AC power cords before removing or installing the PCI riser cage.

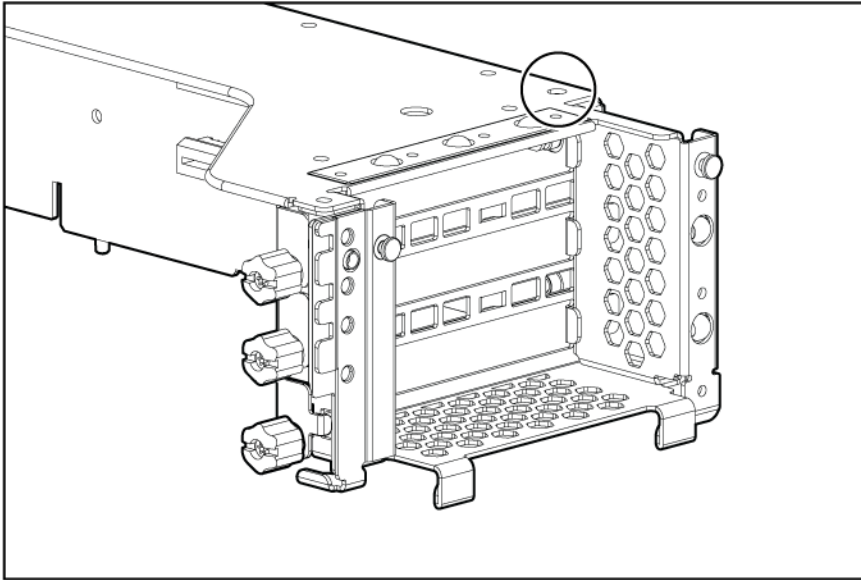

| |
|-----------------------------|
| Status |
| On = AC power connected |
| Off = AC power disconnected |

Battery pack LEDs

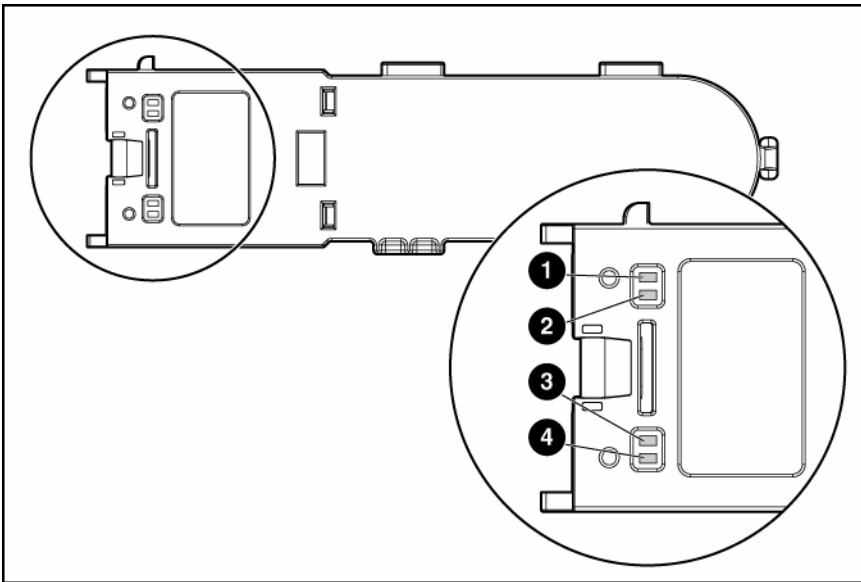

| Item ID | Color | Description |
|---------|-------|--|
| 1 | Green | System Power LED. This LED glows steadily when the system is powered up and 12 V system power is available. This power supply is used to maintain the battery charge and provide supplementary power to the cache microcontroller. |

| Item ID | Color | Description |
|---------|-------|--|
| 2 | Green | Auxiliary Power LED. This LED glows steadily when 3.3V auxiliary voltage is detected. The auxiliary voltage is used to preserve BBWC data and is available any time that the system power cords are connected to a power supply. |
| 3 | Amber | Battery Health LED. To interpret the illumination patterns of this LED, see the following table. |
| 4 | Green | BBWC Status LED. To interpret the illumination patterns of this LED, see the following table. |

| LED3 pattern | LED4 pattern | Interpretation |
|----------------------|-----------------------------|---|
| — | One blink every two seconds | The system is powered down, and the cache contains data that has not yet been written to the drives. Restore system power as soon as possible to prevent data loss. Data preservation time is extended any time that 3.3 V auxiliary power is available, as indicated by LED 2. In the absence of auxiliary power, battery power alone preserves the data. A fully-charged battery can normally preserve data for at least two days. The battery lifetime also depends on the cache module size. For further information, refer to the controller QuickSpecs on the HP website (http://www.hp.com). |
| — | Double blink, then pause | The cache microcontroller is waiting for the host controller to communicate. |
| — | One blink per second | The battery pack is below the minimum charge level and is being charged. Features that require a battery (such as write cache, capacity expansion, stripe size migration, and RAID migration) are temporarily unavailable until charging is complete. The recharge process takes between 15 minutes and two hours, depending on the initial capacity of the battery. |
| — | Steady glow | The battery pack is fully charged, and posted write data is stored in the cache. |
| — | Off | The battery pack is fully charged, and there is no posted write data in the cache. |
| One blink per second | One blink per second | An alternating green and amber blink pattern indicates that the cache microcontroller is executing from within its boot loader and receiving new flash code from the host controller. |
| Steady glow | — | There is a short circuit across the battery terminals or within the battery pack. BBWC features are disabled until the battery pack is replaced. The life expectancy of a battery pack is typically more than three years. |
| One blink per second | — | There is an open circuit across the battery terminals or within the battery pack. BBWC features are disabled until the battery pack is replaced. The life expectancy of a battery pack is typically more than three years. |

Hot-plug fans (6-fan configuration)

For server models that support six fans, the fan configuration operates in redundant mode when all six fans are installed.

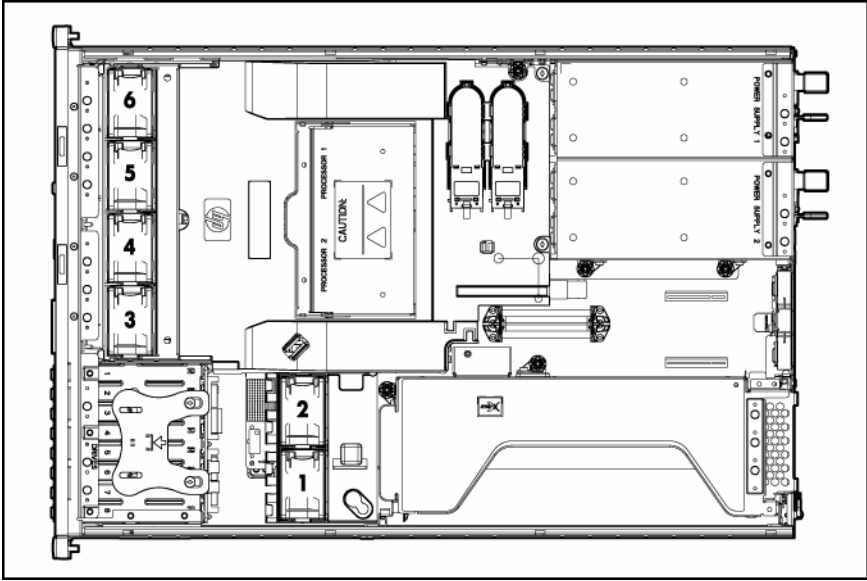

For more information, see "Hot-plug fan operation (on page 30)."

Hot-plug fans (12-fan configuration)

For server models that support 12 fans, the fan configuration operates in redundant mode when all 12 fans are installed.

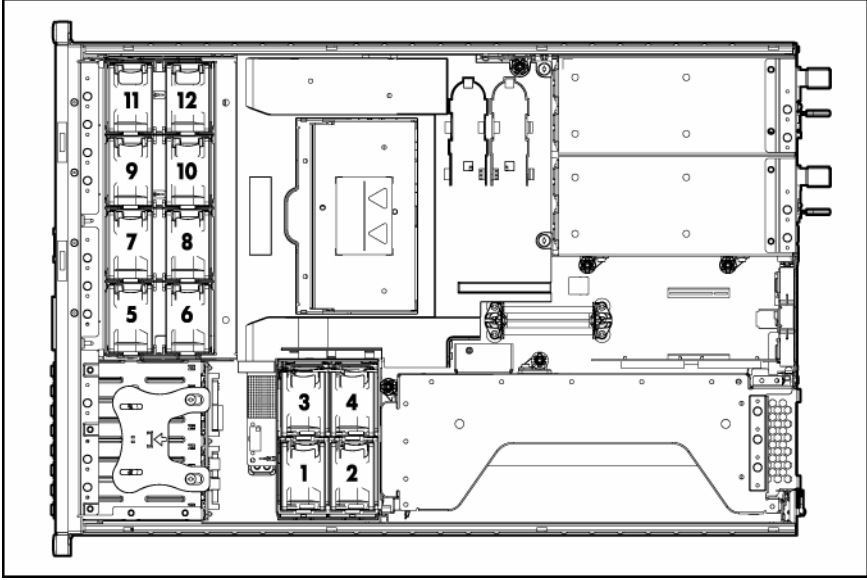

For more information, see "Hot-plug fan operation (on page 30)."

Fan board components

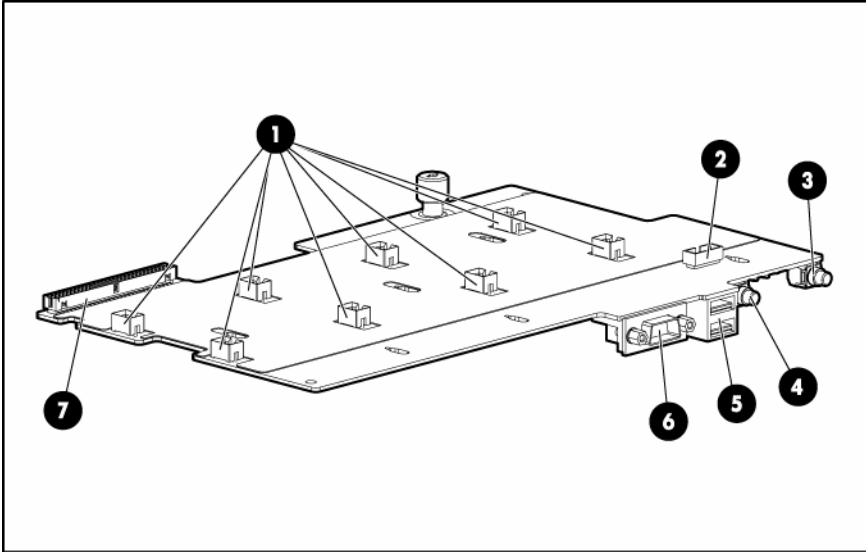

| Item | Description |
|------|--|
| 1 | Fan connectors (8)* |
| 2 | Systems Insight Display connector |
| 3 | Power On/Standby button/system power LED |
| 4 | UID LED button |
| 5 | USB connectors (2) |
| 6 | Video connector |
| 7 | Fan board system connector |

*Only the 12-fan configuration supports all connectors.

Operations

Power up the server

To power up the server, press the Power On/Standby button.

Power down the server



WARNING: To reduce the risk of personal injury, electric shock, or damage to the equipment, remove the power cord to remove power from the server. The front panel Power On/Standby button does not completely shut off system power. Portions of the power supply and some internal circuitry remain active until AC power is removed.



IMPORTANT: If installing a hot-plug device, it is not necessary to power down the server.

1. Back up the server data.
2. Shut down the operating system as directed by the operating system documentation.

NOTE: If the operating system automatically places the server in Standby mode, omit the next step.

3. Press the Power On/Standby button to place the server in Standby mode. When the server activates Standby power mode, the system power LED changes to amber.



IMPORTANT: Pressing the UID button illuminates the blue UID LEDs on the front and rear panels. In a rack environment, this feature facilitates locating a server when moving between the front and rear of the rack.

4. Disconnect the power cords.

The system is now without power.

Extend the server from the rack

1. Pull down the quick release levers on each side of the server.
2. Extend the server until the server rail-release latches engage.



WARNING: To reduce the risk of personal injury or equipment damage, be sure that the rack is adequately stabilized before extending a component from the rack.

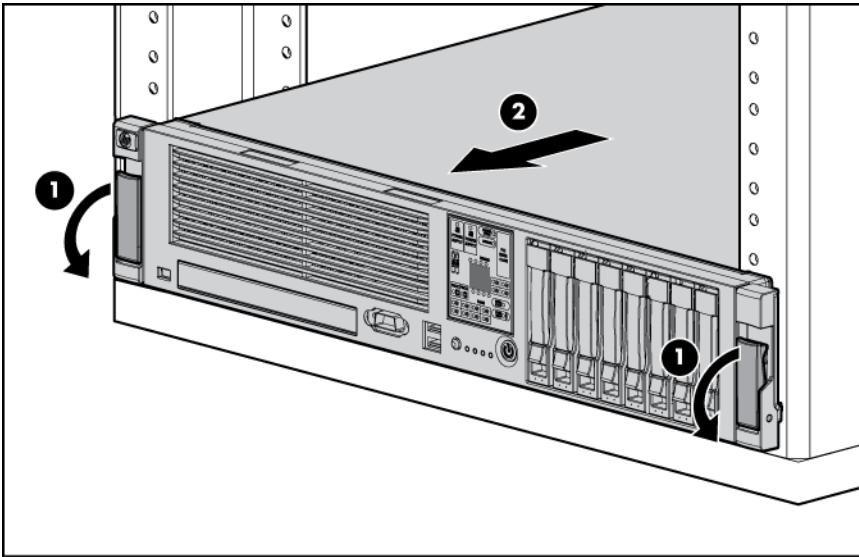

3. After performing the installation or maintenance procedure, slide the server back into the rack:
 - a. Press the server rail-release latches and slide the server fully into rack.

⚠ WARNING: To reduce the risk of personal injury, be careful when pressing the server rail-release latches and sliding the server into the rack. The sliding rails could pinch your fingers.

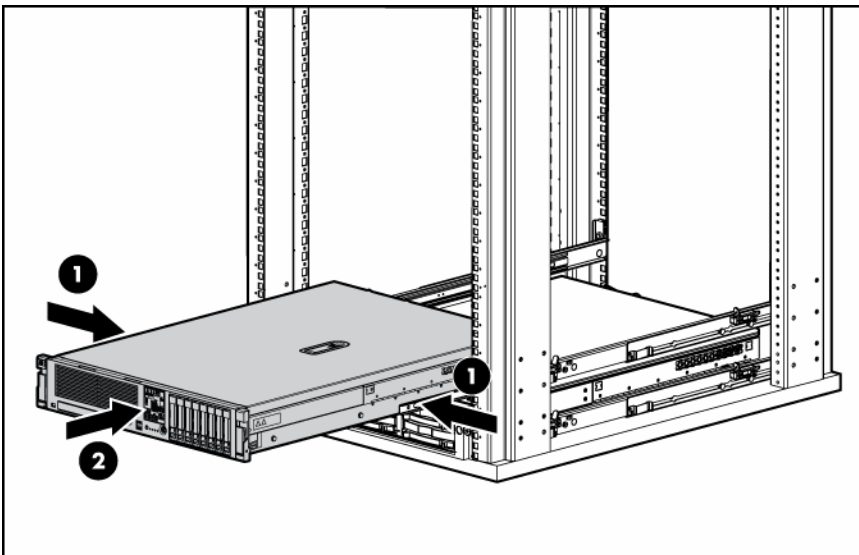

- b. Slide the server fully into the rack.

Remove the access panel

⚠ WARNING: To reduce the risk of personal injury from hot surfaces, allow the drives and the internal system components to cool before touching them.

⚠ CAUTION: Do not operate the server for long periods with the access panel open or removed. Operating the server in this manner results in improper airflow and improper cooling that can lead to thermal damage.

To remove the component:

1. Power down the server if performing a non-hot-plug installation or maintenance procedure ("[Power down the server](#)" on page 23).
2. Extend the server from the rack (on page 23).
3. Use the T-15 Torx screwdriver attached to the rear of the server to loosen the security screw on the hood latch.
4. Lift up on the hood latch handle and remove the access panel.

Install the access panel

1. Place the access panel on top of the server with the hood latch open. Allow the panel to extend past the rear of the server approximately 1.25 cm (0.5 in).
2. Push down on the hood latch. The access panel slides to a closed position.
3. Use the T-15 Torx screwdriver attached to the rear of the server to tighten the security screw on the hood latch.

Remove the air baffle



IMPORTANT: To maintain proper airflow and prevent thermal damage, always install the air baffle.

1. Power down the server (on page 23).
2. Extend or remove the server from the rack ("[Extend the server from the rack](#)" on page 23).
3. Remove the access panel (on page 24).



CAUTION: Disconnecting the battery module cable will cause any unsaved data in the cache module to be lost.

4. Disconnect the cable, and then remove the BBWC battery pack.

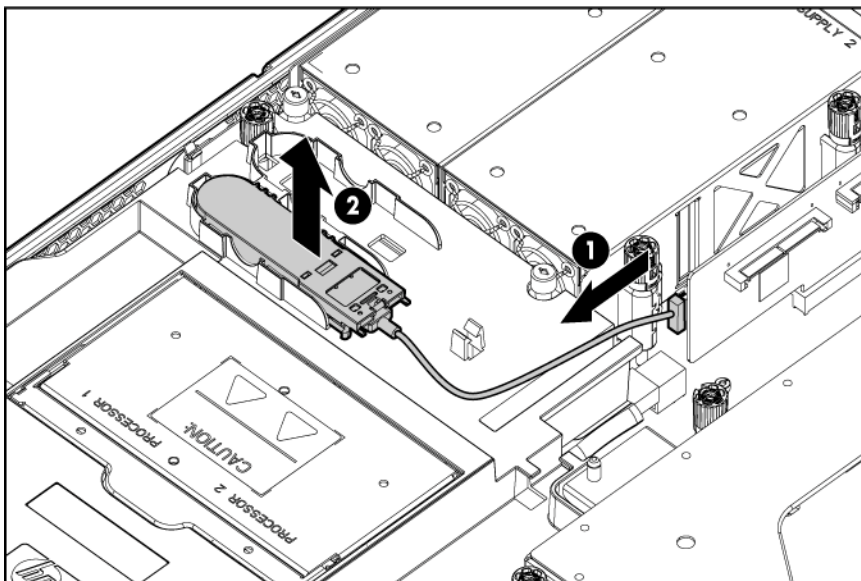

5. Remove the air baffle.

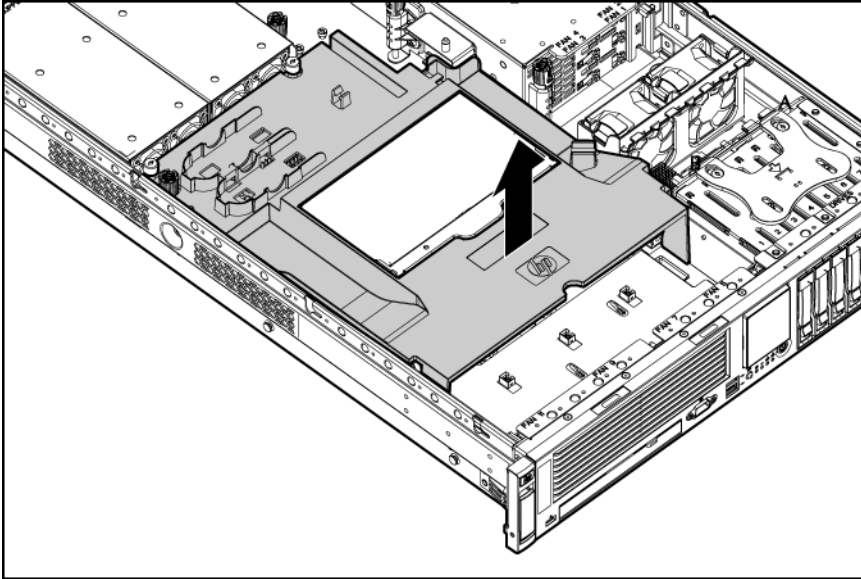

Install the air baffle



IMPORTANT: To maintain proper airflow and prevent thermal damage, always install the air baffle.

Depending on the fan configuration, the air baffle is different. Use the following procedure for either configuration.

1. Install the air baffle.

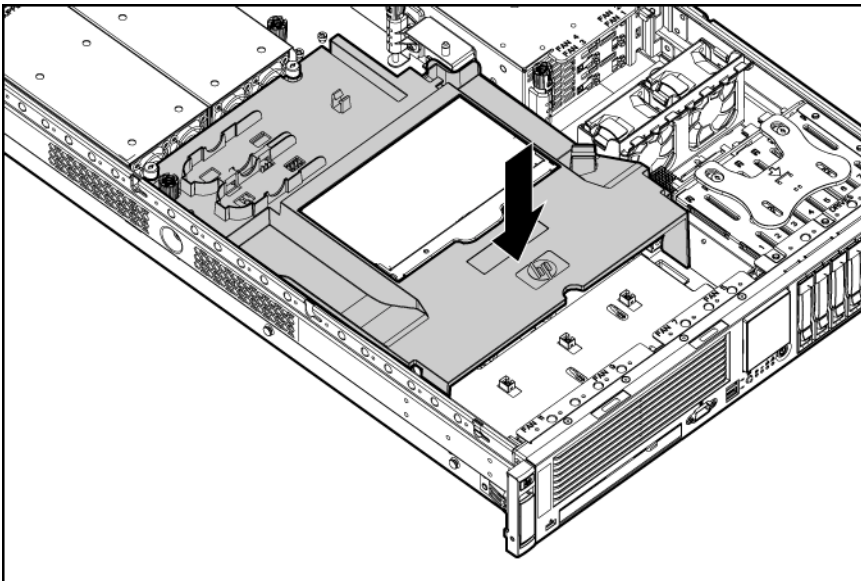

2. Install the BBWC battery pack.
3. Install the access panel (on page 25).
4. Install the server into the rack.
5. Power up the server (on page 23).

Remove the PCI riser cage

CAUTION: To prevent improper cooling and thermal damage, do not operate the server unless all PCI slots have either an expansion slot cover or an expansion board installed.

1. Power down the server (on page 23).
2. Extend the server from the rack (on page 23).
3. Remove the access panel (on page 24).
4. Disconnect any internal or external cables connected to any existing expansion boards.
5. Press the blue buttons to release the black knobs.
6. Turn the black knobs counter-clockwise.
7. Remove the PCI riser cage.

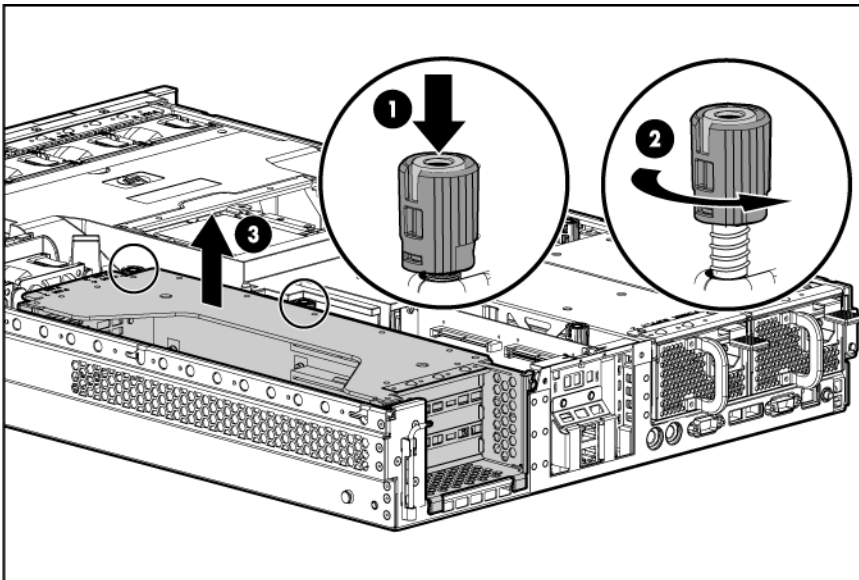

Install the PCI riser cage

CAUTION: To prevent damage to the server or expansion boards, power down the server and remove all AC power cords before removing or installing the PCI riser cage.

1. Align the PCI riser cage with the chassis and slide it into place.

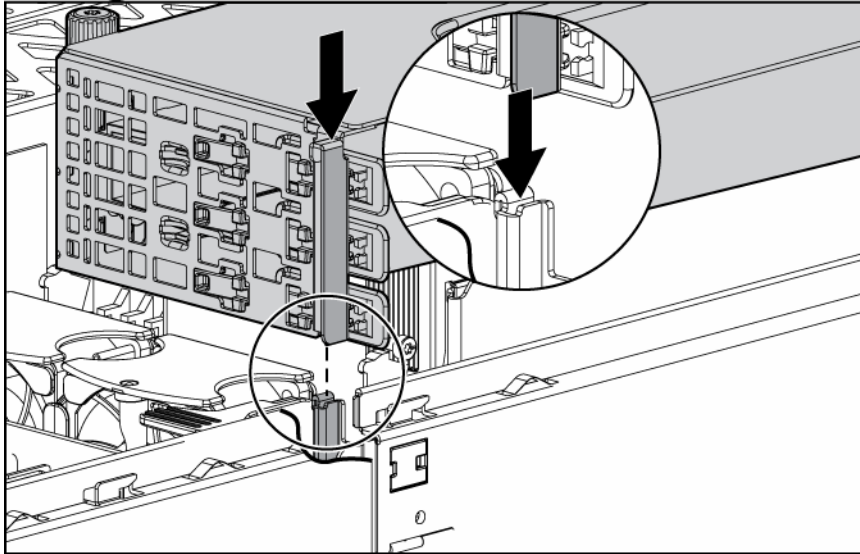

2. Tighten the thumbscrews to secure the PCI riser cage:
 - a. Press down the black knob while turning clockwise, until fully tightened.
 - b. While holding the black knob and pressing down, press and release the blue button to lower the black knob to the locked position.

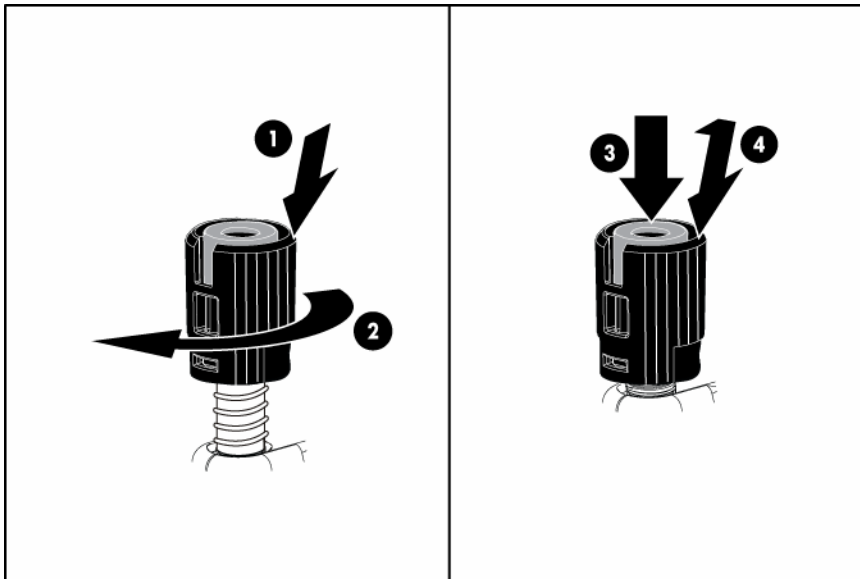

3. Connect any required internal cables to the expansion board. Refer to the documentation that ships with the expansion board.
4. Install the access panel (on page 25).
5. Install the server into the rack.
6. Connect any required external cables to the expansion board. Refer to the documentation that ships with the expansion board.
7. Power up the server (on page 23).

Access the product rear panel

Cable management arm with left-hand swing

To access the server rear panel, open the cable management arm.

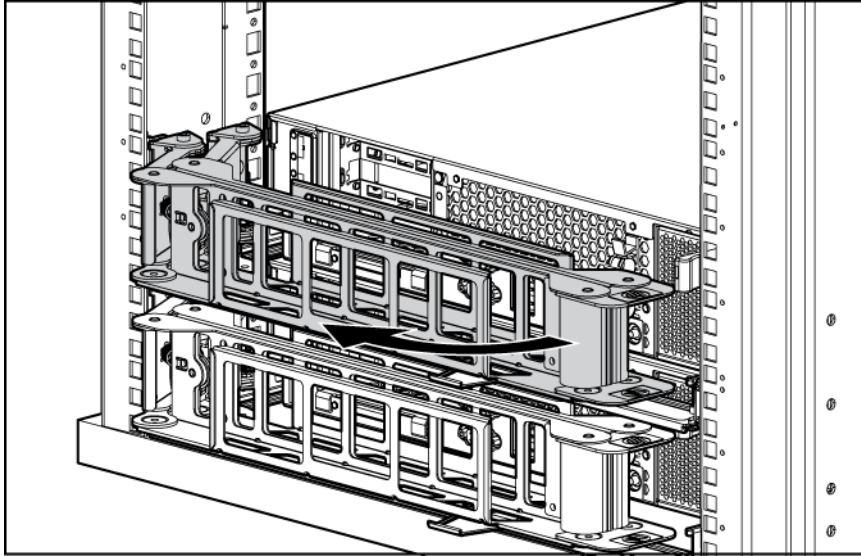

Cable management arm with right-hand swing

NOTE: To access some components, you may need to remove the cable management arm.

To access the product rear panel components, open the cable management arm:

1. Power down the server (on page 23).
2. Swing open the cable management arm.
3. Remove the cables from the cable trough.

4. Remove the cable management arm.

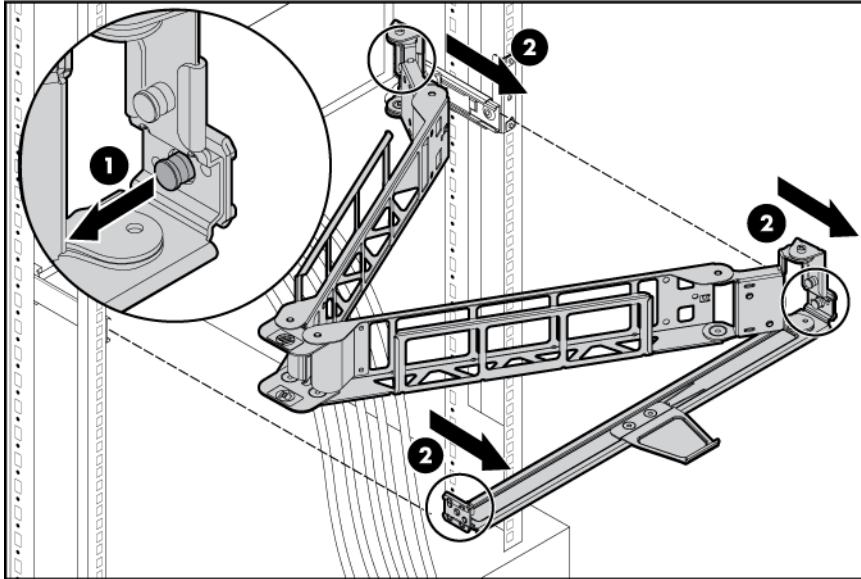

Hot-plug fan operation

The server supports variable fan speeds. The fans operate at minimum speed until a temperature change requires a fan speed increase to cool the server.

The server shuts down in the following temperature-related scenarios:

- At POST:
 - The BIOS suspends the server for 5 minutes if it detects a cautionary temperature level. If the cautionary temperature level is still detected after 5 minutes, the BIOS performs an orderly shutdown and enters Standby mode.
 - The BIOS performs an orderly shutdown if two or more fans have failed.
 - The server performs an immediate shutdown if it detects a critical temperature level.



IMPORTANT: An immediate shutdown is a hardware-controlled function and it overrides any firmware or software actions.

- In the operating system:
 - The Health Driver performs an orderly shutdown if it detects a cautionary temperature level. If the server detects a critical temperature level before the orderly shutdown occurs, the server performs an immediate shutdown. Additionally, the Health Driver performs an orderly shutdown if more than one fan is failed or removed.
 - When Thermal Shutdown is disabled in RBSU, the server performs an immediate shutdown if it detects a critical temperature level.



IMPORTANT: An immediate shutdown is a hardware-controlled function and it overrides any firmware or software actions.

Setup

Optional installation services

Delivered by experienced, certified engineers, HP Care Pack services help you keep your servers up and running with support packages tailored specifically for HP ProLiant systems. HP Care Packs let you integrate both hardware and software support into a single package. A number of service level options are available to meet your needs.

HP Care Pack Services offer upgraded service levels to expand your standard product warranty with easy-to-buy, easy-to-use support packages that help you make the most of your server investments. Some of the Care Pack services are:

- Hardware support
 - 6-Hour Call-to-Repair
 - 4-Hour 24x7 Same Day
 - 4-Hour Same Business Day
- Software support
 - Microsoft®
 - Linux
 - HP ProLiant Essentials (HP SIM and RDP)
 - VMWare
- Integrated hardware and software support
 - Critical Service
 - Proactive 24
 - Support Plus
 - Support Plus 24
- Startup and implementation services for both hardware and software

For more information on Care Packs, refer to the HP website (http://www.hp.com/hps/carepack/servers/cp_proliant.html).

Rack planning resources

The rack resource kit ships with all HP branded or Compaq branded 9000, 10000, and H9 series racks. For more information on the content of each resource, refer to the rack resource kit documentation.

If you intend to deploy and configure multiple servers in a single rack, refer to the white paper on high-density deployment at the HP website (<http://www.hp.com/products/servers/platforms>).

Optimum environment

When installing the server in a rack, select a location that meets the environmental standards described in this section.

Space and airflow requirements

To allow for servicing and adequate airflow, observe the following space and airflow requirements when deciding where to install a rack:

- Leave a minimum clearance of 63.5 cm (25 in) in front of the rack.
- Leave a minimum clearance of 76.2 cm (30 in) behind the rack.
- Leave a minimum clearance of 121.9 cm (48 in) from the back of the rack to the back of another rack or row of racks.

HP servers draw in cool air through the front door and expel warm air through the rear door. Therefore, the front and rear rack doors must be adequately ventilated to allow ambient room air to enter the cabinet, and the rear door must be adequately ventilated to allow the warm air to escape from the cabinet.

 **CAUTION:** To prevent improper cooling and damage to the equipment, do not block the ventilation openings.

When vertical space in the rack is not filled by a server or rack component, the gaps between the components cause changes in airflow through the rack and across the servers. Cover all gaps with blanking panels to maintain proper airflow.

 **CAUTION:** Always use blanking panels to fill empty vertical spaces in the rack. This arrangement ensures proper airflow. Using a rack without blanking panels results in improper cooling that can lead to thermal damage.

The 9000 and 10000 Series Racks provide proper server cooling from flow-through perforations in the front and rear doors that provide 64 percent open area for ventilation.

 **CAUTION:** When using a Compaq branded 7000 Series rack, you must install the high airflow rack door insert [P/N 327281-B21 (42U) or P/N 157847-B21 (22U)] to provide proper front-to-back airflow and cooling.

 **CAUTION:** If a third-party rack is used, observe the following additional requirements to ensure adequate airflow and to prevent damage to the equipment:

- Front and rear doors—If the 42U rack includes closing front and rear doors, you must allow 5,350 sq cm (830 sq in) of holes evenly distributed from top to bottom to permit adequate airflow (equivalent to the required 64 percent open area for ventilation).
 - Side—The clearance between the installed rack component and the side panels of the rack must be a minimum of 7 cm (2.75 in).
-

Temperature requirements

To ensure continued safe and reliable equipment operation, install or position the system in a well-ventilated, climate-controlled environment.

The maximum recommended ambient operating temperature (TMRA) for most server products is 35°C (95°F). The temperature in the room where the rack is located must not exceed 35°C (95°F).

-
-  **CAUTION:** To reduce the risk of damage to the equipment when installing third-party options:
- Do not permit optional equipment to impede airflow around the server or to increase the internal rack temperature beyond the maximum allowable limits.
 - Do not exceed the manufacturer's TMRA.
-

Power requirements

Installation of this equipment must comply with local and regional electrical regulations governing the installation of information technology equipment by licensed electricians. This equipment is designed to operate in installations covered by NFPA 70, 1999 Edition (National Electric Code) and NFPA-75, 1992 (code for Protection of Electronic Computer/Data Processing Equipment). For electrical power ratings on options, refer to the product rating label or the user documentation supplied with that option.

-
-  **WARNING:** To reduce the risk of personal injury, fire, or damage to the equipment, do not overload the AC supply branch circuit that provides power to the rack. Consult the electrical authority having jurisdiction over wiring and installation requirements of your facility.
-

-  **CAUTION:** Protect the server from power fluctuations and temporary interruptions with a regulating uninterruptible power supply (UPS). This device protects the hardware from damage caused by power surges and voltage spikes and keeps the system in operation during a power failure.
-

When installing more than one server, you may need to use additional power distribution devices to safely provide power to all devices. Observe the following guidelines:



- Balance the server power load between available AC supply branch circuits.
- Do not allow the overall system AC current load to exceed 80 percent of the branch circuit AC current rating.
- Do not use common power outlet strips for this equipment.
- Provide a separate electrical circuit for the server.

Electrical grounding requirements

The server must be grounded properly for proper operation and safety. In the United States, you must install the equipment in accordance with NFPA 70, 1999 Edition (National Electric Code), Article 250, as well as any local and regional building codes. In Canada, you must install the equipment in accordance with Canadian Standards Association, CSA C22.1, Canadian Electrical Code. In all other countries, you must install the equipment in accordance with any regional or national electrical wiring codes, such as the International Electrotechnical Commission (IEC) Code 364, parts 1 through 7. Furthermore, you must be sure that all power distribution devices used in the installation, such as branch wiring and receptacles, are listed or certified grounding-type devices.

Because of the high ground-leakage currents associated with multiple servers connected to the same power source, HP recommends the use of a PDU that is either permanently wired to the building's branch circuit or includes a nondetachable cord that is wired to an industrial-style plug. NEMA locking-style plugs or those complying with IEC 60309 are considered suitable for this purpose. Using common power outlet strips for the server is not recommended.

Rack warnings

-
-  **WARNING:** To reduce the risk of personal injury or damage to the equipment, be sure that:
- The leveling jacks are extended to the floor.
 - The full weight of the rack rests on the leveling jacks.
 - The stabilizing feet are attached to the rack if it is a single-rack installation.
 - The racks are coupled together in multiple-rack installations.
 - Only one component is extended at a time. A rack may become unstable if more than one component is extended for any reason.
-
-  **WARNING:** To reduce the risk of personal injury or equipment damage when unloading a rack:
- At least two people are needed to safely unload the rack from the pallet. An empty 42U rack can weigh as much as 115 kg (253 lb), can stand more than 2.1 m (7 ft) tall, and may become unstable when being moved on its casters.
 - Never stand in front of the rack when it is rolling down the ramp from the pallet. Always handle the rack from both sides.
-
-  **WARNING:** Components can be very heavy. To reduce the risk of personal injury or damage to the equipment:
- Remove all pluggable power supplies and modules to reduce the weight of the product before lifting it.
 - Observe local occupational health and safety requirements and guidelines for manual material handling.
 - Get help to lift and stabilize the product during installation or removal, especially when the product is not fastened to the rails. When the component weighs more than 22.5 kg (50 lb), at least two people must lift the component into the rack together. If the component is loaded into the rack above chest level, a third person must assist in aligning the rails while the other two support the component.
 - Use caution when installing the component in or removing the component from the rack; it is unstable when not fastened to the rails.
-

Identifying the contents of the server shipping carton

Unpack the server shipping carton and locate the materials and documentation necessary for installing the server. All the rack mounting hardware necessary for installing the server into the rack is included with the rack or the server.

The contents of the server shipping carton include:

- Server
- Power cord
- Hardware documentation, Documentation CD, and software products
- Rack-mounting hardware

In addition to the supplied items, you may need:

- Operating system or application software
- Hardware options

Installing hardware options

Install any hardware options before initializing the server. For options installation information, refer to the option documentation. For server-specific information, refer to "Hardware options installation (on page 39)."

Installing the server into the rack

CAUTION: Always plan the rack installation so that the heaviest item is on the bottom of the rack. Install the heaviest item first, and continue to populate the rack from the bottom to the top.

1. Install the server and cable management arm into the rack. For more information, refer to the installation instructions that ship with the 2U Quick Deploy Rail System.
2. Connect peripheral devices to the server.

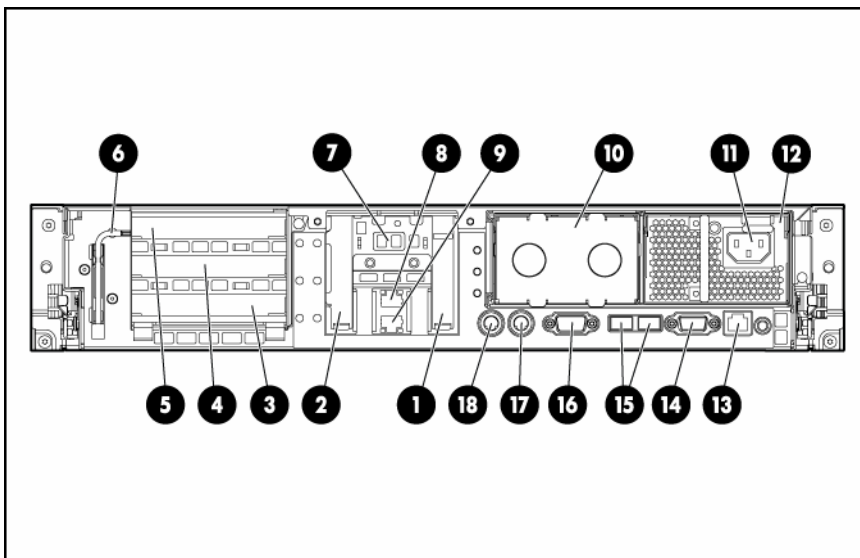

| Item | Description | Color |
|------|----------------------------|-------|
| 1 | Expansion slot 1 | — |
| 2 | Expansion slot 2 | — |
| 3 | Expansion slot 3 | — |
| 4 | Expansion slot 4 | — |
| 5 | Expansion slot 5 | — |
| 6 | T-10/T-15 Torx screwdriver | — |
| 7 | External option blank | — |
| 8 | NIC 2 connector | — |
| 9 | NIC 1 connector | — |

| | | |
|----|--------------------------------|--------|
| 10 | Power supply bay 2 | — |
| 11 | Power cord connector | Black |
| 12 | Power supply bay 1 (populated) | — |
| 13 | iLO 2 connector | — |
| 14 | Video connector | Blue |
| 15 | USB connectors (2) | Black |
| 16 | Serial connector | — |
| 17 | Mouse connector | Green |
| 18 | Keyboard connector | Purple |



WARNING: To reduce the risk of electric shock, fire, or damage to the equipment, do not plug telephone or telecommunications connectors into RJ-45 connectors.

3. Connect the power cord to the rear of the server.
4. Install the power cord anchor on the handle of the power supply.

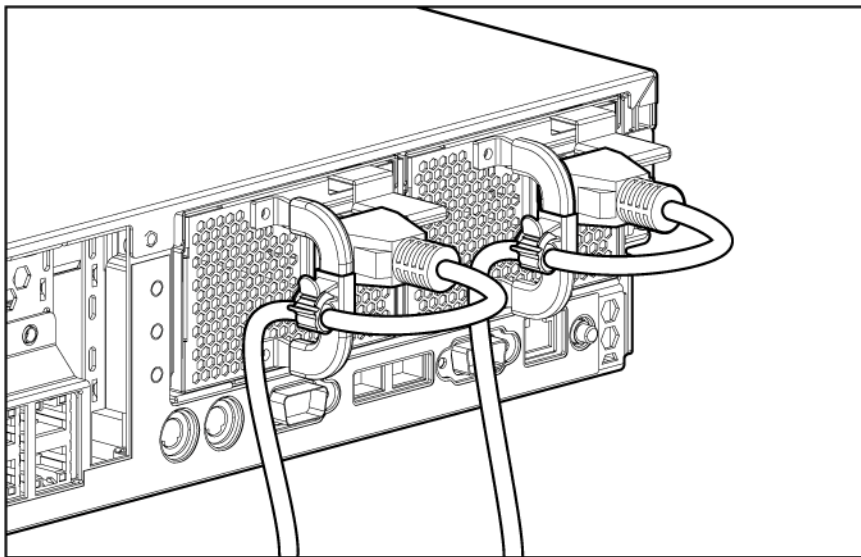

NOTE: Peripheral device cables are removed for clarity.

5. Secure cables to the cable management arm.



IMPORTANT: When using cable management arm components, be sure to leave enough slack in each of the cables to prevent damage to the cables when the server is extended from the rack.

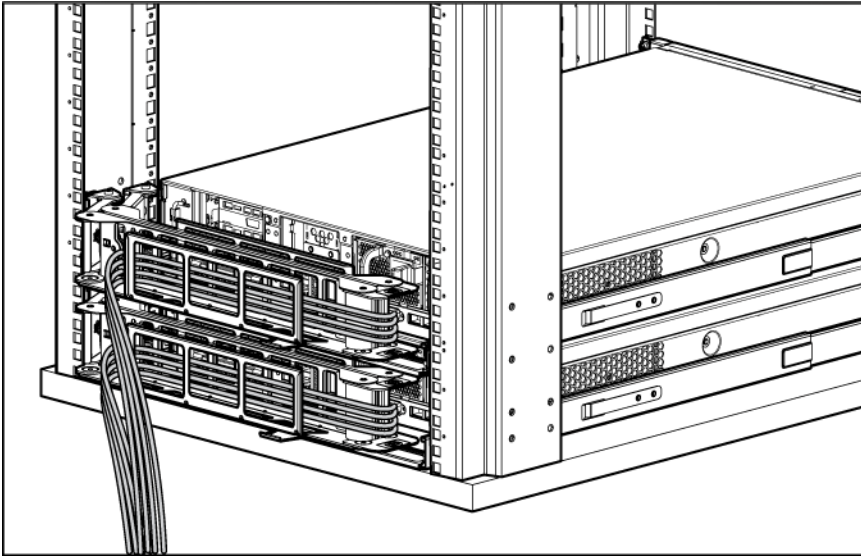

6. Connect the power cord to the AC power source.



WARNING: To reduce the risk of electric shock or damage to the equipment:

- Do not disable the power cord grounding plug. The grounding plug is an important safety feature.
- Plug the power cord into a grounded (earthed) electrical outlet that is easily accessible at all times.
- Unplug the power cord from the power supply to disconnect power to the equipment.
- Do not route the power cord where it can be walked on or pinched by items placed against it. Pay particular attention to the plug, electrical outlet, and the point where the cord extends from the server.

Powering up and configuring the server

To power up the server, press the Power On/Standby button.

While the server boots, RBSU and the ORCA utility are automatically configured to prepare the server for operating system installation.

To configure these utilities manually:

- Press the **F8** key when prompted during the array controller initialization to configure the array controller using ORCA.
- Press the **F9** key when prompted during the boot process to change the server settings using RBSU. The system is set up by default for the English language.

For more information on the automatic configuration, refer to the *HP ROM-Based Setup Utility User Guide* located on the Documentation CD.

Installing the operating system

To operate properly, the server must have a supported operating system installed. For the latest information on supported operating systems, refer to the HP website (<http://www.hp.com/go/supportos>).

Methods to install an operating system on the server include:

- SmartStart assisted installation—Insert the SmartStart CD into the CD-ROM drive and reboot the server.
- Manual installation—Insert the operating system CD into the CD-ROM drive and reboot the server. This process may require you to obtain additional drivers from the HP website (<http://www.hp.com/support>).

For information on using these installation paths, refer to the SmartStart installation poster in the HP ProLiant Essentials Foundation Pack, included with the server.

Registering the server

To register the server, refer to the HP Registration website (<http://register.hp.com>).

Hardware options installation

Introduction

If more than one option is being installed, read the installation instructions for all the hardware options and identify similar steps to streamline the installation process.

-
-  **WARNING:** To reduce the risk of personal injury from hot surfaces, allow the drives and the internal system components to cool before touching them.

 -  **CAUTION:** To prevent damage to electrical components, properly ground the server before beginning any installation procedure. Improper grounding can cause electrostatic discharge.

Processor option

The server supports single- and dual-processor operation. The server uses PPMs to provide power to each processor.

-
-  **CAUTION:** To avoid damage to the processor and system board, only authorized personnel should attempt to replace or install the processor in this server.

 -  **CAUTION:** To help avoid damage to the processor and system board, do not install the processor without using the processor installation tool.

 -  **CAUTION:** To prevent possible server malfunction and damage to the equipment, multiprocessor configurations must contain processors with the same part number.

 -  **IMPORTANT:** If upgrading processor speed, update the system ROM before installing the processor.

 -  **IMPORTANT:** Processor socket 1 must be populated at all times or the server does not function properly.

To install a processor:

1. Power down the server (on page [23](#)).
2. Extend the server from the rack (on page [23](#)).
3. Remove the access panel (on page [24](#)).
4. Remove the air baffle (on page [25](#)).

5. Open the heatsink retaining bracket.

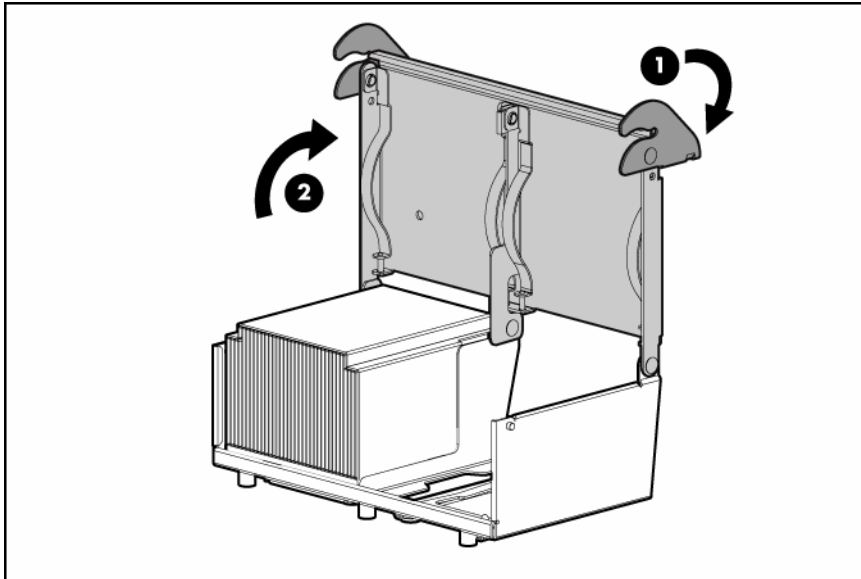

CAUTION: The pins on the processor socket are very fragile. Any damage to them may require replacing the system board.

6. Remove the processor socket protective cover. Retain the cover for future use.

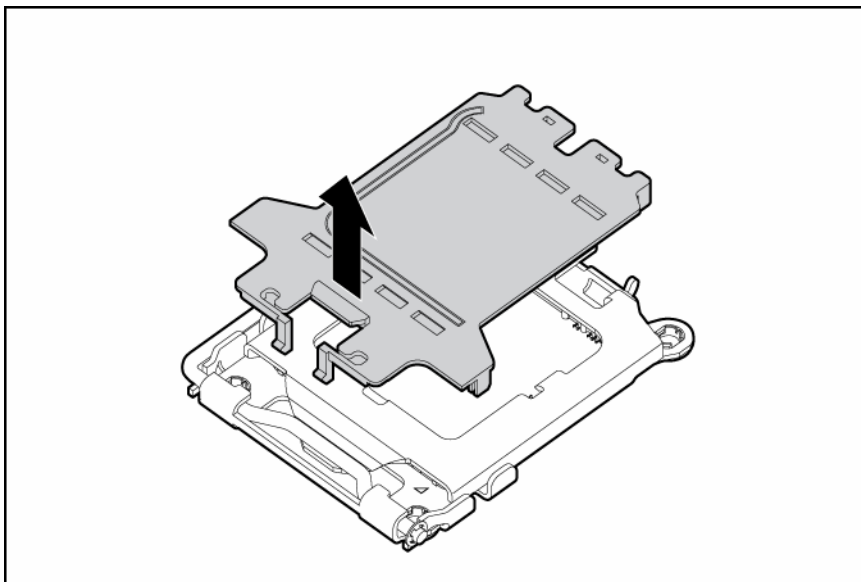

CAUTION: Failure to completely open the processor locking lever prevents the processor from seating during installation, leading to hardware damage.

7. Rotate the latch and open the retaining bracket.

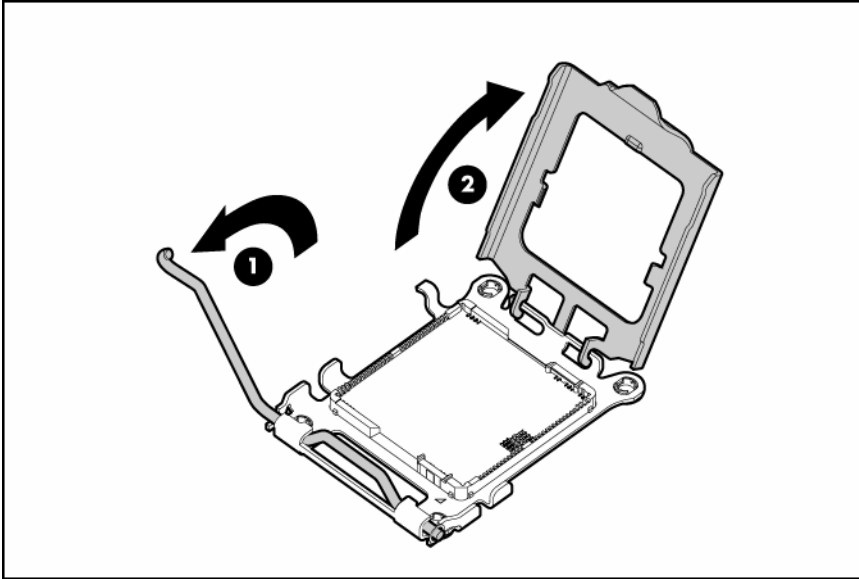

IMPORTANT: Be sure the processor remains inside the processor installation tool.

8. If the processor has separated from the installation tool, carefully re-insert the processor in the tool.

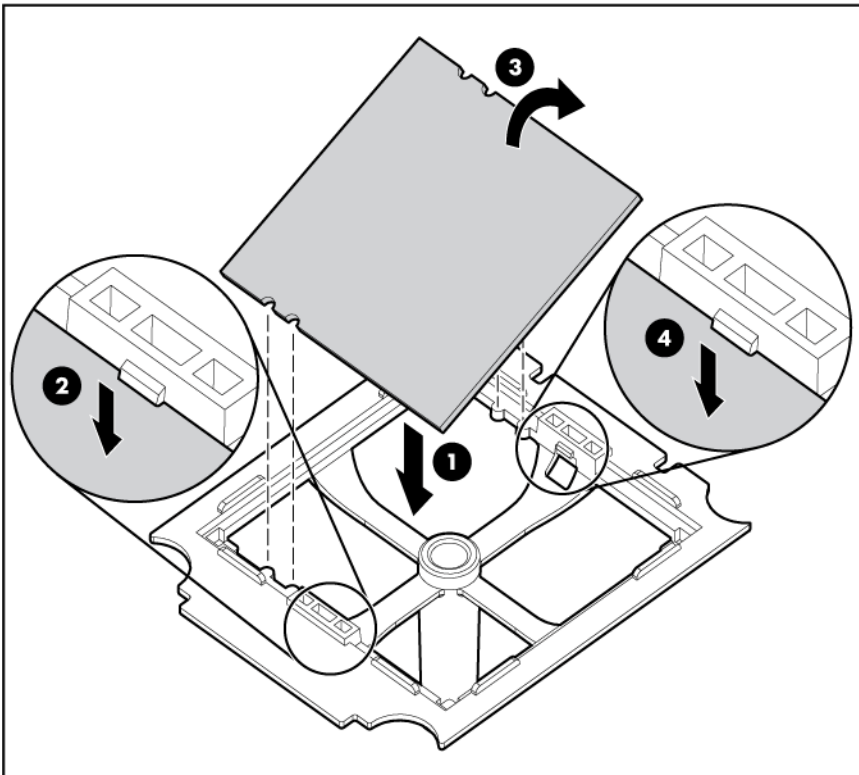

9. Align the processor installation tool with the socket and install the processor.



CAUTION: The processor is designed to fit one way into the socket. Use the alignment guides on the processor and socket to properly align the processor with the socket.

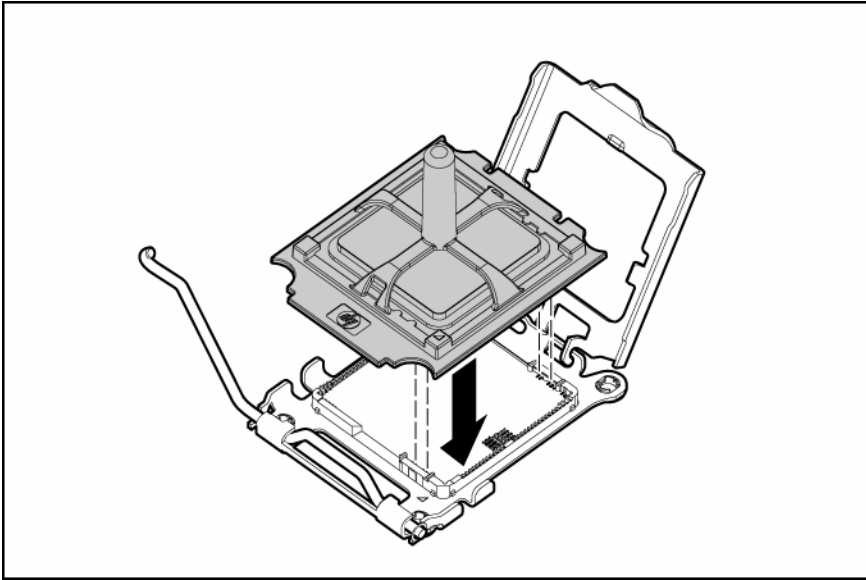

10. Press down firmly until the processor installation tool clicks and separates from the processor, and then remove the processor installation tool.

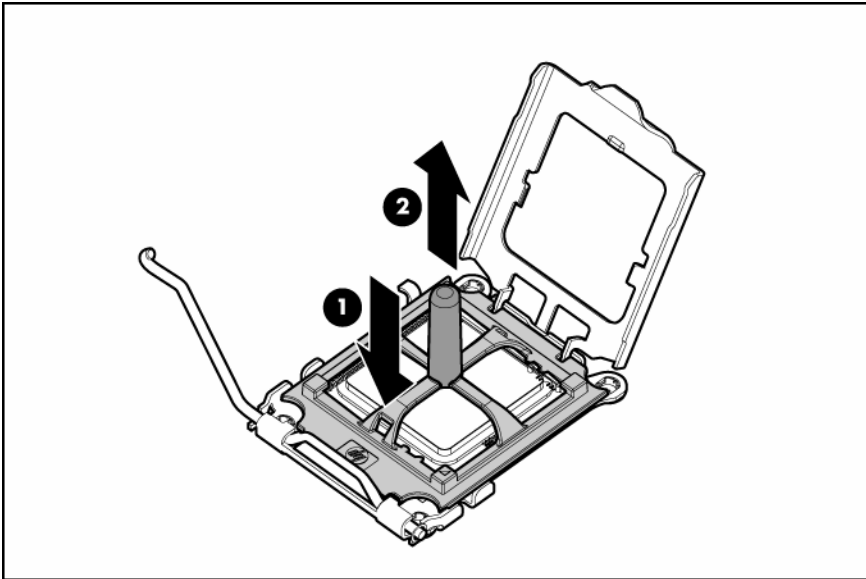

11. Close the processor retaining bracket and the processor retaining latch.

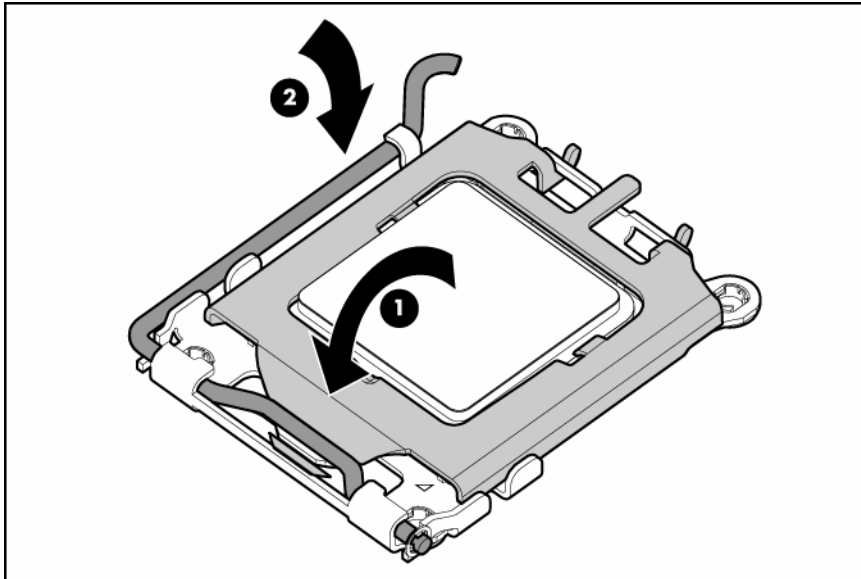

- ⚠ **CAUTION:** To prevent possible server malfunction or damage to the equipment, be sure to completely close the processor locking lever.

12. Remove the heatsink cover.

- ⚠ **CAUTION:** After the cover is removed, do not touch the thermal interface media.

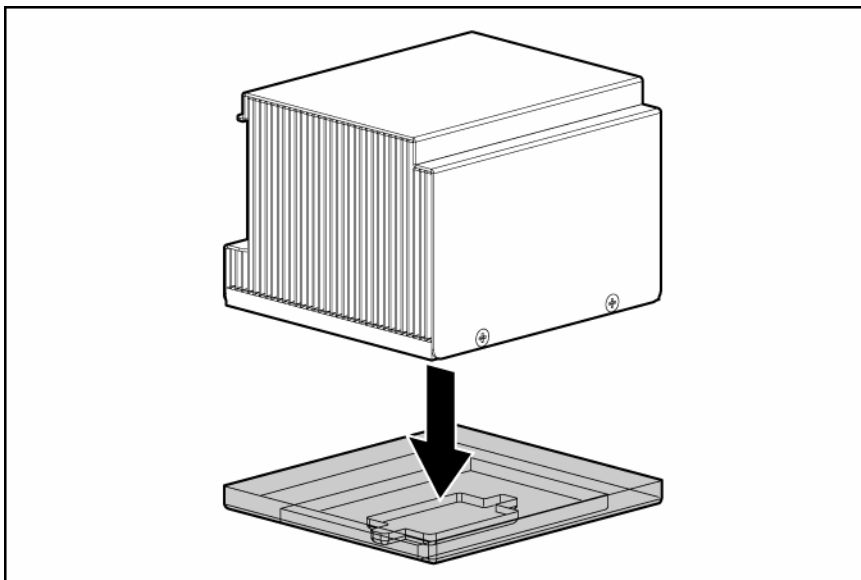

13. Install the heatsink.

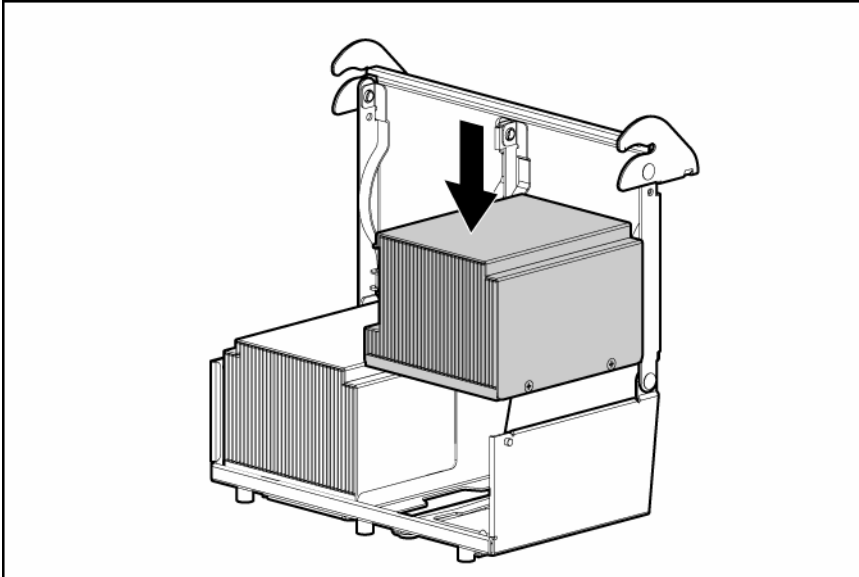

14. Close the heatsink retaining bracket.

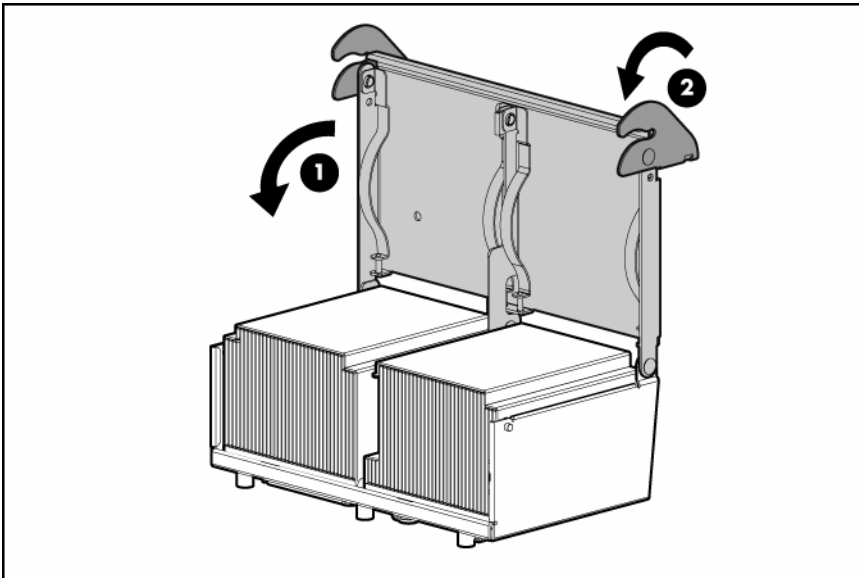

15. Install the PPM:
a. Open the latches on the corresponding PPM slot.



IMPORTANT: Install the PPM only when installing a second processor.

NOTE: The PPM is keyed and the key must be aligned when installed.

- b. Install the PPM.

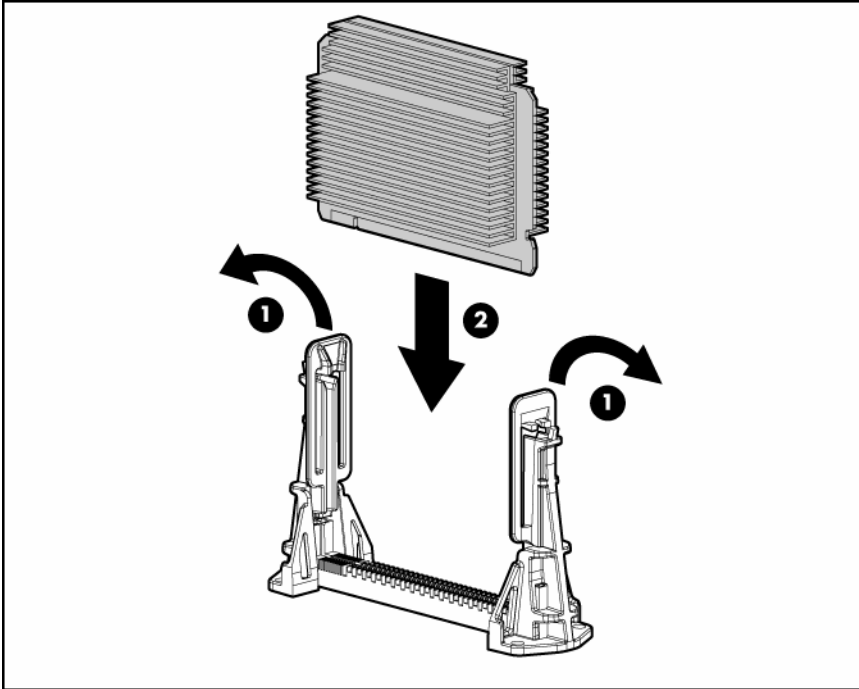

- c. Close the latches.

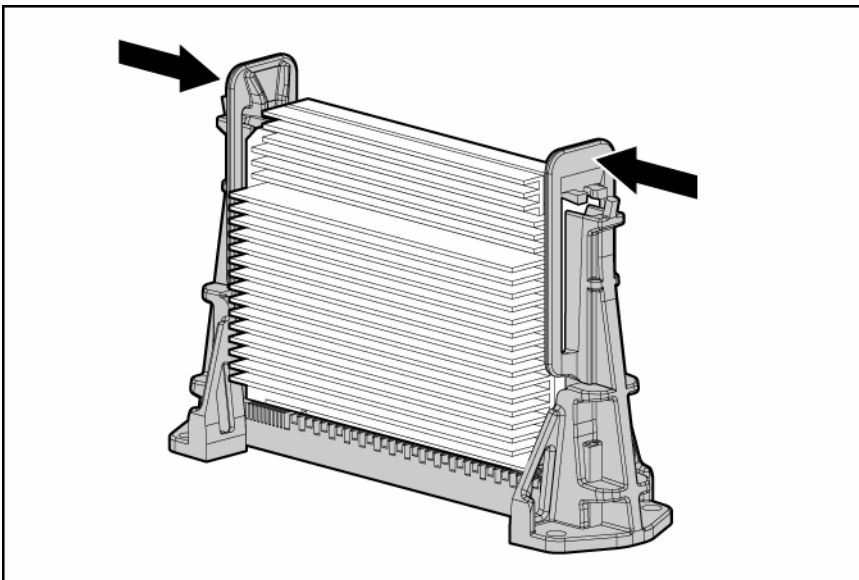

NOTE: The appearance of compatible PPMs may vary.

16. Install the air baffle (on page 26).
17. Install the access panel (on page 25).
18. Install the server into the rack.
19. Power up the server (on page 23).

Memory options

You can expand server memory by installing PC2-5300 Registered DDR2 SDRAM DIMMs. The server supports up to 32 GB of memory using eight 4-GB DIMMs (four DIMMs per processor).

NOTE: The Advanced Memory Protection option in RBSU provides additional memory protection beyond Advanced ECC. By default, the server is set to **Advanced ECC Support**. For more information, refer to "HP ROM-Based Setup Utility (on page 63)."

For DIMM slot locations and bank assignments, see "DIMM slots (on page 14)."

Advanced ECC memory

Advanced ECC memory is the default memory protection mode for this server. In Advanced ECC, the server is protected against correctable memory errors. The server provides notification if the level of correctable errors exceeds a pre-defined threshold rate. The server does not fail because of correctable memory errors. Advanced ECC provides additional protection over Standard ECC because it is possible to correct certain memory errors that would otherwise be uncorrectable and result in a server failure.

Whereas standard ECC can correct single-bit memory errors, Advanced ECC can correct single-bit memory errors and multi-bit memory errors if all failed bits are on the same DRAM device on the DIMM.

DIMM installation guidelines

Observe the following guidelines when installing additional memory:

- Always install memory in pairs of two identical DIMMs.
- Install only ECC PC2-5300 Registered DDR2 SDRAM DIMMs that meet the following specifications:
 - Supply voltage: 1.8 V
 - Bus width: 72 bits
- Install DIMMs with the same speed.
- Install memory in pairs (banks) beginning with banks farthest away from each populated processor (banks A and C).
- The server supports multiple memory modes, based on DIMM population. Use RBSU ("HP ROM-Based Setup Utility" on page 63) to select a mode (System will default to Advanced ECC).
- Observe the following special conditions when installing memory with a second processor:
 - Processor 2 can be installed without memory.
 - Any memory installed into banks for processor 2 can be used only if processor 2 is installed.



CAUTION: Always wear an antistatic wrist strap when working inside the server.

DIMM population order

| Configuration | Bank A 1A and 2A | Bank B 3B and 4B | Bank C 5C and 6C | Bank D 7D and 8D |
|------------------|---------------------|---------------------|---------------------|---------------------|
| Single processor | 1st | 2nd | — | — |
| Dual processor | 1st | 3rd | 2nd | 4th |

Installing DIMMs

1. Power down the server (on page 23).
2. Extend the server from the rack (on page 23).
3. Remove the access panel (on page 24).
4. Remove the air baffle (on page 25).
5. Open the DIMM slot latches.



IMPORTANT: Always install memory in pairs of two identical DIMMs.

6. Install the DIMM.

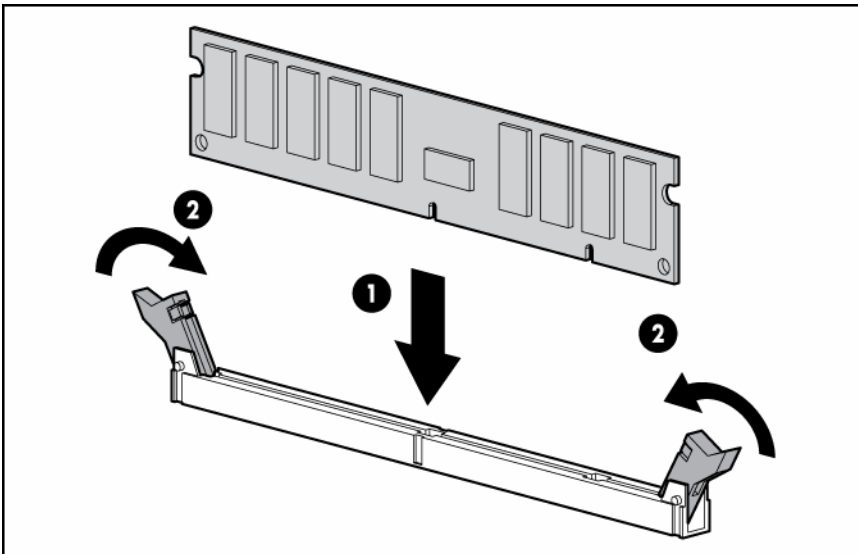

7. Install the air baffle (on page 26, "Remove the air baffle" on page 25).
8. Install the access panel (on page 25).
9. Install the server into the rack.
10. Power up the server (on page 23).

For more information about LEDs and troubleshooting failed DIMMs, see "Systems Insight Display LEDs and internal health LED combinations (on page 15)."

Hot-plug SAS hard drive options

When adding hard drives to the server, observe the following general guidelines:

- The system automatically sets all device numbers.
- If only one hard drive is used, install it in the bay with the lowest device number.
- Hard drives must be SFF types.
- Drives should be the same capacity to provide the greatest storage space efficiency when drives are grouped together into the same drive array.

Installing a hot-plug SAS hard drive

1. Remove the SAS hard drive blank.

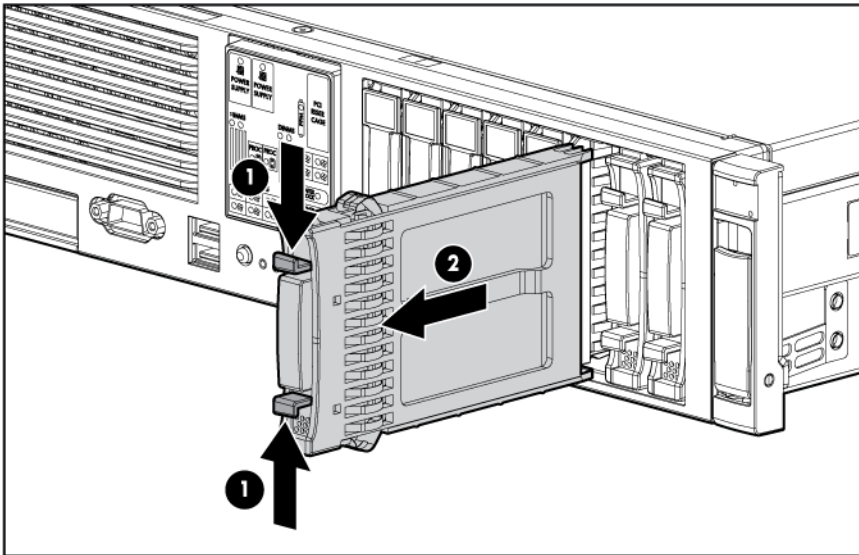

2. Prepare the hard drive.

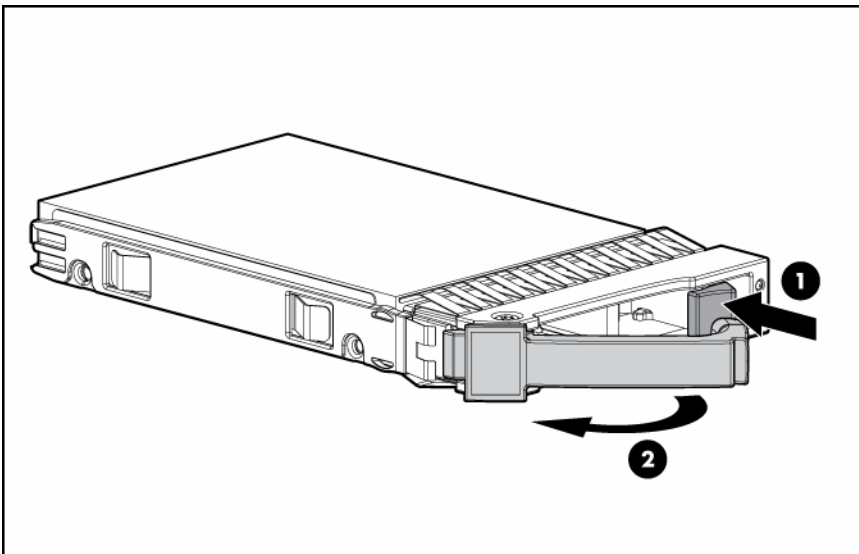

3. Install the hard drive.

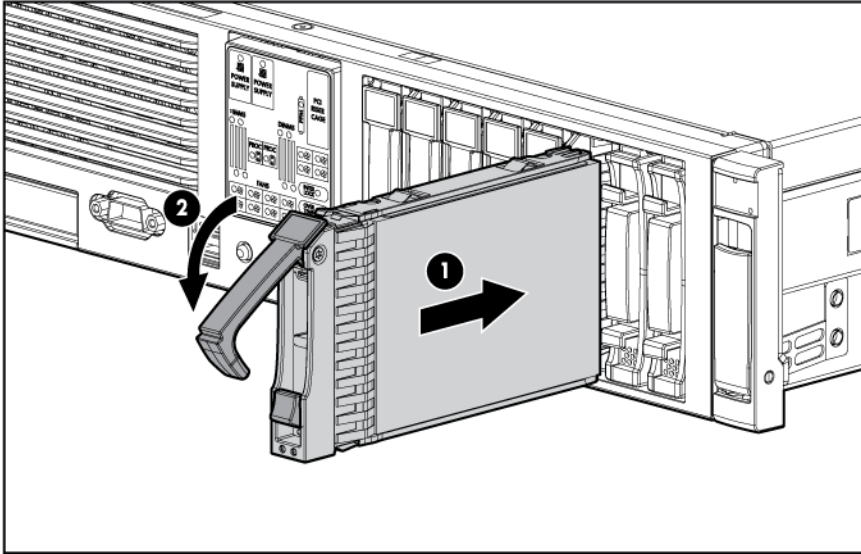

4. Determine the status of the hard drive from the hot-plug SAS hard drive LED combinations ("[SAS and SATA hard drive LED combinations](#)" on page 18).

Removing a hot-plug SAS hard drive

CAUTION: To prevent improper cooling and thermal damage, do not operate the server unless all bays are populated with either a component or a blank.

1. Determine the status of the hard drive from the hot-plug SAS hard drive LED combinations ("[SAS and SATA hard drive LED combinations](#)" on page 18).
2. Back up all server data on the hard drive.
3. Remove the hard drive.

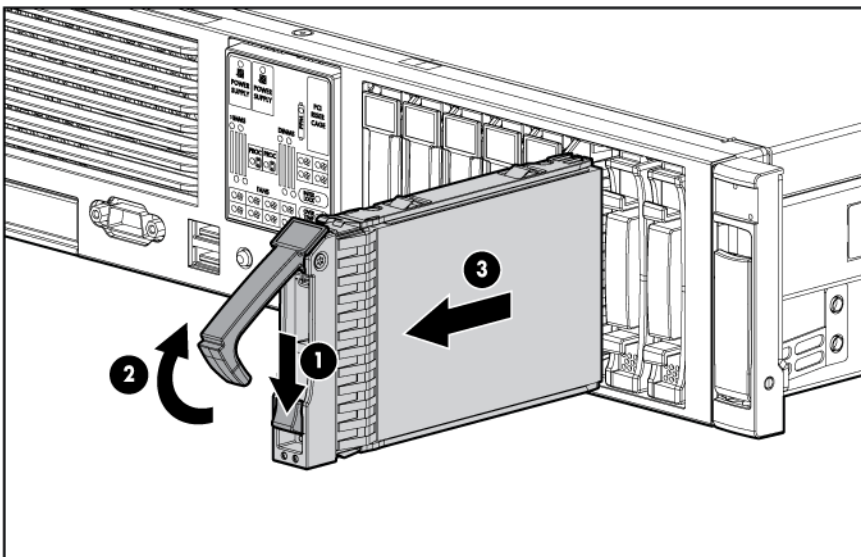

Media drive option

1. Power down the server (on page 23).
2. Remove the existing media drive option or blank.

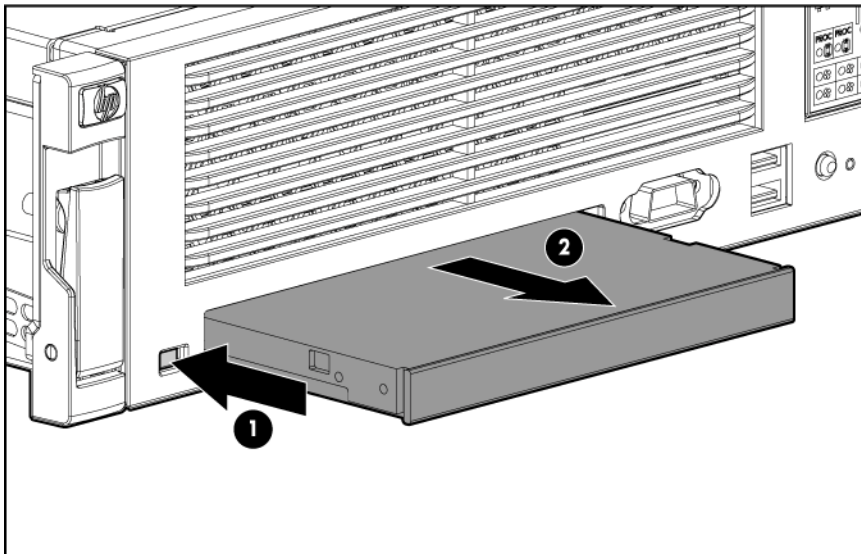

3. Slide the CD/DVD-ROM drive or diskette drive into the drive bay.

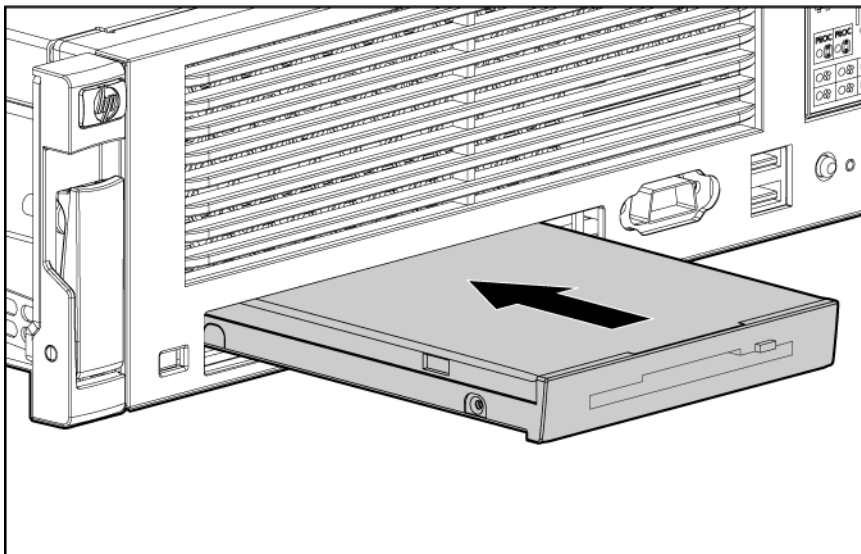

Redundant hot-plug AC power supply option

CAUTION: To prevent improper cooling and thermal damage, do not operate the server unless all bays are populated with either a component or a blank.

1. Access the product rear panel (on page 29).
2. Remove the power supply blank.

WARNING: To reduce the risk of personal injury from hot surfaces, allow the power supply or power supply blank to cool before touching it.

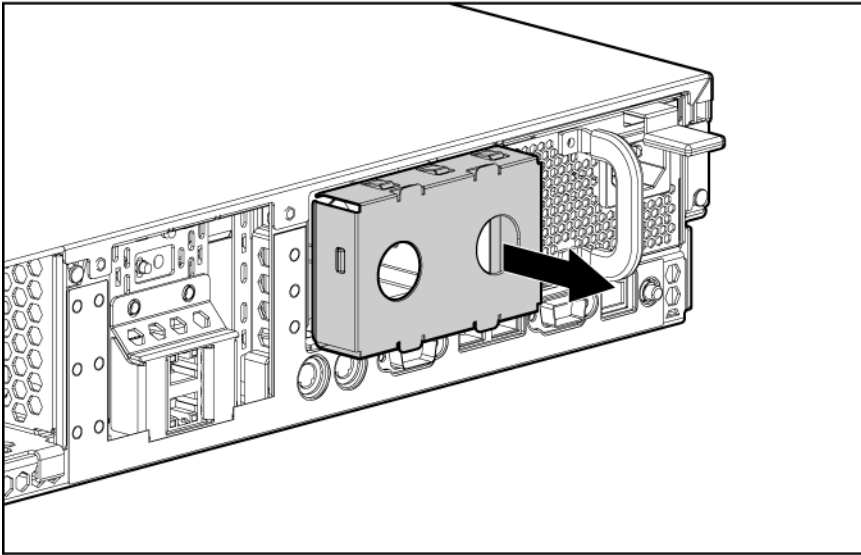

3. Slide the power supply into the power supply bay.

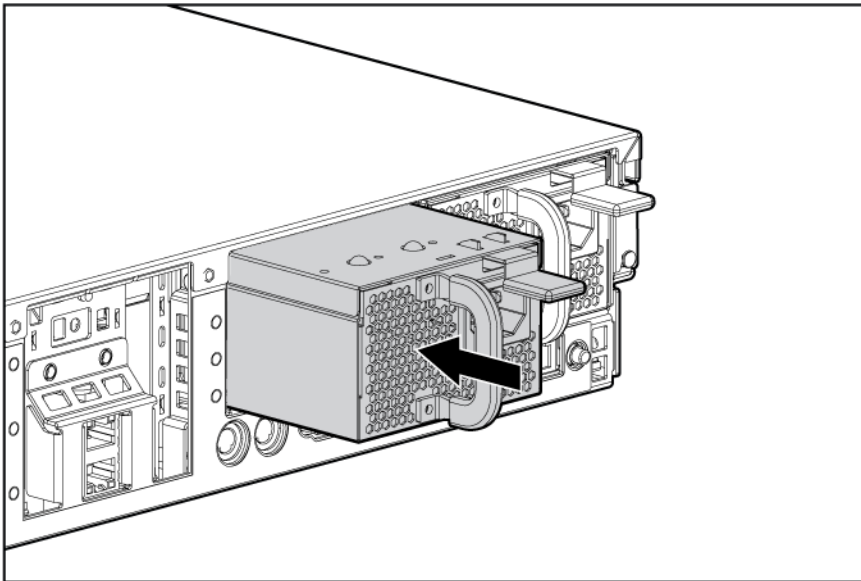

4. Connect the power cord to the power supply.
5. Route the power cord through the power cord anchor or cable management arm.
6. Reposition the cable management arm into the operating position.
7. Connect the power cord to the power source.
8. Be sure that the power supply LED is green ("[Rear panel LEDs and buttons](#)" on page 11).
9. Be sure that the front panel external health LED is green ("[Front panel LEDs and buttons](#)" on page 8).

DC power supply option



WARNING: To reduce the risk of electric shock, fire, and damage to the equipment, this product must be installed in accordance with the following guidelines:

- This power supply is intended only for installation in HP servers located in a restricted access location.
 - This power supply is not intended for direct connection to the DC supply branch circuit. It should only be connected to a power distribution unit (PDU) that provides an independent overcurrent-protected output for each DC power supply. Each output overcurrent-protected device in the PDU must be suitable for interrupting fault current available from the DC power source and must be rated no more than 50A.
 - This power supply is designed to be connected only to a DC power source that can be classified as SELV or TNV, in accordance with applicable national requirements for Information Technology Equipment and Telecommunications Equipment. Generally, these requirements are based on the International Standard for Information Technology Equipment, IEC 60950, and/or the European Telecommunication Standard ETS 300 132-2. The DC source is to have one pole (Neutral/Return) reliably connected to earth ground in accordance with local/regional electric codes and/or regulations.
 - The green/yellow lead of the power cable assembly must be connected to a suitable ground/earth terminal. This terminal must be connected to a suitable building ground/earth terminal in accordance with local/regional electric codes/regulations. Do not rely on the rack or cabinet chassis to provide adequate ground/earth continuity.
-



WARNING: To reduce the risk of personal injury or damage to the equipment, the installation of power supplies should be performed only by individuals who are qualified in servicing server equipment and trained to deal with products capable of producing hazardous energy levels.



WARNING: To reduce the risk of personal injury from hot surfaces, observe the thermal labels on each power supply or module.



WARNING: To reduce the risk of injury from electric shock hazards, do not open power supplies. Refer all maintenance, upgrades, and servicing to qualified personnel.



CAUTION: Do not run the server with one AC power supply and one DC power supply installed.



CAUTION: Electrostatic discharge (ESD) can damage electronic components. Be sure that you are properly grounded (earthed) before beginning any installation procedure.

To install the component:

1. Remove the power supply blank.

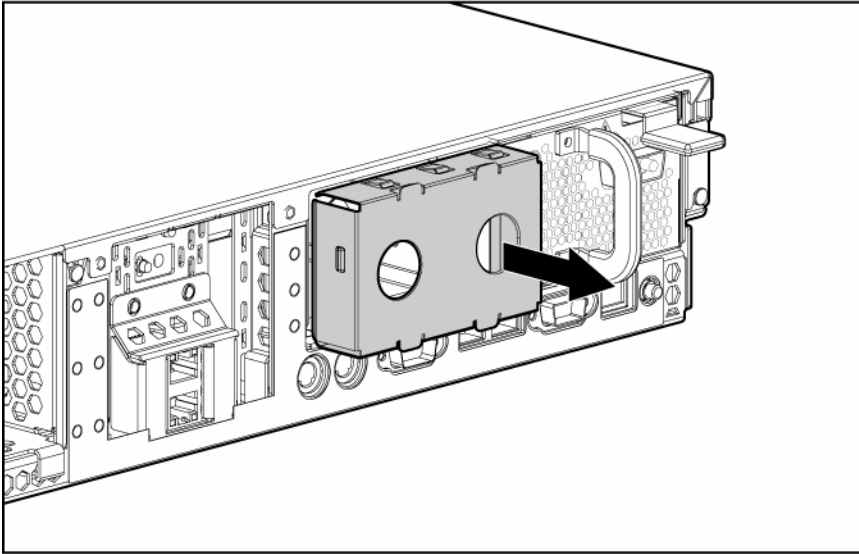

WARNING: To reduce the risk of electric shock or damage to the equipment, do not connect the power cord to the power supply until the power supply is installed.

2. Slide the power supply into the power supply bay until the release/lock lever clicks, securing the power supply.

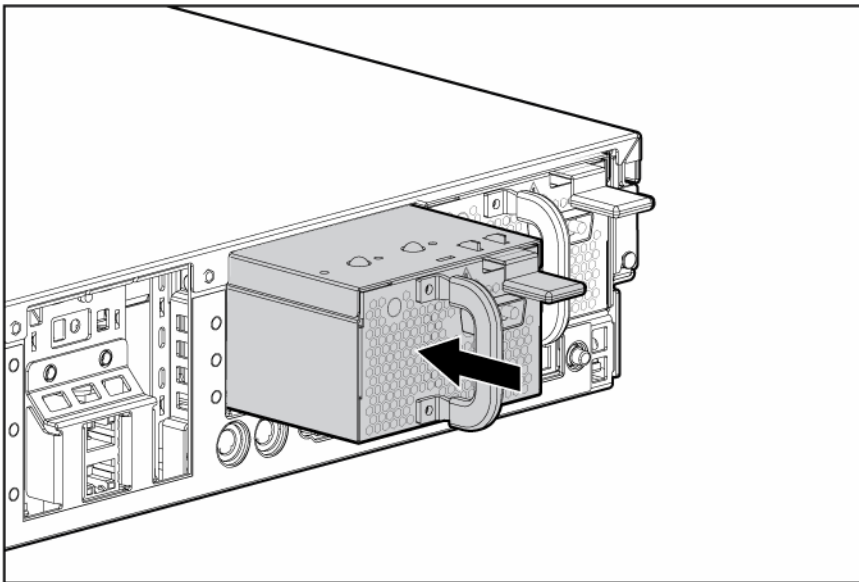

3. Connect the power cord to the power supply.
4. Tighten the two retaining screws on either side of the power cord connector.
5. Route the power cord:
 - o If the cable management arm has a left-hand swing, route the power cord through the cable management arm.
 - o If the cable management arm has a right-hand swing, remove the cable management arm or convert it for left-hand swing. For removal instructions, see "Cable management arm with right-hand swing (on page 29)." For conversion instructions, see the instructions that ship with the 2U Quick Deploy Rail System.

6. Connect the power cord to the DC power source.
7. Be sure that the power supply and external health LEDs are illuminated green.

Expansion board options

The server supports PCI, PCI-X, and PCI Express expansion boards.

Installing an expansion board (slot 2)

1. Power down the server (on page 23).
2. Extend the server from the rack (on page 23).
3. Remove the access panel (on page 24).
4. Remove the expansion slot cover.

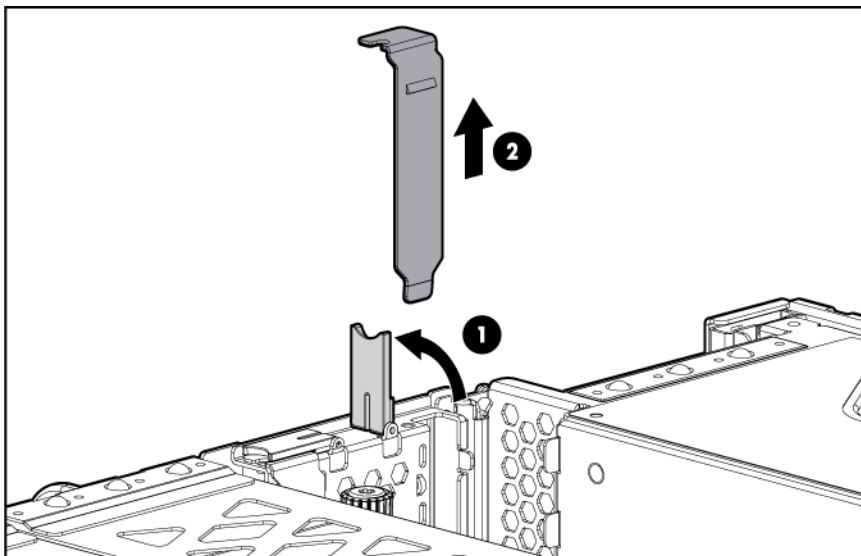

5. Install the expansion board.
6. Connect any required internal or external cables to the expansion board. Refer to the documentation that ships with the expansion board.
7. Install the access panel (on page 25).
8. Install the server into the rack.
9. Power up the server (on page 23).

Removing an expansion slot cover (slot 3, 4, or 5)

CAUTION: To prevent damage to the server or expansion boards, power down the server and remove all AC power cords before removing or installing the PCI riser cage.

CAUTION: To prevent improper cooling and thermal damage, do not operate the server unless all PCI slots have either an expansion slot cover or an expansion board installed.

1. Power down the server (on page 23).
2. Extend the server from the rack (on page 23).

3. Remove the access panel (on page 24).
4. Remove the PCI riser cage (on page 27).
5. Remove the expansion slot cover.

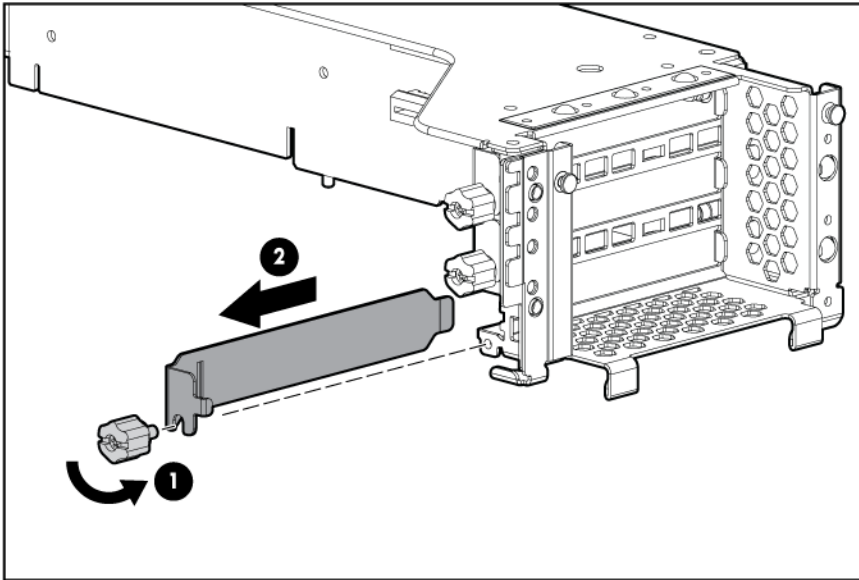

Installing an expansion board (slot 3, 4, or 5)

CAUTION: To prevent damage to the server or expansion boards, power down the server and remove all AC power cords before removing or installing the PCI riser cage.

1. Power down the server (on page 23).
2. Extend the server from the rack (on page 23).
3. Remove the access panel (on page 24).
4. Remove the PCI riser cage (on page 27).
5. Remove the expansion slot cover ("Removing an expansion slot cover (slot 3, 4, or 5)" on page 54).
6. Unlock the PCI retaining clip.

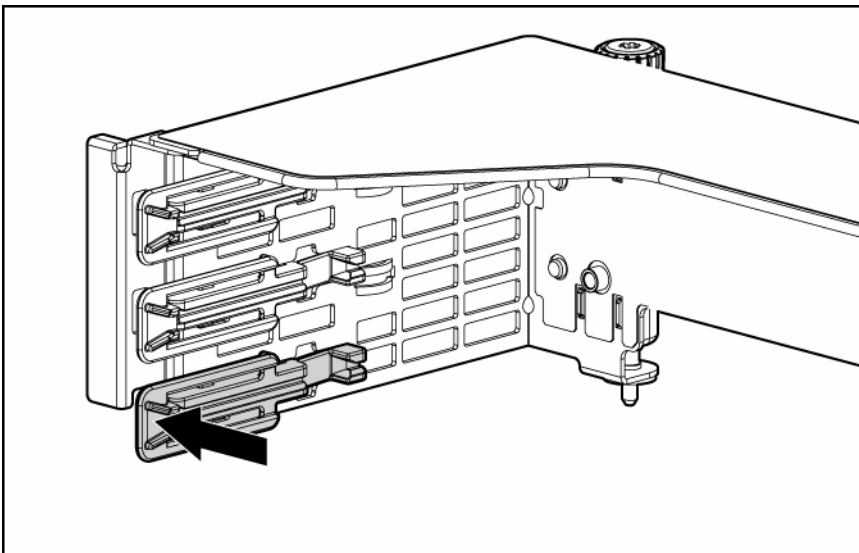

7. Install the expansion board.

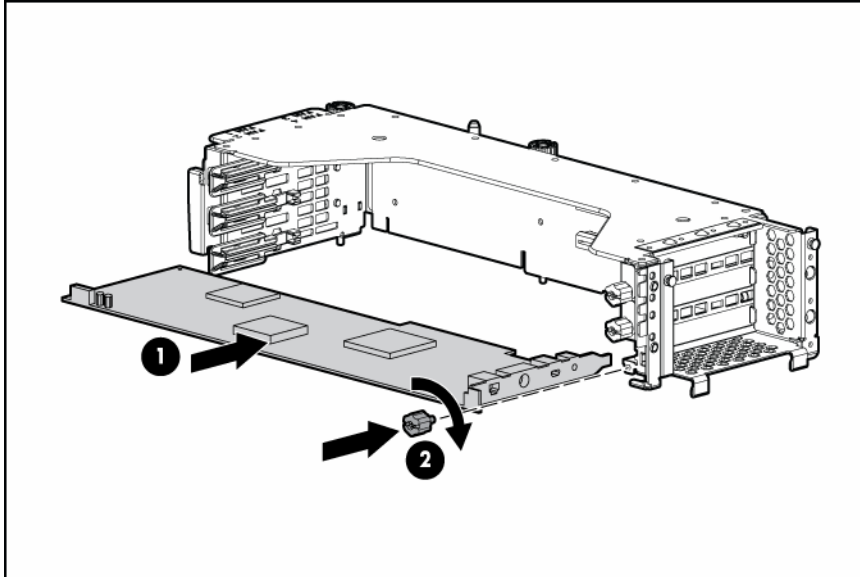

8. Lock the PCI retaining clip.
9. If installing an x16 expansion board that requires a power cable, connect the PCIe x16 riser board power cable to the expansion board and the PCI riser board ("[PCIe x16 riser board power cabling](#)" on page [61](#)).
10. Install the PCI riser cage (on page [27](#)).
11. Connect any required internal or external cables to the expansion board. Refer to the documentation that ships with the expansion board.
12. Install the access panel (on page [25](#)).
13. Install the server into the rack.
14. Power up the server (on page [23](#)).

PCI riser board option

To install the component:

CAUTION: To prevent improper cooling and thermal damage, do not operate the server unless all PCI slots have either an expansion slot cover or an expansion board installed.

1. Power down the server (on page [23](#)).
2. Extend the server from the rack (on page [23](#)).
3. Remove the access panel (on page [24](#)).
4. Remove the PCI riser cage (on page [27](#)).
5. Remove any expansion boards.

6. Remove the PCI riser board.

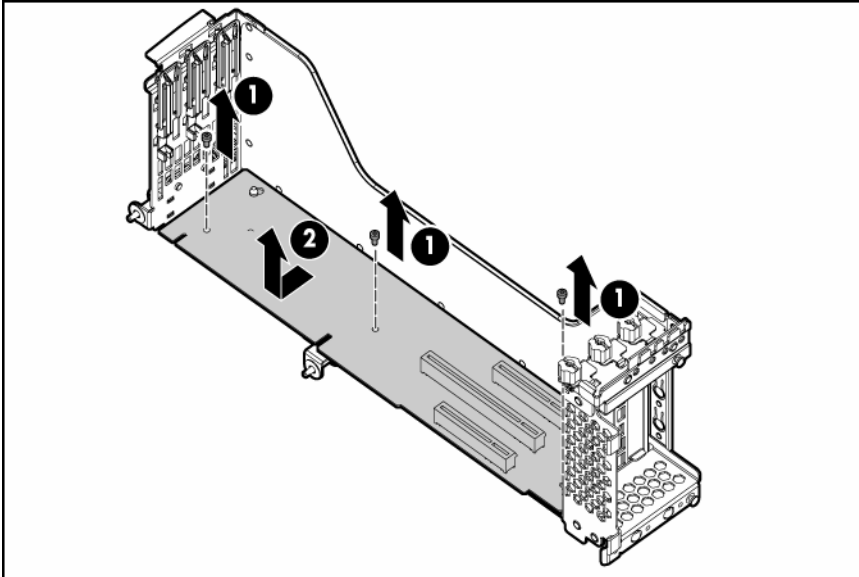

7. Install the optional riser board.
8. Install any expansion boards. ("[Expansion board options](#)" on page 54)
9. Install the PCI riser cage (on page 27).
10. Install the access panel (on page 25).
11. Install the server into the rack.
12. Power up the server (on page 23).

Cabling

SAS hard drive cabling

PCI SAS cabling to an HP Smart Array P400i Controller

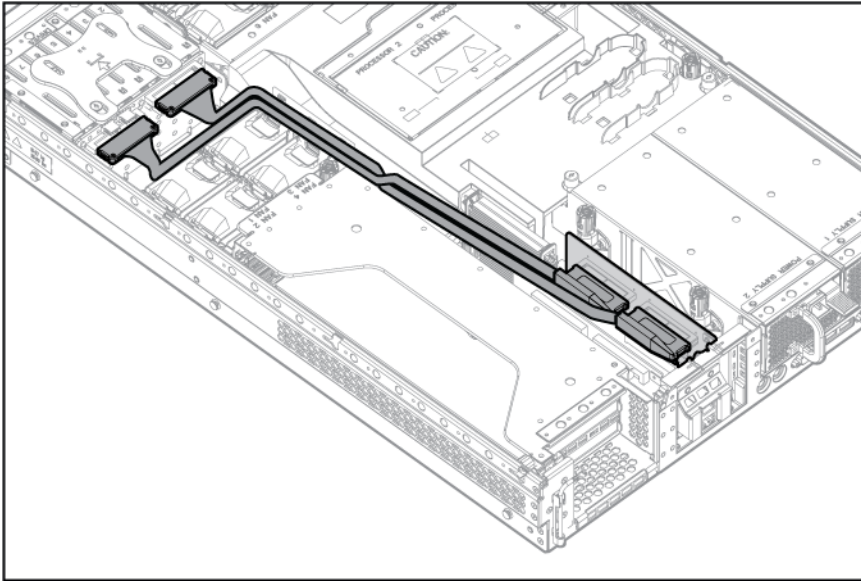

PCI SAS cabling to an optional expansion board controller

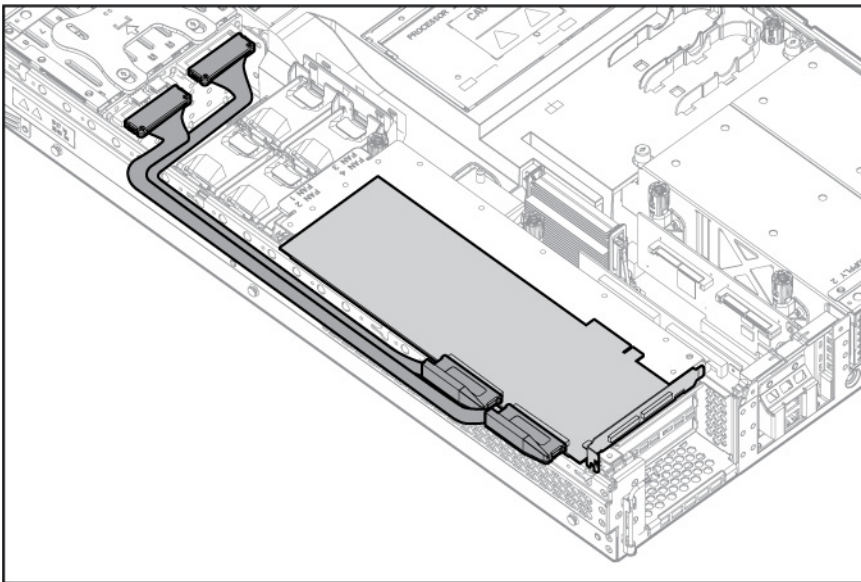

Fan board cabling

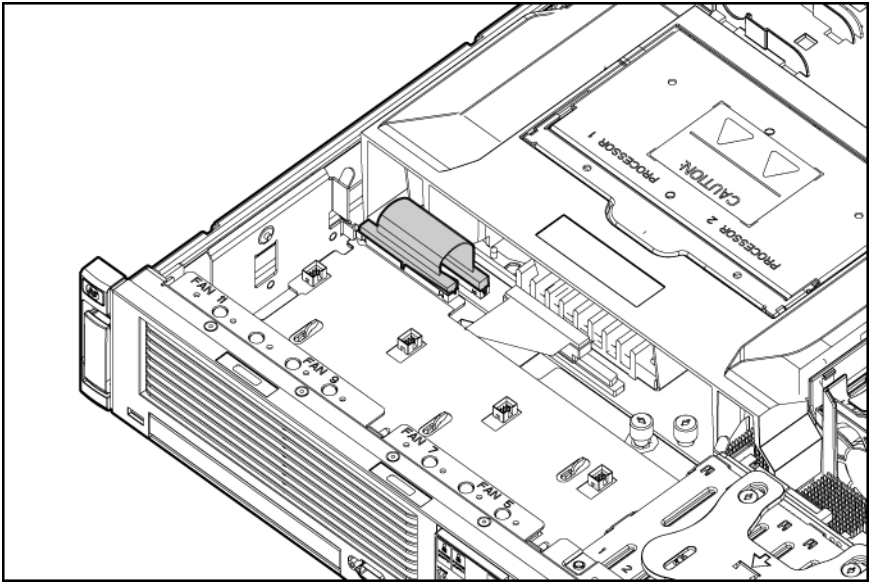

Battery cabling for BBWC

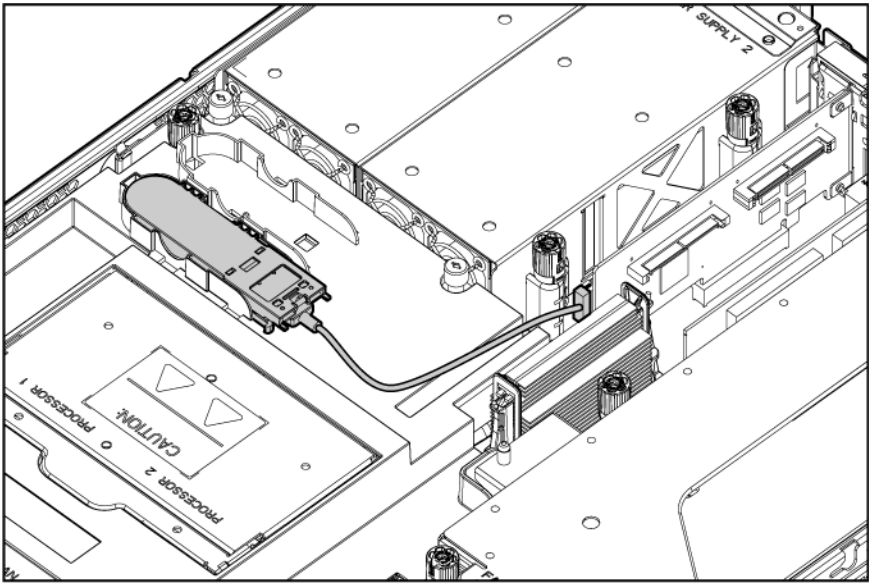

Systems Insight Display cabling

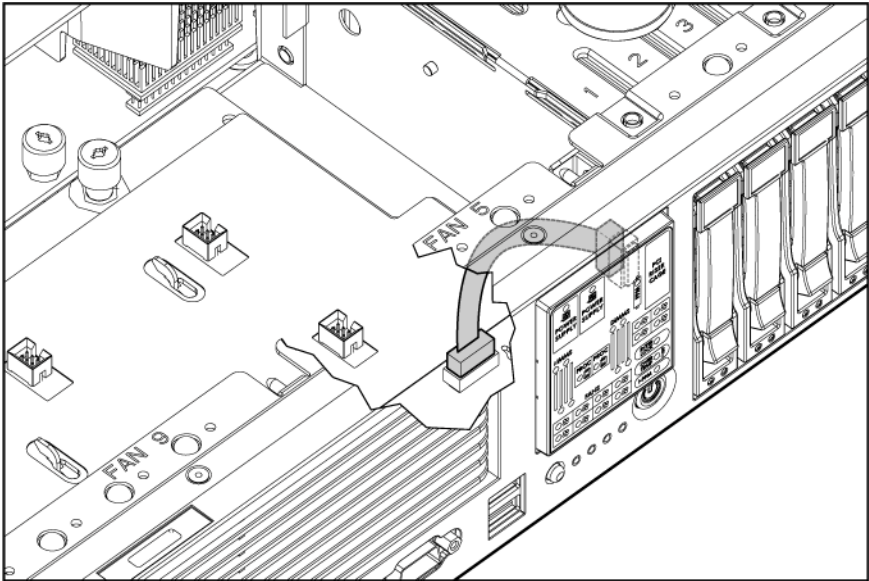

Hard drive backplane power cabling

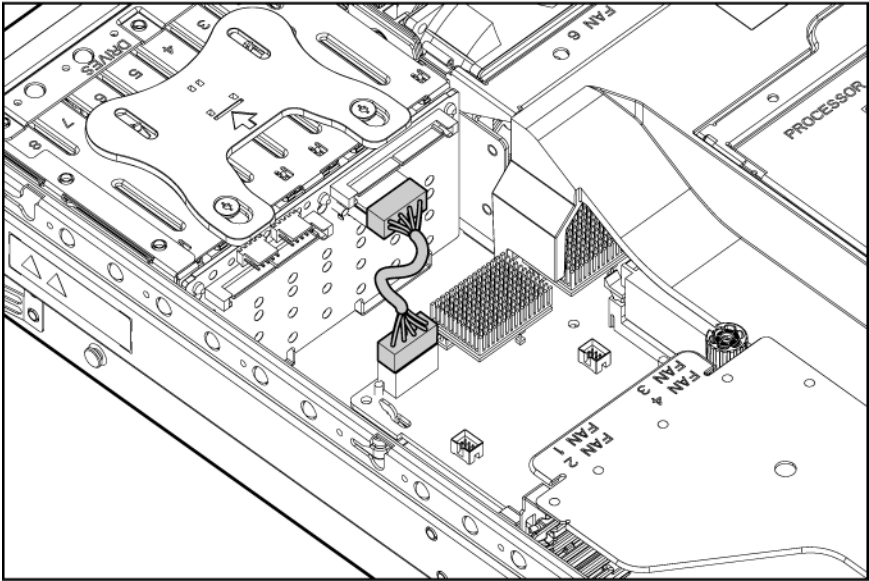

Media drive bay cabling

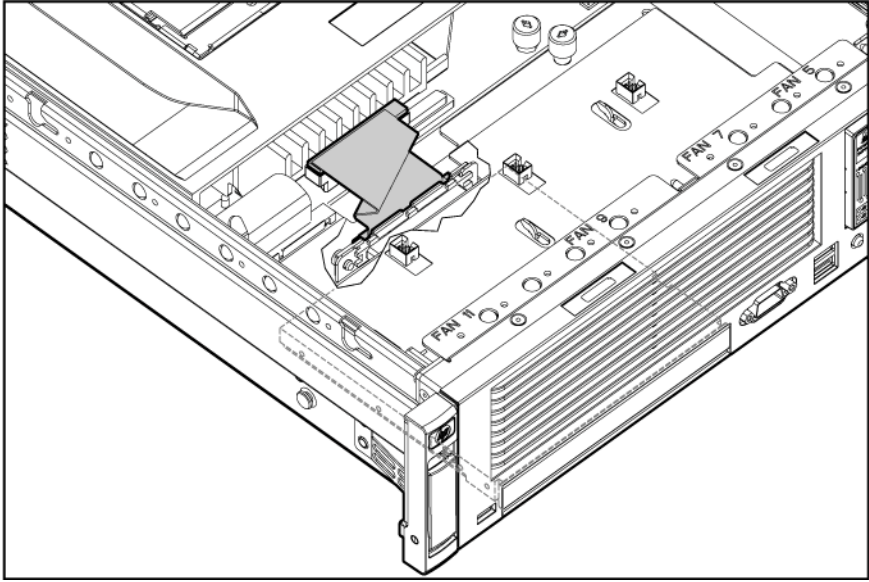

PCIe x16 riser board power cabling

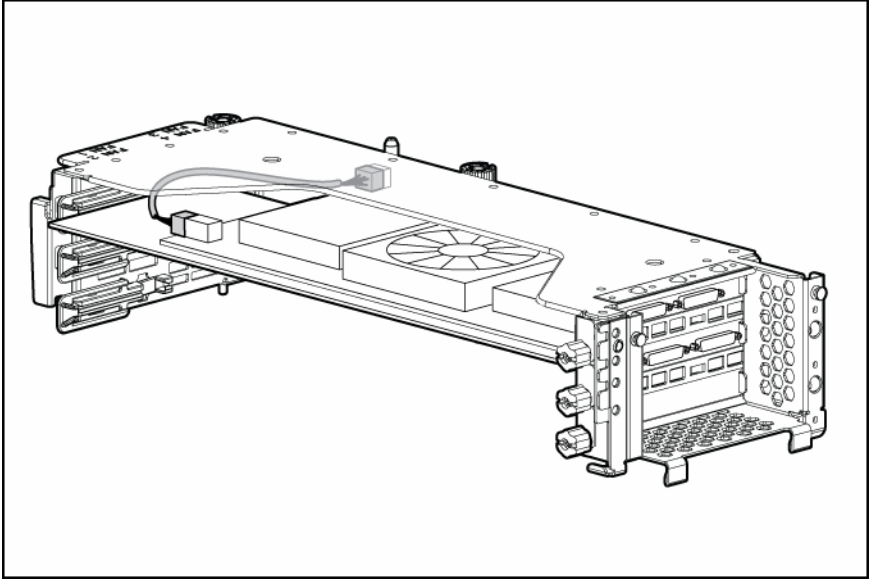

Configuration and utilities

Configuration tools

SmartStart software

SmartStart is a collection of software that optimizes single-server setup, providing a simple and consistent way to deploy server configuration. SmartStart has been tested on many ProLiant server products, resulting in proven, reliable configurations.

SmartStart assists the deployment process by performing a wide range of configuration activities, including:

- Configuring hardware using embedded configuration utilities, such as RBSU and ORCA
- Preparing the system for installing "off-the-shelf" versions of leading operating system software
- Installing optimized server drivers, management agents, and utilities automatically with every assisted installation
- Testing server hardware using the Insight Diagnostics Utility ("HP Insight Diagnostics" on page 70)
- Installing software drivers directly from the CD. With systems that have internet connection, the SmartStart Autorun Menu provides access to a complete list of ProLiant system software.
- Enabling access to the Array Configuration Utility (on page 64), Array Diagnostic Utility (on page 71), and Erase Utility (on page 67)

SmartStart is included in the HP ProLiant Essentials Foundation Pack. For more information about SmartStart software, refer to the HP ProLiant Essentials Foundation Pack or the HP website (<http://h18013.www1.hp.com/products/servers/management/smartstart/index.html>).

SmartStart Scripting Toolkit

The SmartStart Scripting Toolkit is a server deployment product that delivers an unattended automated installation for high-volume server deployments. The SmartStart Scripting Toolkit is designed to support ProLiant BL, ML, and DL servers. The toolkit includes a modular set of utilities and important documentation that describes how to apply these new tools to build an automated server deployment process.

Using SmartStart technology, the Scripting Toolkit provides a flexible way to create standard server configuration scripts. These scripts are used to automate many of the manual steps in the server configuration process. This automated server configuration process cuts time from each server deployed, making it possible to scale server deployments to high volumes in a rapid manner.

For more information, and to download the SmartStart Scripting Toolkit, refer to the HP website (<http://www.hp.com/servers/sstoolkit>).

Configuration Replication Utility

CONREP is shipped in the SmartStart Scripting Toolkit and is a program that works with RBSU to replicate hardware configuration on ProLiant servers. This utility is run during State 0, Run Hardware Configuration Utility, when doing a scripted server deployment. CONREP reads the state of the system environment variables to determine the configuration and then writes the results to an editable script file. This file can then be deployed across multiple servers with similar hardware and software components. For more information, refer to the *SmartStart Scripting Toolkit User Guide* on the HP website (<http://h18004.www1.hp.com/products/servers/management/toolkit/documentation.html>).

HP ROM-Based Setup Utility

RBSU is a configuration utility embedded in ProLiant servers that performs a wide range of configuration activities that can include the following:

- Configuring system devices and installed options
- Enabling and disabling system features
- Displaying system information
- Selecting the primary boot controller
- Configuring memory options
- Language selection

For more information on RBSU, see the *HP ROM-Based Setup Utility User Guide* on the Documentation CD or the HP website (<http://www.hp.com/support/smartstart/documentation>).

Using RBSU

To use RBSU, use the following keys:

- To access RBSU, press the **F9** key during power-up when prompted.
- To navigate the menu system, use the arrow keys.
- To make selections, press the **Enter** key.
- To access Help for a highlighted configuration option, press the **F1** key.



IMPORTANT: RBSU automatically saves settings when you press the **Enter** key. The utility does not prompt you for confirmation of settings before you exit the utility. To change a selected setting, you must select a different setting and press the **Enter** key.

Default configuration settings are applied to the server at one of the following times:

- Upon the first system power-up
- After defaults have been restored

Default configuration settings are sufficient for proper typical server operation, but configuration settings can be modified using RBSU. The system will prompt you for access to RBSU with each power-up.

Auto-configuration process

The auto-configuration process automatically runs when you boot the server for the first time. During the power-up sequence, the system ROM automatically configures the entire system without needing any

intervention. During this process, the ORCA utility, in most cases, automatically configures the array to a default setting based on the number of drives connected to the server.

NOTE: The server may not support all the following examples.

NOTE: If the boot drive is not empty or has been written to in the past, ORCA does not automatically configure the array. You must run ORCA to configure the array settings.

| Drives installed | Drives used | RAID level |
|------------------|---------------|------------|
| 1 | 1 | RAID 0 |
| 2 | 2 | RAID 1 |
| 3, 4, 5, or 6 | 3, 4, 5, or 6 | RAID 5 |
| More than 6 | 0 | None |

To change any ORCA default settings and override the auto-configuration process, press the **F8** key when prompted.

By default, the auto-configuration process configures the system for the English language. To change any default settings in the auto-configuration process (such as the settings for language, operating system, and primary boot controller), execute RBSU by pressing the **F9** key when prompted. After the settings are selected, exit RBSU and allow the server to reboot automatically.

For more information on RBSU, see the *HP ROM-Based Setup Utility User Guide* on the Documentation CD or the HP website (<http://www.hp.com/support/smartstart/documentation>).

Boot options

Near the end of the boot process, the boot options screen is displayed. This screen is visible for several seconds before the system attempts to boot from a diskette, CD, or hard drive. During this time, you can do the following:

- Access RBSU by pressing the **F9** key
- Access the System Maintenance Menu (which enables you to launch ROM-based Diagnostics or Inspect) by pressing the **F10** key
- Force a PXE Network boot by pressing the **F12** key

BIOS Serial Console

BIOS Serial Console allows you to configure the serial port to view POST error messages and run RBSU remotely through a serial connection to the server COM port. The server that you are remotely configuring does not require a keyboard and mouse.

For more information about BIOS Serial Console, see the *BIOS Serial Console User Guide* on the Documentation CD or the HP website (<http://www.hp.com/support/smartstart/documentation>).

Array Configuration Utility

ACU is a browser-based utility with the following features:

- Runs as a local application or remote service

- Supports online array capacity expansion, logical drive extension, assignment of online spares, and RAID or stripe size migration
- Suggests the optimum configuration for an unconfigured system
- Provides different operating modes, enabling faster configuration or greater control over the configuration options
- Remains available any time that the server is on
- Displays on-screen tips for individual steps of a configuration procedure

For optimum performance, the minimum display settings are 800 × 600 resolution and 256 colors. Servers running Microsoft® operating systems require Internet Explorer 5.5 (with Service Pack 1) or later. For Linux servers, refer to the README.TXT file for additional browser and support information.

For more information, refer to the *Configuring Arrays on HP Smart Array Controllers Reference Guide* on the Documentation CD or the HP website (<http://www.hp.com>).

Option ROM Configuration for Arrays

Before installing an operating system, you can use the ORCA utility to create the first logical drive, assign RAID levels, and establish online spare configurations.

The utility also provides support for the following functions:

- Reconfiguring one or more logical drives
- Viewing the current logical drive configuration
- Deleting a logical drive configuration
- Setting the controller to be the boot controller

If you do not use the utility, ORCA will default to the standard configuration.

For more information regarding array controller configuration, refer to the controller user guide.

For more information regarding the default configurations that ORCA uses, refer to the *HP ROM-Based Setup Utility User Guide* on the Documentation CD.

HP ProLiant Essentials Rapid Deployment Pack

The RDP software is the preferred method for rapid, high-volume server deployments. The RDP software integrates two powerful products: Altiris Deployment Solution and the HP ProLiant Integration Module.

The intuitive graphical user interface of the Altiris Deployment Solution console provides simplified point-and-click and drag-and-drop operations that enable you to deploy target servers, including server blades, remotely. It enables you to perform imaging or scripting functions and maintain software images.

For more information about the RDP, refer to the HP ProLiant Essentials Rapid Deployment Pack CD or refer to the HP website (<http://www.hp.com/servers/rdp>).

Re-entering the server serial number and product ID

After you replace the system board, you must re-enter the server serial number and the product ID.

1. During the server startup sequence, press the **F9** key to access RBSU.
2. Select the **System Options** menu.

3. Select **Serial Number**. The following warning is displayed:
WARNING! WARNING! WARNING! The serial number is loaded into the system during the manufacturing process and should NOT be modified. This option should only be used by qualified service personnel. This value should always match the serial number sticker located on the chassis.
4. Press the **Enter** key to clear the warning.
5. Enter the serial number and press the **Enter** key.
6. Select **Product ID**.
7. Enter the product ID and press the **Enter** key.
8. Press the **Esc** key to close the menu.
9. Press the **Esc** key to exit RBSU.
10. Press the **F10** key to confirm exiting RBSU. The server will automatically reboot.

Management tools

Automatic Server Recovery

ASR is a feature that causes the system to restart when a catastrophic operating system error occurs, such as a blue screen, ABEND, or panic. A system fail-safe timer, the ASR timer, starts when the System Management driver, also known as the Health Driver, is loaded. When the operating system is functioning properly, the system periodically resets the timer. However, when the operating system fails, the timer expires and restarts the server.

ASR increases server availability by restarting the server within a specified time after a system hang or shutdown. At the same time, the HP SIM console notifies you by sending a message to a designated pager number that ASR has restarted the system. You can disable ASR from the HP SIM console or through RBSU.

ROMPaq utility

The ROMPaq utility enables you to upgrade the system firmware (BIOS) or Lights-Out 100 firmware. To upgrade the firmware, insert a ROMPaq diskette into the diskette drive or ROMPaq USB Key into an available USB port and boot the system.

The ROMPaq utility checks the system and provides a choice (if more than one exists) of available firmware revisions.

For more information about the ROMPaq utility, see the HP website (<http://www.hp.com/go/support>).

System Online ROM flash component utility

The Online ROM Flash Component Utility enables system administrators to efficiently upgrade system or controller ROM images across a wide range of servers and array controllers. This tool has the following features:

- Works offline and online
- Supports Microsoft® Windows NT®, Windows® 2000, Windows Server™ 2003, Novell Netware, and Linux operating systems



IMPORTANT: This utility supports operating systems that may not be supported by the server. For operating systems supported by the server, see the HP website (<http://www.hp.com/support>).

- Integrates with other software maintenance, deployment, and operating system tools
- Automatically checks for hardware, firmware, and operating system dependencies, and installs only the correct ROM upgrades required by each target server

To download the tool and for more information, see the HP website (<http://www.hp.com/support>).

Integrated Lights-Out 2 technology

The iLO 2 subsystem is a standard component of selected ProLiant servers that provides server health and remote server manageability. The iLO 2 subsystem includes an intelligent microprocessor, secure memory, and a dedicated network interface. This design makes iLO 2 independent of the host server and its operating system. The iLO 2 subsystem provides remote access to any authorized network client, sends alerts, and provides other server management functions.

Using iLO 2, you can:

- Remotely power up, power down, or reboot the host server.
- Send alerts from iLO 2 regardless of the state of the host server.
- Access advanced troubleshooting features through the iLO 2 interface.
- Diagnose iLO 2 using HP SIM through a web browser and SNMP alerting.

For more information about iLO 2 features, refer to the iLO 2 documentation on the Documentation CD or on the HP website (<http://www.hp.com/servers/lights-out>).

Erase Utility



CAUTION: Perform a backup before running the System Erase Utility. The utility sets the system to its original factory state, deletes the current hardware configuration information, including array setup and disk partitioning, and erases all connected hard drives completely. Refer to the instructions for using this utility.

Run the Erase Utility if you must erase the system for the following reasons:

- You want to install a new operating system on a server with an existing operating system.
- You encounter an error when completing the steps of a factory-installed operating system installation.

The Erase Utility can be accessed from the **Maintenance Utilities** menu of the SmartStart CD ("SmartStart software" on page 62).

StorageWorks library and tape tools

HP StorageWorks L&TT provides functionality for firmware downloads, verification of device operation, maintenance procedures, failure analysis, corrective service actions, and some utility functions. It also provides seamless integration with HP hardware support by generating and emailing support tickets that deliver a snapshot of the storage system.

For more information, and to download the utility, refer to the StorageWorks L&TT website (<http://h18006.www1.hp.com/products/storageworks/ltt>).

HP Systems Insight Manager

HP SIM is a web-based application that allows system administrators to accomplish normal administrative tasks from any remote location, using a web browser. HP SIM provides device management capabilities that consolidate and integrate management data from HP and third-party devices.



IMPORTANT: You must install and use HP SIM to benefit from the Pre-Failure Warranty for processors, SAS and SCSI hard drives, and memory modules.

For additional information, refer to the Management CD in the HP ProLiant Essentials Foundation Pack or the HP SIM website (<http://www.hp.com/go/hpsim>).

Management Agents

Management Agents provide the information to enable fault, performance, and configuration management. The agents allow easy manageability of the server through HP SIM software, and third-party SNMP management platforms. Management Agents are installed with every SmartStart assisted installation or can be installed through the HP PSP. The Systems Management homepage provides status and direct access to in-depth subsystem information by accessing data reported through the Management Agents. For additional information, refer to the Management CD in the HP ProLiant Essentials Foundation Pack or the HP website (<http://www.hp.com/servers/manage>).

Redundant ROM support

The server enables you to upgrade or configure the ROM safely with redundant ROM support. The server has a 4-MB ROM that acts as two, separate 2-MB ROMs. In the standard implementation, one side of the ROM contains the current ROM program version, while the other side of the ROM contains a backup version.

NOTE: The server ships with the same version programmed on each side of the ROM.

Safety and security benefits

When you flash the system ROM, ROMPaq writes over the backup ROM and saves the current ROM as a backup, enabling you to switch easily to the alternate ROM version if the new ROM becomes corrupted for any reason. This feature protects the existing ROM version, even if you experience a power failure while flashing the ROM.

Access to redundant ROM settings

To access the redundant ROM through RBSU:

1. Access RBSU by pressing the **F9** key during powerup when the prompt is displayed in the upper right corner of the screen.
2. Select **Advanced Options**.
3. Select **Redundant ROM Selection**.

4. Select the ROM version.
5. Press the **Enter** key.
6. Press the **Esc** key to exit the current menu or press the **F10** key to exit RBSU. The server restarts automatically.

To access the redundant ROM manually:

1. Power down the server (on page 23).
2. Remove the access panel (on page 24).
3. Set positions 1, 5, and 6 of the system maintenance switch to On.
4. Install the access panel (on page 25).
5. Power up the server (on page 23).
6. Wait for the server to emit two beeps.
7. Repeat steps 1 and 2.
8. Set positions 1, 5, and 6 of the system maintenance switch to Off.
9. Repeat steps 4 and 5.

When the server boots, the system identifies whether the current ROM bank is corrupt. If a corrupt ROM is detected, the system boots from the backup ROM and alerts you through POST or IML that the ROM bank is corrupt.

If both the current and backup versions of the ROM are corrupt, the server automatically enters ROMPaq disaster recovery mode.

USB support

HP provides both standard USB support and legacy USB support. Standard support is provided by the operating system through the appropriate USB device drivers. HP provides support for USB devices prior to the operating system loading through legacy USB support, which is enabled by default in the system ROM. HP hardware supports USB version 2.0.

Legacy USB support provides USB functionality in environments where USB support is normally not available. Specifically, HP provides legacy USB functionality at:

- POST
- RBSU
- Diagnostics
- DOS
- Environments which do not support USB natively

For more information on ProLiant USB support, refer to the HP website (<http://www.compaq.com/products/servers/platforms/usb-support.html>).

Changing the USB version support

The factory default setting for this server is USB version 1.1. After the OS has loaded, this setting can be changed to USB version 2.0 using the following steps:

1. Access RBSU by pressing **F9** during power up.
2. Select **System Options**.

3. Select **USB External Port Capability**.
4. Press **Enter** to display USB 1.1 and USB 2.0 selections.
5. Arrow down to highlight USB 2.0.
6. Press **Enter**.
7. Press **F10** to save the change and exit RBSU.

Internal USB functionality

An internal USB connector is available for use with USB drive keys only. This solution provides for use of a permanent boot drive from a USB drive key installed in the internal connector, avoiding issues of clearance on the front of the rack and physical access to secure data.

For additional security, you can disable the external USB connectors through RBSU. Disabling the rear USB connectors in RBSU disables both rear USB ports.

Diagnostic tools

HP Insight Diagnostics

HP Insight Diagnostics is a proactive server management tool, available in both offline and online versions, that provides diagnostics and troubleshooting capabilities to assist IT administrators who verify server installations, troubleshoot problems, and perform repair validation.

HP Insight Diagnostics Offline Edition performs various in-depth system and component testing while the OS is not running. To run this utility, launch the SmartStart CD.

HP Insight Diagnostics Online Edition is a web-based application that captures system configuration and other related data needed for effective server management. Available in Microsoft® Windows® and Linux versions, the utility helps to ensure proper system operation.

For more information or to download the utility, refer to the HP website (<http://www.hp.com/servers/diags>).

HP Insight Diagnostics survey functionality

HP Insight Diagnostics (on page 70) provides survey functionality that gathers critical hardware and software information on ProLiant servers.

This functionality supports operating systems that may not be supported by the server. For operating systems supported by the server, see the HP website (<http://www.hp.com/go/supportos>).

If a significant change occurs between data-gathering intervals, the survey function marks the previous information and overwrites the survey data files to reflect the latest changes in the configuration.

Survey functionality is installed with every SmartStart-assisted HP Insight Diagnostics installation, or it can be installed through the HP PSP ("ProLiant Support Packs" on page 72).

NOTE: The current version of SmartStart provides the memory spare part numbers for the server. To download the latest version, see the HP website (<http://www.hp.com/support>).

Integrated Management Log

The IML records hundreds of events and stores them in an easy-to-view form. The IML timestamps each event with 1-minute granularity.

You can view recorded events in the IML in several ways, including the following:

- From within HP SIM ("HP Systems Insight Manager" on page 68)
- From within Survey Utility
- From within operating system-specific IML viewers
 - For NetWare: IML Viewer
 - For Windows®: IML Viewer
 - For Linux: IML Viewer Application
- From within the iLO 2 user interface
- From within HP Insight Diagnostics (on page 70)

For more information, refer to the Management CD in the HP ProLiant Essentials Foundation Pack.

Array Diagnostic Utility

The HP Array Diagnostics Utility is a web-based application that creates a report of all HP storage controllers and disk drives. This report provides vital information to assist in identifying faults or conditions that may require attention. ADU can be accessed from the SmartStart CD ("SmartStart software" on page 62) or downloaded from the HP website (<http://www.hp.com>).

Remote support and analysis tools

HP Instant Support Enterprise Edition

ISEE is a proactive remote monitoring and diagnostic tool to help manage your systems and devices, a feature of HP support. ISEE provides continuous hardware event monitoring and automated notification to identify and prevent potential critical problems. Through remote diagnostic scripts and vital system configuration information collected about your systems, ISEE enables fast restoration of your systems. Install ISEE on your systems to help mitigate risk and prevent potential critical problems.

For more information on ISEE, refer to the HP website (http://www.hp.com/hps/hardware/hw_enterprise.html).

To download HP ISEE, visit the HP website (http://www.hp.com/hps/hardware/hw_downloads.html).

For installation information, refer to the HP ISEE Client Installation and Upgrade Guide (ftp://ftp.hp.com/pub/services/hardware/info/isee_client.pdf).

Web-Based Enterprise Service

WEBES enables administrators to manage hardware events proactively, either locally or online. The service provides real-time multiple event analysis, crash analysis, and notification, locally through SMTP and remotely through ISEE for OpenVMS, Tru64, and Microsoft® Windows® operating system binary error logs.

For more information, refer to the HP website (<http://h18000.www1.hp.com/support/svctools/>).

Open Services Event Manager

OSEM is a standalone tool that performs real-time reactive and proactive service event filtering, analysis, and notification. The tool gathers event data from SNMP traps or information provided over an HTTP interface and notifies an administrator or HP through SMTP and ISEE.

For more information, refer to the HP website (<http://h18000.www1.hp.com/support/svctools/>).

Keeping the system current

Drivers

The server includes new hardware that may not have driver support on all operating system installation media.

If you are installing a SmartStart-supported operating system, use the SmartStart software (on page 62) and its Assisted Path feature to install the operating system and latest driver support.

NOTE: If you are installing drivers from the SmartStart CD or the Software Maintenance CD, refer to the SmartStart website (<http://www.hp.com/servers/smartstart>) to be sure that you are using the latest version of SmartStart. For more information, refer to the documentation provided with the SmartStart CD.

If you do not use the SmartStart CD to install an operating system, drivers for some of the new hardware are required. These drivers, as well as other option drivers, ROM images, and value-add software can be downloaded from the HP website (<http://www.hp.com/support>).



IMPORTANT: Always perform a backup before installing or updating device drivers.

ProLiant Support Packs

PSPs represent operating system-specific bundles of ProLiant optimized drivers, utilities, and management agents. Refer to the PSP website (<http://h18000.www1.hp.com/products/servers/management/psp.html>).

Operating system version support

Refer to the operating system support matrix (<http://www.hp.com/go/supportos>).

Change control and proactive notification

HP offers Change Control and Proactive Notification to notify customers 30 to 60 days in advance of upcoming hardware and software changes on HP commercial products.

For more information, refer to the HP website (<http://www.hp.com/go/pcn>).

Care Pack

HP Care Pack Services offer upgraded service levels to extend and expand standard product warranty with easy-to-buy, easy-to-use support packages that help you make the most of your server investments. Refer to the Care Pack website (http://www.hp.com/hps/carepack/servers/cp_proliant.html).

Troubleshooting

Troubleshooting resources

The *HP ProLiant Servers Troubleshooting Guide* provides simple procedures for resolving common problems as well as a comprehensive course of action for fault isolation and identification, error message interpretation, issue resolution, and software maintenance.

To obtain the guide, refer to any of the following sources and then select the *HP ProLiant Servers Troubleshooting Guide*:

- The server-specific Documentation CD
- The Business Support Center on the HP website (<http://www.hp.com/support>). Navigate to the server technical support page. Under self-help resources, select **ProLiant Troubleshooting Guide**.
- The Technical Documentation website (<http://www.docs.hp.com>). Select **Enterprise Servers, Workstations and Systems Hardware**, and then the appropriate server.

Pre-diagnostic steps



WARNING: To avoid potential problems, ALWAYS read the warnings and cautionary information in the server documentation before removing, replacing, reseating, or modifying system components



IMPORTANT: This guide provides information for multiple servers. Some information may not apply to the server you are troubleshooting. Refer to the server documentation for information on procedures, hardware options, software tools, and operating systems supported by the server.

1. Review the important safety information (on page [74](#)).
2. Gather symptom information (on page [76](#)).
3. Prepare the server for diagnosis (on page [77](#)).
4. Use the Start diagnosis flowchart (on page [78](#)) to begin the diagnostic process.

Important safety information

Familiarize yourself with the safety information in the following sections before troubleshooting the server.



Important safety information

Before servicing this product, read the *Important Safety Information* document provided with the server.

Symbols on equipment

The following symbols may be placed on equipment to indicate the presence of potentially hazardous conditions.



This symbol indicates the presence of hazardous energy circuits or electric shock hazards. Refer all servicing to qualified personnel.

WARNING: To reduce the risk of injury from electric shock hazards, do not open this enclosure. Refer all maintenance, upgrades, and servicing to qualified personnel.



This symbol indicates the presence of electric shock hazards. The area contains no user or field serviceable parts. Do not open for any reason.

WARNING: To reduce the risk of injury from electric shock hazards, do not open this enclosure.



This symbol on an RJ-45 receptacle indicates a network interface connection.

WARNING: To reduce the risk of electric shock, fire, or damage to the equipment, do not plug telephone or telecommunications connectors into this receptacle.



This symbol indicates the presence of a hot surface or hot component. If this surface is contacted, the potential for injury exists.

WARNING: To reduce the risk of injury from a hot component, allow the surface to cool before touching.



20.41 - 27.22 kg
47.18 - 60.0 lb

This symbol indicates that the component exceeds the recommended weight for one individual to handle safely.

WARNING: To reduce the risk of personal injury or damage to the equipment, observe local occupational health and safety requirements and guidelines for manual material handling.



These symbols, on power supplies or systems, indicate that the equipment is supplied by multiple sources of power.

WARNING: To reduce the risk of injury from electric shock, remove all power cords to completely disconnect power from the system.

Warnings and cautions



WARNING: Only authorized technicians trained by HP should attempt to repair this equipment. All troubleshooting and repair procedures are detailed to allow only subassembly/module-level repair. Because of the complexity of the individual boards and subassemblies, no one should attempt to make repairs at the component level or to make modifications to any printed wiring board. Improper repairs can create a safety hazard.



WARNING: To reduce the risk of personal injury or damage to the equipment, be sure that:

- The leveling feet are extended to the floor.
- The full weight of the rack rests on the leveling feet.
- The stabilizing feet are attached to the rack if it is a single-rack installation.
- The racks are coupled together in multiple-rack installations.
- Only one component is extended at a time. A rack may become unstable if more than one component is extended for any reason.



WARNING: To reduce the risk of electric shock or damage to the equipment:

- Do not disable the power cord grounding plug. The grounding plug is an important safety feature.
- Plug the power cord into a grounded (earthed) electrical outlet that is easily accessible at all times.
- Unplug the power cord from the power supply to disconnect power to the equipment.
- Do not route the power cord where it can be walked on or pinched by items placed against it. Pay particular attention to the plug, electrical outlet, and the point where the cord extends from the server.



20.41 - 27.22 kg

47.18 - 60.0 lb

WARNING: To reduce the risk of personal injury or damage to the equipment:

- Observe local occupation health and safety requirements and guidelines for manual handling.
- Obtain adequate assistance to lift and stabilize the chassis during installation or removal.
- The server is unstable when not fastened to the rails.
- When mounting the server in a rack, remove the power supplies and any other removable module to reduce the overall weight of the product.



CAUTION: To properly ventilate the system, you must provide at least 7.6 cm (3.0 in) of clearance at the front and back of the server.



CAUTION: The server is designed to be electrically grounded (earthed). To ensure proper operation, plug the AC power cord into a properly grounded AC outlet only.

Symptom information

Before troubleshooting a server problem, collect the following information:

- What events preceded the failure? After which steps does the problem occur?
- What has been changed since the time the server was working?
- Did you recently add or remove hardware or software? If so, did you remember to change the appropriate settings in the server setup utility, if necessary?
- How long has the server exhibited problem symptoms?
- If the problem occurs randomly, what is the duration or frequency?

To answer these questions, the following information may be useful:

- Run HP Insight Diagnostics (on page 70) and use the survey page to view the current configuration or to compare it to previous configurations.
- Refer to your hardware and software records for information.
- Refer to server LEDs and their statuses.

Prepare the server for diagnosis

1. Be sure the server is in the proper operating environment with adequate power, air conditioning, and humidity control. Refer to the server documentation for required environmental conditions.
2. Record any error messages displayed by the system.
3. Remove all diskettes and CDs from the media drives.
4. Power down the server and peripheral devices if you will be diagnosing the server offline. Always perform an orderly shutdown, if possible. This means you must:
 - a. Exit any applications.
 - b. Exit the operating system.
 - c. Power down the server (on page 23).
5. Disconnect any peripheral devices not required for testing (any devices not necessary to power up the server). Do not disconnect the printer if you want to use it to print error messages.
6. Collect all tools and utilities, such as a Torx screwdriver, loopback adapters, ESD wrist strap, and software utilities, necessary to troubleshoot the problem.
 - You must have the appropriate Health Drivers and Management Agents installed on the server.

NOTE: To verify the server configuration, connect to the System Management homepage and select **Version Control Agent**. The VCA gives you a list of names and versions of all installed HP drivers, Management Agents, and utilities, and whether they are up to date.

- HP recommends you have access to the SmartStart CD for value-added software and drivers required during the troubleshooting process.
- HP recommends you have access to the server documentation for server-specific information.

Loose connections

Action:

- Be sure all power cords are securely connected.
- Be sure all cables are properly aligned and securely connected for all external and internal components.
- Remove and check all data and power cables for damage. Be sure no cables have bent pins or damaged connectors.
- If a fixed cable tray is available for the server, be sure the cords and cables connected to the server are routed correctly through the tray.
- Be sure each device is properly seated. Avoid bending or flexing circuit boards when reseating components.
- If a device has latches, be sure they are completely closed and locked.

- Check any interlock or interconnect LEDs that may indicate a component is not connected properly.
- If problems continue to occur, remove and reinstall each device, checking the connectors and sockets for bent pins or other damage.

Service notifications

To view the latest service notifications, refer to the HP website (<http://www.hp.com/go/bizsupport>). Select the appropriate server model, and then click the **Troubleshoot a Problem** link on the product page.

Troubleshooting flowcharts

To effectively troubleshoot a problem, HP recommends that you start with the first flowchart in this section, "Start diagnosis flowchart (on page 78)," and follow the appropriate diagnostic path. If the other flowcharts do not provide a troubleshooting solution, follow the diagnostic steps in "General diagnosis flowchart (on page 79)." The General diagnosis flowchart is a generic troubleshooting process to be used when the problem is not server-specific or is not easily categorized into the other flowcharts.

The available flowcharts include:

- Start diagnosis flowchart (on page 78)
- General diagnosis flowchart (on page 79)
- Server power-on problems flowchart (on page 81)
- POST problems flowchart (on page 84)
- OS boot problems flowchart (on page 85)
- Server fault indications flowchart (on page 87)

Start diagnosis flowchart

Use the following flowchart to start the diagnostic process.

| Item | Refer to |
|------|---|
| 1 | "General diagnosis flowchart (on page 79)" |
| 2 | "Power-on problems flowchart ("Server power-on problems flowchart" on page 81)" |
| 3 | "POST problems flowchart (on page 84)" |
| 4 | "OS boot problems flowchart (on page 85)" |
| 5 | "Server fault indications flowchart (on page 87)" |

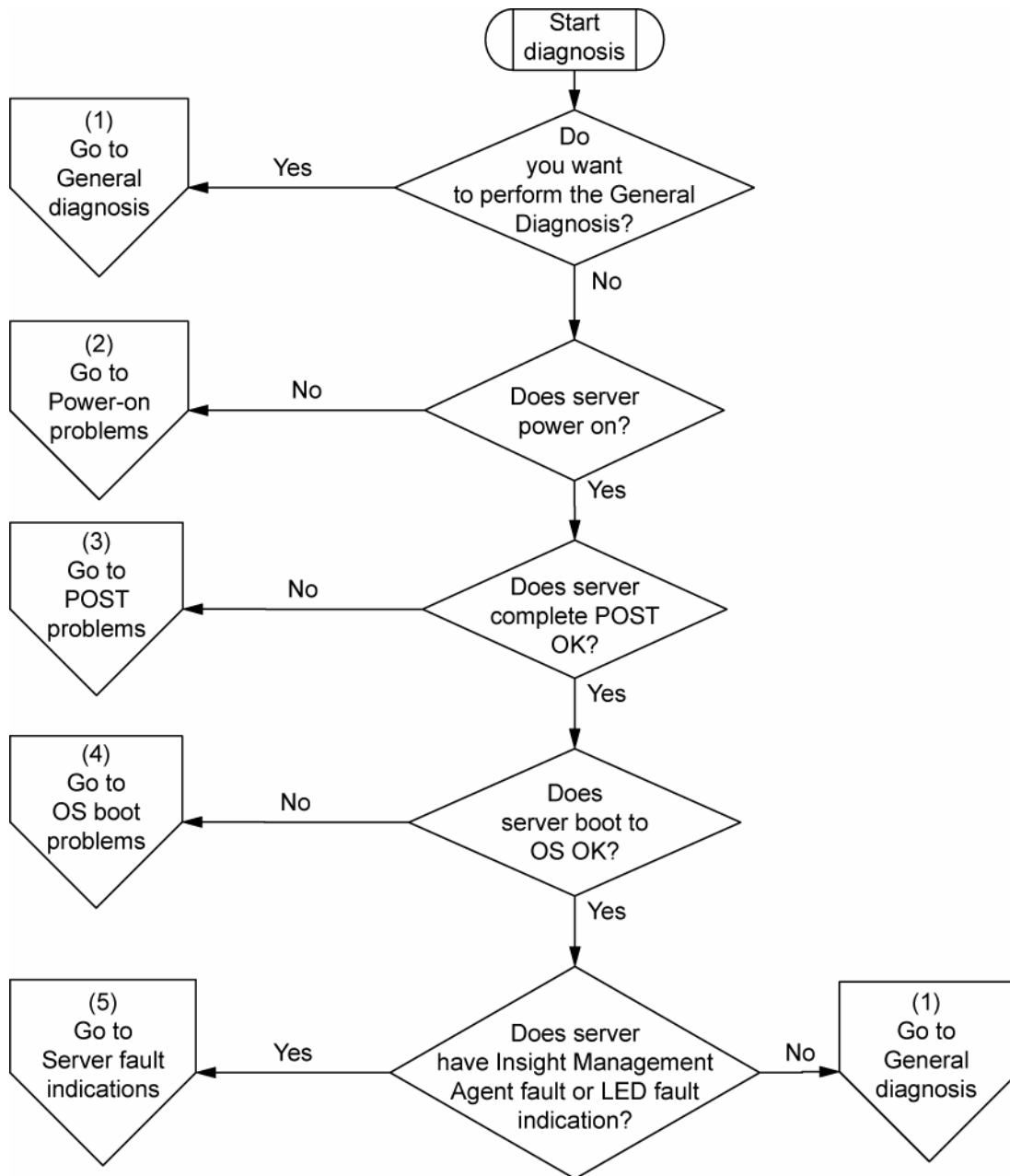

General diagnosis flowchart

The General diagnosis flowchart provides a generic approach to troubleshooting. If you are unsure of the problem, or if the other flowcharts do not fix the problem, use the following flowchart.

| Item | Refer to |
|------|--------------------------------------|
| 1 | "Symptom information (on page 76)" |
| 2 | "Loose connections (on page 77)" |
| 3 | "Service notifications (on page 78)" |

| Item | Refer to |
|------|--|
| 4 | <p>The most recent version of a particular server or option firmware is available on the following websites:</p> <ul style="list-style-type: none"> • HP Support website (http://www.hp.com/support) • HP ROM-BIOS/Firmware Updates website (http://h18023.www1.hp.com/support/files/server/us/romflash.html) |
| 5 | <p>"General memory problems are occurring" in the <i>HP ProLiant Servers Troubleshooting Guide</i> located on the Documentation CD or on the HP website (http://www.hp.com/support)</p> |
| 6 | <p>Server maintenance and service guide, located on the Documentation CD or the HP website (http://www.hp.com/products/servers/platforms)</p> |
| 7 | <ul style="list-style-type: none"> • Server maintenance and service guide, located on the Documentation CD or the HP website (http://www.hp.com/products/servers/platforms) • "Hardware problems" in the <i>HP ProLiant Servers Troubleshooting Guide</i> located on the Documentation CD or on the HP website (http://www.hp.com/support) |
| 8 | <ul style="list-style-type: none"> • "Server information you need" in the <i>HP ProLiant Servers Troubleshooting Guide</i> located on the Documentation CD or on the HP website (http://www.hp.com/support) • "Operating system information you need" in the <i>HP ProLiant Servers Troubleshooting Guide</i> located on the Documentation CD or on the HP website (http://www.hp.com/support) |
| 9 | <p>"HP contact information (on page 100)"</p> |

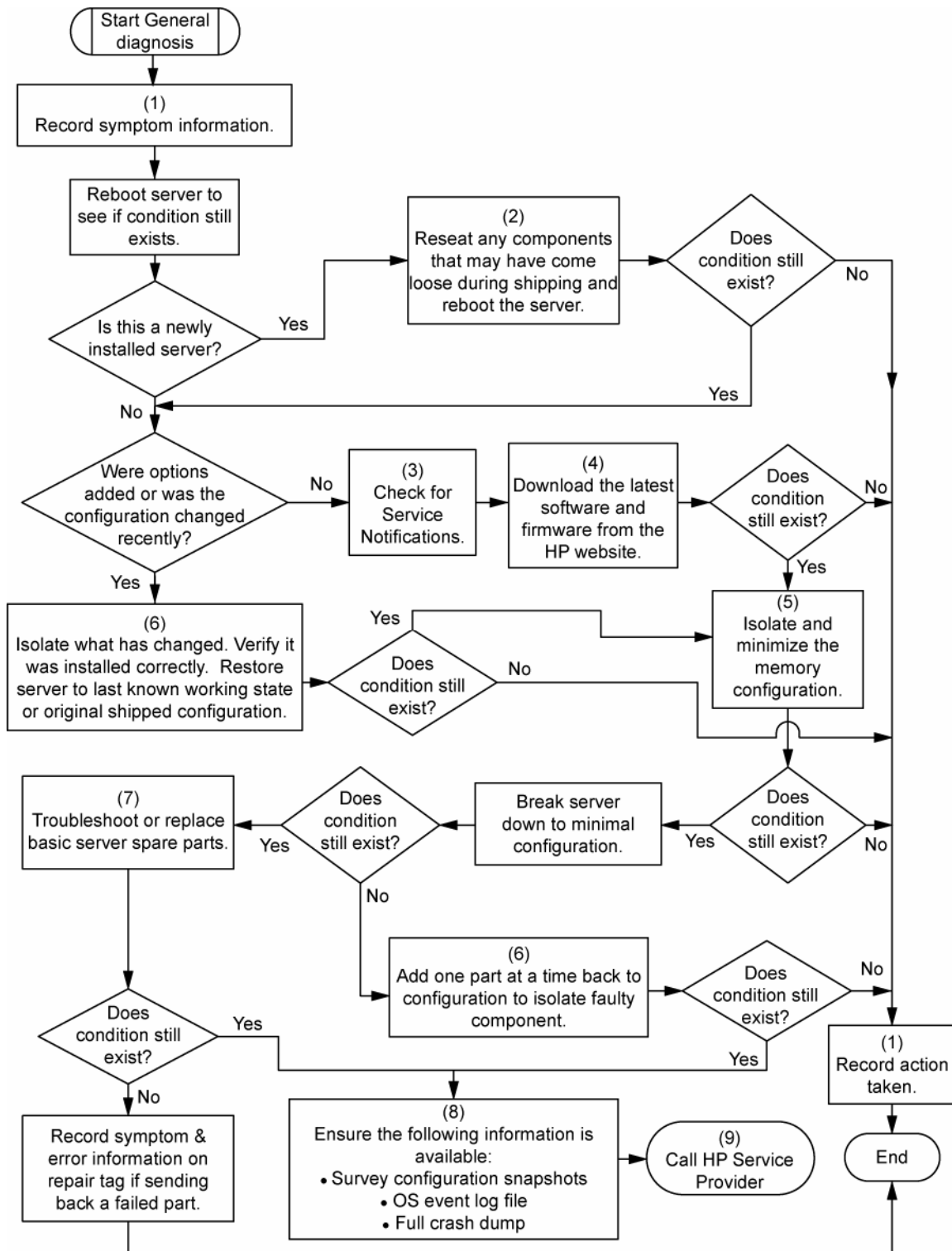

Server power-on problems flowchart

Symptoms:

- The server does not power on.
- The system power LED is off or amber.

- The external health LED is red or amber.
- The internal health LED is red or amber.

NOTE: For the location of server LEDs and information on their statuses, refer to the server documentation.

Possible causes:

- Improperly seated or faulty power supply
- Loose or faulty power cord
- Power source problem
- Power on circuit problem
- Improperly seated component or interlock problem
- Faulty internal component

| Item | Refer to |
|------|--|
| 1 | "Component identification (on page 7)" |
| 2 | "HP Insight Diagnostics (on page 70)" or in the <i>HP ProLiant Servers Troubleshooting Guide</i> located on the Documentation CD or on the HP website (http://www.hp.com/support) |
| 3 | "Loose connections (on page 77)" |
| 4 | Server maintenance and service guide, located on the Documentation CD, or the HP website (http://www.hp.com/products/servers/platforms) |
| 5 | "Integrated Management Log (on page 71)" or in the <i>HP ProLiant Servers Troubleshooting Guide</i> located on the Documentation CD or on the HP website (http://www.hp.com/support) |
| 6 | "Power source problems" in the <i>HP ProLiant Servers Troubleshooting Guide</i> located on the Documentation CD or on the HP website (http://www.hp.com/support) |
| 7 | <ul style="list-style-type: none"> • "Power supply problems" in the <i>HP ProLiant Servers Troubleshooting Guide</i> located on the Documentation CD or on the HP website (http://www.hp.com/support) • Server maintenance and service guide, located on the Documentation CD, or the HP website (http://www.hp.com/products/servers/platforms) |
| 8 | "System open circuits and short circuits" in the <i>HP ProLiant Servers Troubleshooting Guide</i> located on the Documentation CD or on the HP website (http://www.hp.com/support) |

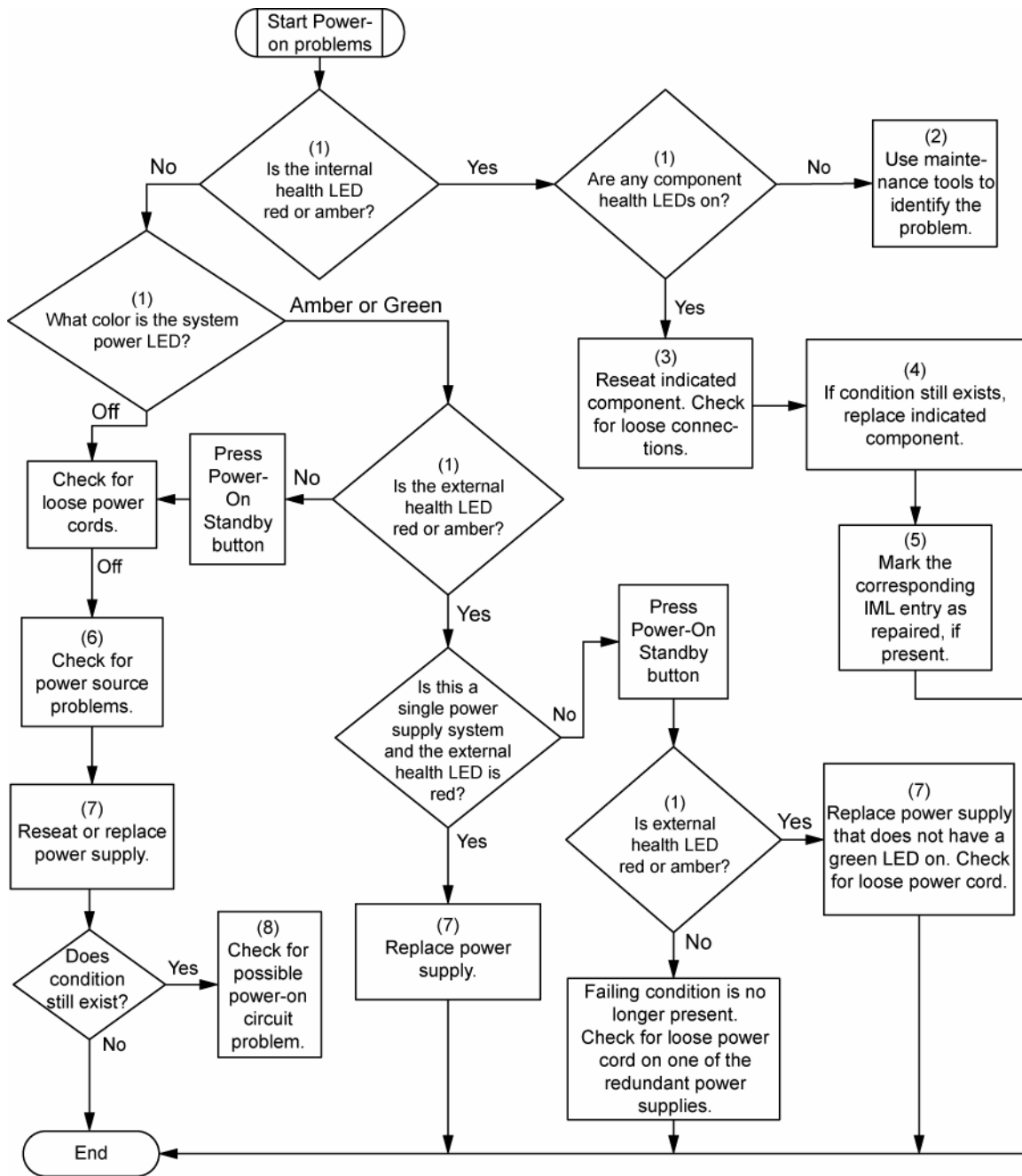

POST problems flowchart

Symptoms:

- Server does not complete POST

NOTE: The server has completed POST when the system attempts to access the boot device.

- Server completes POST with errors

Possible problems:

- Improperly seated or faulty internal component
- Faulty KVM device
- Faulty video device

| Item | Refer to |
|------|--|
| 1 | "POST error messages and beep codes (on page 89)" |
| 2 | "Video problems" in the <i>HP ProLiant Servers Troubleshooting Guide</i> located on the Documentation CD or on the HP website (http://www.hp.com/support) |
| 3 | KVM or iLO 2 documentation |
| 4 | "Loose connections (on page 77)" |
| 5 | "Symptom information (on page 76)" |
| 6 | Server maintenance and service guide, located on the Documentation CD or the HP website (http://www.hp.com/products/servers/platforms) |
| 7 | "Port 85 and iLO messages" in the <i>HP ProLiant Servers Troubleshooting Guide</i> located on the Documentation CD or on the HP website (http://www.hp.com/support) |
| 8 | "General memory problems are occurring" in the <i>HP ProLiant Servers Troubleshooting Guide</i> located on the Documentation CD or on the HP website (http://www.hp.com/support) |
| 9 | <ul style="list-style-type: none"> • "Hardware problems" in the <i>HP ProLiant Servers Troubleshooting Guide</i> located on the Documentation CD or on the HP website (http://www.hp.com/support) • Server maintenance and service guide, located on the Documentation CD or the HP website (http://www.hp.com/products/servers/platforms) |
| 10 | <ul style="list-style-type: none"> • "Server information you need" in the <i>HP ProLiant Servers Troubleshooting Guide</i> located on the Documentation CD or on the HP website (http://www.hp.com/support) • "Operating system information you need" in the <i>HP ProLiant Servers Troubleshooting Guide</i> located on the Documentation CD or on the HP website (http://www.hp.com/support) |

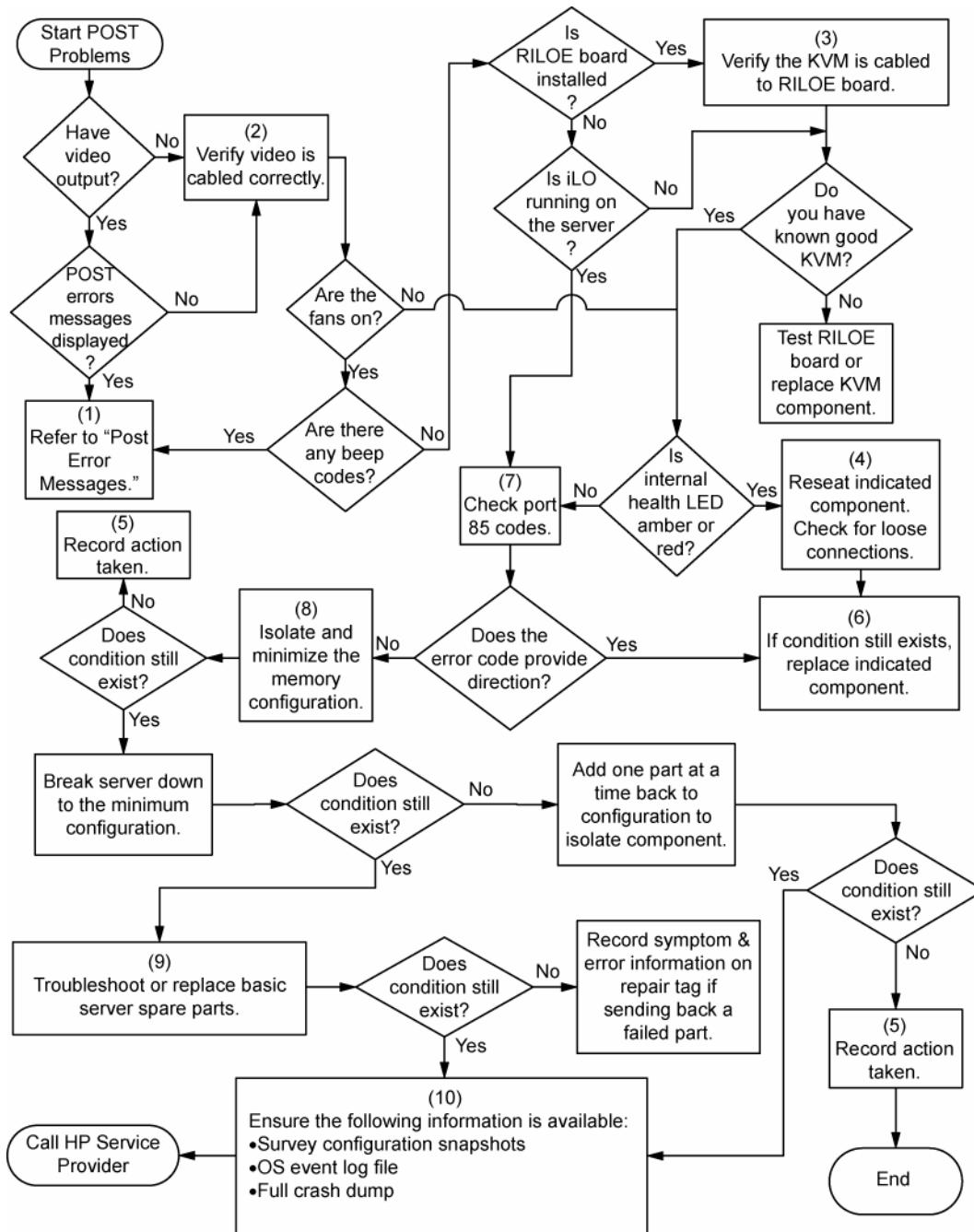

OS boot problems flowchart

Symptoms:

- Server does not boot a previously installed operating system
- Server does not boot SmartStart

Possible causes:

- Corrupted operating system
- Hard drive subsystem problem
- Incorrect boot order setting in RBSU

| Item | Refer to |
|------|---|
| 1 | <p><i>HP ROM-Based Setup Utility User Guide</i> http://www.hp.com/servers/smartstart</p> |
| 2 | <p>"POST problems flowchart (on page 84)"</p> |
| 3 | <ul style="list-style-type: none"> • "Hard drive problems" in the <i>HP ProLiant Servers Troubleshooting Guide</i> located on the Documentation CD or on the HP website (http://www.hp.com/support) • Controller documentation |
| 4 | <p>"HP Insight Diagnostics (on page 70)" or in the <i>HP ProLiant Servers Troubleshooting Guide</i> located on the Documentation CD or on the HP website (http://www.hp.com/support)</p> |
| 5 | <ul style="list-style-type: none"> • "CD-ROM and DVD drive problems" in the <i>HP ProLiant Servers Troubleshooting Guide</i> located on the Documentation CD or on the HP website (http://www.hp.com/support) • Controller documentation • "Loose connections (on page 77)" |
| 6 | <p>"General memory problems are occurring" in the <i>HP ProLiant Servers Troubleshooting Guide</i> located on the Documentation CD or on the HP website (http://www.hp.com/support)</p> |
| 7 | <ul style="list-style-type: none"> • "Operating system problems" in the <i>HP ProLiant Servers Troubleshooting Guide</i> located on the Documentation CD or on the HP website (http://www.hp.com/support) • "HP contact information (on page 100)" |
| 8 | <ul style="list-style-type: none"> • "Hardware problems" in the <i>HP ProLiant Servers Troubleshooting Guide</i> located on the Documentation CD or on the HP website (http://www.hp.com/support) • Server maintenance and service guide, located on the Documentation CD or the HP website (http://www.hp.com/products/servers/platforms) |
| 9 | <p>"General diagnosis flowchart (on page 79)"</p> |

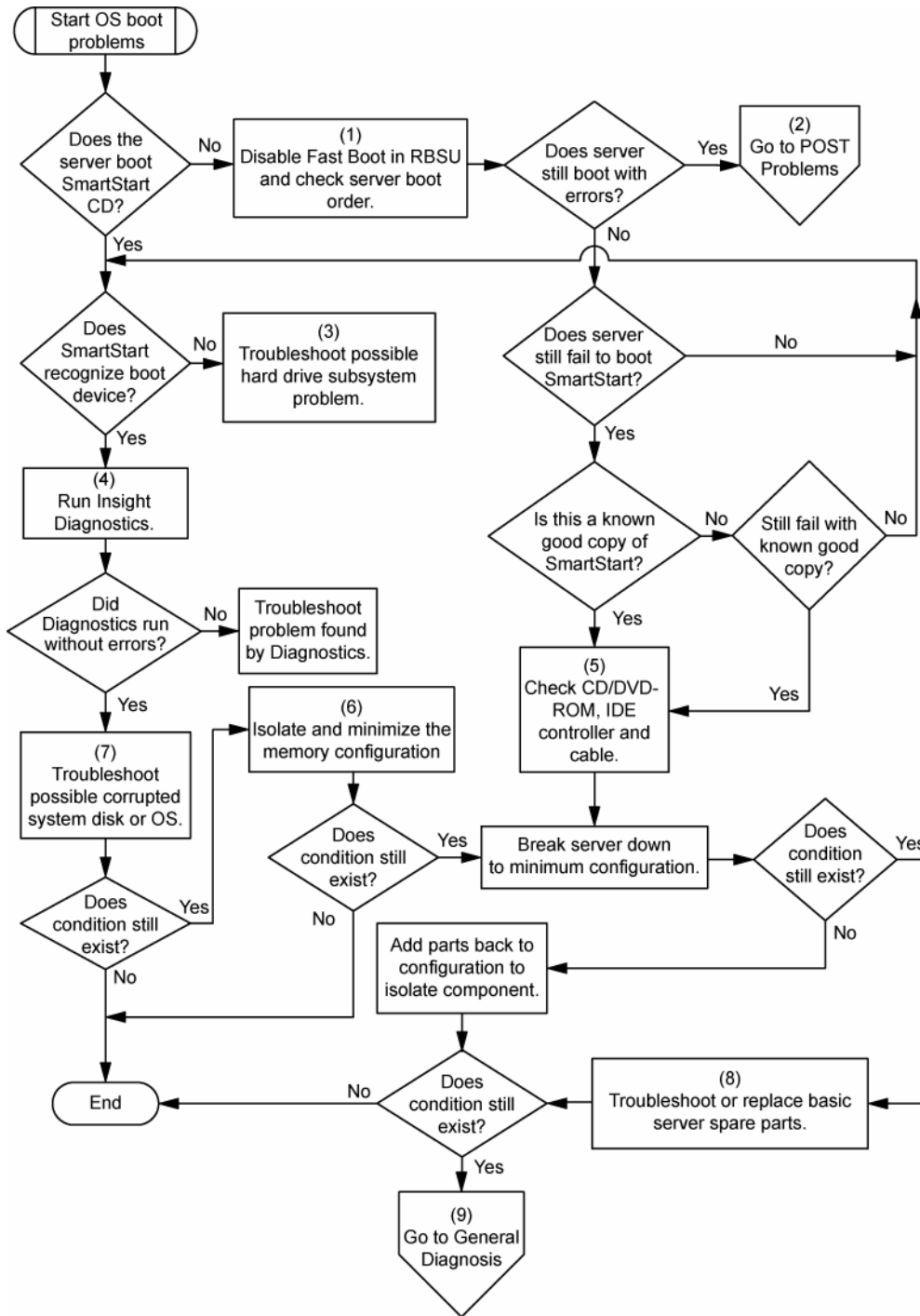

Server fault indications flowchart

Symptoms:

- Server boots, but a fault event is reported by Insight Management Agents (on page 68)
- Server boots, but the internal health LED, external health LED, or component health LED is red or amber

NOTE: For the location of server LEDs and information on their statuses, refer to the server documentation.

Possible causes:

- Improperly seated or faulty internal or external component
- Unsupported component installed
- Redundancy failure
- System overtemperature condition

| Item | Refer to |
|------|--|
| 1 | "Management agents (on page 68)" or in the <i>HP ProLiant Servers Troubleshooting Guide</i> located on the Documentation CD or on the HP website (http://www.hp.com/support) |
| 2 | <ul style="list-style-type: none">• "Integrated Management Log (on page 71)" or in the <i>HP ProLiant Servers Troubleshooting Guide</i> located on the Documentation CD or on the HP website (http://www.hp.com/support)• "Event list error messages" in the <i>HP ProLiant Servers Troubleshooting Guide</i> located on the Documentation CD or on the HP website (http://www.hp.com/support) |
| 3 | "Component identification (on page 7)" |
| 4 | System Management Homepage (https://localhost:2381) |
| 5 | "Power-on problems flowchart ("Server power-on problems flowchart" on page 81)" |
| 6 | <ul style="list-style-type: none">• "Smart Array SCSI Diagnosis feature" in the <i>HP ProLiant Servers Troubleshooting Guide</i> located on the Documentation CD or on the HP website (http://www.hp.com/support)• Server maintenance and service guide, located on the Documentation CD or the HP website (http://www.hp.com/products/servers/platforms)• "HP contact information (on page 100)" |
| 7 | "HP Insight Diagnostics (on page 70)" or in the <i>HP ProLiant Servers Troubleshooting Guide</i> located on the Documentation CD or on the HP website (http://www.hp.com/support) |
| 8 | <ul style="list-style-type: none">• "Hardware problems" in the <i>HP ProLiant Servers Troubleshooting Guide</i> located on the Documentation CD or on the HP website (http://www.hp.com/support)• Server maintenance and service guide, located on the Documentation CD or the HP website (http://www.hp.com/products/servers/platforms) |

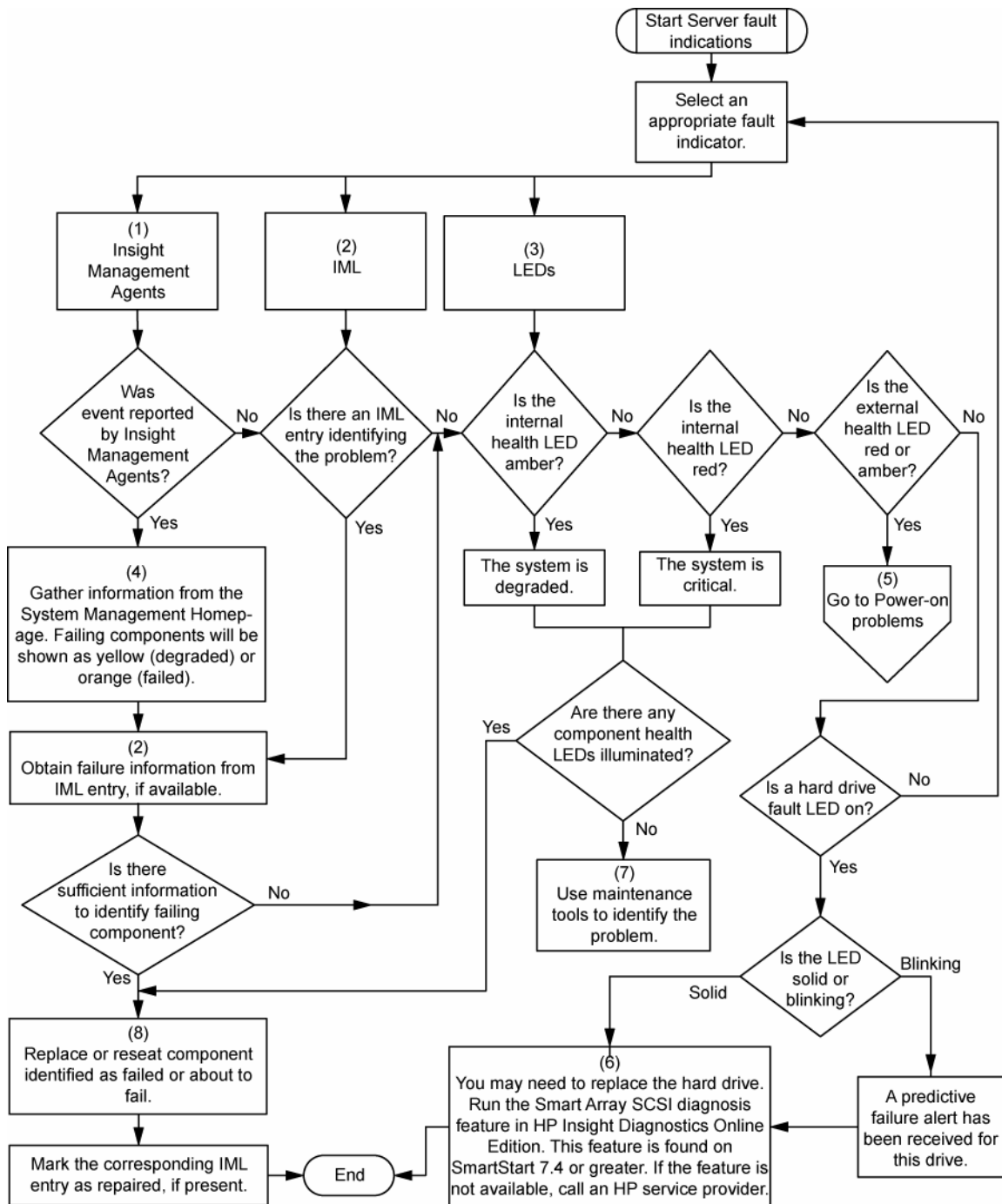

POST error messages and beep codes

For a complete listing of error messages, refer to the "POST error messages" in the *HP ProLiant Servers Troubleshooting Guide* located on the Documentation CD or on the HP website (<http://www.hp.com/support>).



WARNING: To avoid potential problems, ALWAYS read the warnings and cautionary information in the server documentation before removing, replacing, reseating, or modifying system components

Battery replacement

If the server no longer automatically displays the correct date and time, you may need to replace the battery that provides power to the real-time clock. Under normal use, battery life is 5 to 10 years.



WARNING: The computer contains an internal lithium manganese dioxide, a vanadium pentoxide, or an alkaline battery pack. A risk of fire and burns exists if the battery pack is not properly handled. To reduce the risk of personal injury:

- Do not attempt to recharge the battery.
- Do not expose the battery to temperatures higher than 60°C (140°F).
- Do not disassemble, crush, puncture, short external contacts, or dispose of in fire or water.
- Replace only with the spare designated for this product.

To remove the component:

1. Power down the server (on page 23).
2. Extend the server from the rack, if applicable ("[Extend the server from the rack](#)" on page 23).
3. Remove the access panel (on page 24).
4. Remove any hardware that will interfere with accessing the battery.
5. Remove the battery.

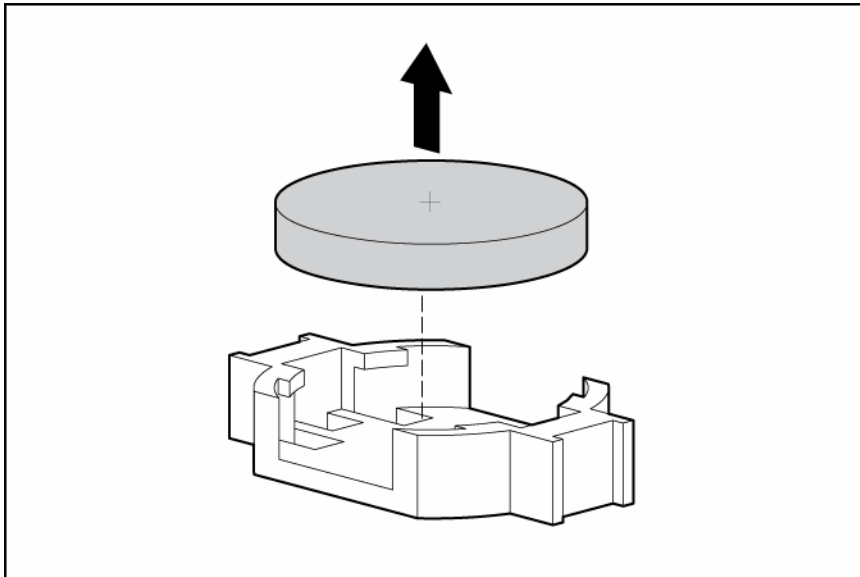

To replace the component, reverse the removal procedure.

For more information about battery replacement or proper disposal, contact an authorized reseller or an authorized service provider.

Regulatory compliance notices

Federal Communications Commission notice

Part 15 of the Federal Communications Commission (FCC) Rules and Regulations has established Radio Frequency (RF) emission limits to provide an interference-free radio frequency spectrum. Many electronic devices, including computers, generate RF energy incidental to their intended function and are, therefore, covered by these rules. These rules place computers and related peripheral devices into two classes, A and B, depending upon their intended installation. Class A devices are those that may reasonably be expected to be installed in a business or commercial environment. Class B devices are those that may reasonably be expected to be installed in a residential environment (for example, personal computers). The FCC requires devices in both classes to bear a label indicating the interference potential of the device as well as additional operating instructions for the user.

FCC rating label

The FCC rating label on the device shows the classification (A or B) of the equipment. Class B devices have an FCC logo or ID on the label. Class A devices do not have an FCC logo or ID on the label. After you determine the class of the device, refer to the corresponding statement.

Class A equipment

This equipment has been tested and found to comply with the limits for a Class A digital device, pursuant to Part 15 of the FCC Rules. These limits are designed to provide reasonable protection against harmful interference when the equipment is operated in a commercial environment. This equipment generates, uses, and can radiate radio frequency energy and, if not installed and used in accordance with the instructions, may cause harmful interference to radio communications. Operation of this equipment in a residential area is likely to cause harmful interference, in which case the user will be required to correct the interference at personal expense.

Class B equipment

This equipment has been tested and found to comply with the limits for a Class B digital device, pursuant to Part 15 of the FCC Rules. These limits are designed to provide reasonable protection against harmful interference in a residential installation. This equipment generates, uses, and can radiate radio frequency energy and, if not installed and used in accordance with the instructions, may cause harmful interference to radio communications. However, there is no guarantee that interference will not occur in a particular installation. If this equipment does cause harmful interference to radio or television reception, which can be determined by turning the equipment off and on, the user is encouraged to try to correct the interference by one or more of the following measures:

- Reorient or relocate the receiving antenna.
- Increase the separation between the equipment and receiver.

- Connect the equipment into an outlet on a circuit that is different from that to which the receiver is connected.
- Consult the dealer or an experienced radio or television technician for help.

Declaration of conformity for products marked with the FCC logo, United States only

This device complies with Part 15 of the FCC Rules. Operation is subject to the following two conditions: (1) this device may not cause harmful interference, and (2) this device must accept any interference received, including interference that may cause undesired operation.

For questions regarding this product, contact us by mail or telephone:

- Hewlett-Packard Company
P. O. Box 692000, Mail Stop 530113
Houston, Texas 77269-2000
- 1-800-HP-INVENT (1-800-474-6836). (For continuous quality improvement, calls may be recorded or monitored.)

For questions regarding this FCC declaration, contact us by mail or telephone:

- Hewlett-Packard Company
P. O. Box 692000, Mail Stop 510101
Houston, Texas 77269-2000
- 1-281-514-3333

To identify this product, refer to the part, series, or model number found on the product.

Modifications

The FCC requires the user to be notified that any changes or modifications made to this device that are not expressly approved by Hewlett-Packard Company may void the user's authority to operate the equipment.

Cables

Connections to this device must be made with shielded cables with metallic RFI/EMI connector hoods in order to maintain compliance with FCC Rules and Regulations.

Canadian notice (Avis Canadien)

Class A equipment

This Class A digital apparatus meets all requirements of the Canadian Interference-Causing Equipment Regulations.

Cet appareil numérique de la classe A respecte toutes les exigences du Règlement sur le matériel brouilleur du Canada.

Class B equipment

This Class B digital apparatus meets all requirements of the Canadian Interference-Causing Equipment Regulations.

Cet appareil numérique de la classe B respecte toutes les exigences du Règlement sur le matériel brouilleur du Canada.

European Union regulatory notice

This product complies with the following EU Directives:

- Low Voltage Directive 2006/95/EC
- EMC Directive 2004/108/EC

Compliance with these directives implies conformity to applicable harmonized European standards (European Norms) which are listed on the EU Declaration of Conformity issued by Hewlett-Packard for this product or product family.

This compliance is indicated by the following conformity marking placed on the product:



This marking is valid for non-Telecom products and EU harmonized Telecom products (e.g. Bluetooth).



This marking is valid for EU non-harmonized Telecom products.

*Notified body number (used only if applicable—refer to the product label)

Hewlett-Packard GmbH, HQ-TRE, Herrenberger Strasse 140, 71034 Boeblingen, Germany

Disposal of waste equipment by users in private households in the European Union



This symbol on the product or on its packaging indicates that this product must not be disposed of with your other household waste. Instead, it is your responsibility to dispose of your waste equipment by handing it over to a designated collection point for the recycling of waste electrical and electronic equipment. The separate collection and recycling of your waste equipment at the time of disposal will help to conserve natural resources and ensure that it is recycled in a manner that protects human health and the environment. For more information about where you can drop off your waste equipment for recycling, please contact your local city office, your household waste disposal service or the shop where you purchased the product.

Japanese notice

ご使用になっている装置にVCCIマークが付いていましたら、次の説明文をお読み下さい。

この装置は、情報処理装置等電波障害自主規制協議会（VCCI）の基準に基づくクラスB情報技術装置です。この装置は、家庭環境で使用することを目的としていますが、この装置がラジオやテレビジョン受信機に近接して使用されると、受信障害を引き起こすことがあります。

取扱説明書に従って正しい取り扱いをして下さい。

VCCIマークが付いていない場合には、次の点にご注意下さい。

この装置は、情報処理装置等電波障害自主規制協議会（VCCI）の基準に基づくクラスA情報技術装置です。この装置を家庭環境で使用すると電波妨害を引き起こすことがあります。この場合には使用者が適切な対策を講ずるよう要求されることがあります。

BSMI notice

警告使用者:

這是甲類的資訊產品，在居住的環境中使用時，可能會造成射頻干擾，在這種情況下，使用者會被要求採取某些適當的對策。

Korean notice

Class A equipment

A급 기기 (업무용 정보통신기기)

이 기기는 업무용으로 전자파적합등록을 한 기기이오니 판매자 또는 사용자는 이 점을 주의하시기 바라며, 만약 잘못판매 또는 구입하였을 때에는 가정용으로 교환하시기 바랍니다.

Class B equipment

B급 기기 (가정용 정보통신기기)

이 기기는 가정용으로 전자파적합등록을 한 기기로서 주거지역에서는 물론 모든지역에서 사용할 수 있습니다.

Laser compliance

This product may be provided with an optical storage device (that is, CD or DVD drive) and/or fiber optic transceiver. Each of these devices contains a laser that is classified as a Class 1 Laser Product in accordance with US FDA regulations and the IEC 60825-1. The product does not emit hazardous laser radiation.

Each laser product complies with 21 CFR 1040.10 and 1040.11 except for deviations pursuant to Laser Notice No. 50, dated May 27, 2001; and with IEC 60825-1:1993/A2:2001.



WARNING: Use of controls or adjustments or performance of procedures other than those specified herein or in the laser product's installation guide may result in hazardous radiation exposure. To reduce the risk of exposure to hazardous radiation:

- Do not try to open the module enclosure. There are no user-serviceable components inside.
- Do not operate controls, make adjustments, or perform procedures to the laser device other than those specified herein.
- Allow only HP Authorized Service technicians to repair the unit.

The Center for Devices and Radiological Health (CDRH) of the U.S. Food and Drug Administration implemented regulations for laser products on August 2, 1976. These regulations apply to laser products manufactured from August 1, 1976. Compliance is mandatory for products marketed in the United States.

Battery replacement notice



WARNING: The computer contains an internal lithium manganese dioxide, a vanadium pentoxide, or an alkaline battery pack. A risk of fire and burns exists if the battery pack is not properly handled. To reduce the risk of personal injury:

- Do not attempt to recharge the battery.
- Do not expose the battery to temperatures higher than 60°C (140°F).
- Do not disassemble, crush, puncture, short external contacts, or dispose of in fire or water.



Batteries, battery packs, and accumulators should not be disposed of together with the general household waste. To forward them to recycling or proper disposal, use the public collection system or return them to HP, an authorized HP Partner, or their agents.

For more information about battery replacement or proper disposal, contact an authorized reseller or an authorized service provider.

Taiwan battery recycling notice

The Taiwan EPA requires dry battery manufacturing or importing firms in accordance with Article 15 of the Waste Disposal Act to indicate the recovery marks on the batteries used in sales, giveaway or promotion. Contact a qualified Taiwanese recycler for proper battery disposal.



Power cord statement for Japan

製品には、同梱された電源コードをお使い下さい。
同梱された電源コードは、他の製品では使用出来ません。

Electrostatic discharge

Preventing electrostatic discharge

To prevent damaging the system, be aware of the precautions you need to follow when setting up the system or handling parts. A discharge of static electricity from a finger or other conductor may damage system boards or other static-sensitive devices. This type of damage may reduce the life expectancy of the device.

To prevent electrostatic damage:

- Avoid hand contact by transporting and storing products in static-safe containers.
- Keep electrostatic-sensitive parts in their containers until they arrive at static-free workstations.
- Place parts on a grounded surface before removing them from their containers.
- Avoid touching pins, leads, or circuitry.
- Always be properly grounded when touching a static-sensitive component or assembly.

Grounding methods to prevent electrostatic discharge

Several methods are used for grounding. Use one or more of the following methods when handling or installing electrostatic-sensitive parts:

- Use a wrist strap connected by a ground cord to a grounded workstation or computer chassis. Wrist straps are flexible straps with a minimum of 1 megohm ± 10 percent resistance in the ground cords. To provide proper ground, wear the strap snug against the skin.
- Use heel straps, toe straps, or boot straps at standing workstations. Wear the straps on both feet when standing on conductive floors or dissipating floor mats.
- Use conductive field service tools.
- Use a portable field service kit with a folding static-dissipating work mat.

If you do not have any of the suggested equipment for proper grounding, have an authorized reseller install the part.

For more information on static electricity or assistance with product installation, contact an authorized reseller.

Specifications

Environmental specifications

| Specification | Value |
|--|--------------------------------|
| Temperature range* | |
| Operating | 10°C to 35°C (50°F to 95°F) |
| Shipping | -30°C to 50°C (-22°F to 122°F) |
| Storage | -30°C to 60°C (-22°F to 140°F) |
| Maximum wet bulb temperature | 28°C (82.4°F) |
| Relative humidity (noncondensing)** | |
| Operating | 10% to 90% |
| Non-operating | 5% to 95% |

* All temperature ratings shown are for sea level. An altitude derating of 1°C per 300 m (1.8°F per 1,000 ft) to 3048 m (10,000 ft) is applicable. No direct sunlight allowed.

** Storage maximum humidity of 95% is based on a maximum temperature of 45°C (113°F). Altitude maximum for storage corresponds to a pressure minimum of 70 KPa.

Server specifications

| Specification | Value |
|------------------------------|--|
| Dimensions | |
| Height | 8.59 cm (3.38 in) |
| Depth | 66.07 cm (26.01 in) |
| Width | 44.54 cm (17.54 in) |
| Weight (maximum) | 27.22 kg (60 lb) |
| Weight (no drives installed) | 20.41 kg (47.18 lb) |
| Input requirements | |
| Rated input voltage | 100 to 132 VAC, 200 to 240 VAC |
| Rated input frequency | 50 Hz to 60 Hz |
| Rated input current | 10 A at 100 VAC 4.9 A at 200 VAC |
| Rated input power | 980 W at 100V AC input 960 W at 200V AC input |

| | |
|----------------------------|---|
| BTUs per hour | 3344 at 100V to 120V AC input 3277 at 200V to 240V AC input |
| Power supply output | |
| Rated steady-state power | 800 W at 100V AC input 850 W at 120V AC input 1000 W at 200V to 240V AC input |
| Maximum peak power | 800 W at 100V AC input 850 W at 120V AC input 1000 W at 200V to 240V AC input |

Technical support

Before you contact HP

Be sure to have the following information available before you call HP:

- Technical support registration number (if applicable)
- Product serial number
- Product model name and number
- Product identification number
- Applicable error messages
- Add-on boards or hardware
- Third-party hardware or software
- Operating system type and revision level

HP contact information

For the name of the nearest HP authorized reseller:

- In the United States, see the HP US service locator webpage (http://www.hp.com/service_locator).
- In other locations, see the Contact HP worldwide (in English) webpage (<http://welcome.hp.com/country/us/en/wwcontact.html>).

For HP technical support:

- In the United States, for contact options see the Contact HP United States webpage (http://welcome.hp.com/country/us/en/contact_us.html). To contact HP by phone:
 - Call 1-800-HP-INVENT (1-800-474-6836). This service is available 24 hours a day, 7 days a week. For continuous quality improvement, calls may be recorded or monitored.
 - If you have purchased a Care Pack (service upgrade), call 1-800-633-3600. For more information about Care Packs, refer to the HP website (<http://www.hp.com>).
- In other locations, see the Contact HP worldwide (in English) webpage (<http://welcome.hp.com/country/us/en/wwcontact.html>).

Customer Self Repair

HP products are designed with many Customer Self Repair (CSR) parts to minimize repair time and allow for greater flexibility in performing defective parts replacement. If during the diagnosis period HP (or HP service providers or service partners) identifies that the repair can be accomplished by the use of a CSR part, HP will ship that part directly to you for replacement. There are two categories of CSR parts:

- **Mandatory**—Parts for which customer self repair is mandatory. If you request HP to replace these parts, you will be charged for the travel and labor costs of this service.
- **Optional**—Parts for which customer self repair is optional. These parts are also designed for customer self repair. If, however, you require that HP replace them for you, there may or may not be additional charges, depending on the type of warranty service designated for your product.

NOTE: Some HP parts are not designed for customer self repair. In order to satisfy the customer warranty, HP requires that an authorized service provider replace the part. These parts are identified as "No" in the Illustrated Parts Catalog.

Based on availability and where geography permits, CSR parts will be shipped for next business day delivery. Same day or four-hour delivery may be offered at an additional charge where geography permits. If assistance is required, you can call the HP Technical Support Center and a technician will help you over the telephone. HP specifies in the materials shipped with a replacement CSR part whether a defective part must be returned to HP. In cases where it is required to return the defective part to HP, you must ship the defective part back to HP within a defined period of time, normally five (5) business days. The defective part must be returned with the associated documentation in the provided shipping material. Failure to return the defective part may result in HP billing you for the replacement. With a customer self repair, HP will pay all shipping and part return costs and determine the courier/carrier to be used.

For more information about HP's Customer Self Repair program, contact your local service provider. For the North American program, refer to the HP website (<http://www.hp.com/go/selfrepair>).

Réparation par le client (CSR)

Les produits HP comportent de nombreuses pièces CSR (Customer Self Repair = réparation par le client) afin de minimiser les délais de réparation et faciliter le remplacement des pièces défectueuses. Si pendant la période de diagnostic, HP (ou ses partenaires ou mainteneurs agréés) détermine que la réparation peut être effectuée à l'aide d'une pièce CSR, HP vous l'envoie directement. Il existe deux catégories de pièces CSR:

- **Obligatoire** - Pièces pour lesquelles la réparation par le client est obligatoire. Si vous demandez à HP de remplacer ces pièces, les coûts de déplacement et main d'œuvre du service vous seront facturés.
- **Facultatif** - Pièces pour lesquelles la réparation par le client est facultative. Ces pièces sont également conçues pour permettre au client d'effectuer lui-même la réparation. Toutefois, si vous demandez à HP de remplacer ces pièces, l'intervention peut ou non vous être facturée, selon le type de garantie applicable à votre produit.

REMARQUE: Certaines pièces HP ne sont pas conçues pour permettre au client d'effectuer lui-même la réparation. Pour que la garantie puisse s'appliquer, HP exige que le remplacement de la pièce soit effectué par un Mainteneur Agréé. Ces pièces sont identifiées par la mention "Non" dans le Catalogue illustré.

Les pièces CSR sont livrées le jour ouvré suivant, dans la limite des stocks disponibles et selon votre situation géographique. Si votre situation géographique le permet et que vous demandez une livraison le jour même ou dans les 4 heures, celle-ci vous sera facturée. Pour bénéficier d'une assistance téléphonique, appelez le Centre d'assistance technique HP. Dans les documents envoyés avec la pièce de rechange CSR, HP précise s'il est nécessaire de lui retourner la pièce défectueuse. Si c'est le cas, vous devez le faire dans le délai indiqué, généralement cinq (5) jours ouvrés. La pièce et sa documentation doivent être retournées dans l'emballage fourni. Si vous ne retournez pas la pièce défectueuse, HP se réserve le droit de vous facturer les coûts de remplacement. Dans le cas d'une pièce CSR, HP supporte

l'ensemble des frais d'expédition et de retour, et détermine la société de courses ou le transporteur à utiliser.

Pour plus d'informations sur le programme CSR de HP, contactez votre Mainteneur Agréé local. Pour plus d'informations sur ce programme en Amérique du Nord, consultez le site Web HP (<http://www.hp.com/go/selfrepair>).

Riparazione da parte del cliente

Per abbreviare i tempi di riparazione e garantire una maggiore flessibilità nella sostituzione di parti difettose, i prodotti HP sono realizzati con numerosi componenti che possono essere riparati direttamente dal cliente (CSR, Customer Self Repair). Se in fase di diagnostica HP (o un centro di servizi o di assistenza HP) identifica il guasto come riparabile mediante un ricambio CSR, HP lo spedisce direttamente al cliente per la sostituzione. Vi sono due categorie di parti CSR:

- **Obbligatorie** – Parti che devono essere necessariamente riparate dal cliente. Se il cliente ne affida la riparazione ad HP, deve sostenere le spese di spedizione e di manodopera per il servizio.
- **Opzionali** – Parti la cui riparazione da parte del cliente è facoltativa. Si tratta comunque di componenti progettati per questo scopo. Se tuttavia il cliente ne richiede la sostituzione ad HP, potrebbe dover sostenere spese aggiuntive a seconda del tipo di garanzia previsto per il prodotto.

NOTA: alcuni componenti HP non sono progettati per la riparazione da parte del cliente. Per rispettare la garanzia, HP richiede che queste parti siano sostituite da un centro di assistenza autorizzato. Tali parti sono identificate da un "No" nel Catalogo illustrato dei componenti.

In base alla disponibilità e alla località geografica, le parti CSR vengono spedite con consegna entro il giorno lavorativo seguente. La consegna nel giorno stesso o entro quattro ore è offerta con un supplemento di costo solo in alcune zone. In caso di necessità si può richiedere l'assistenza telefonica di un addetto del centro di supporto tecnico HP. Nel materiale fornito con una parte di ricambio CSR, HP specifica se il cliente deve restituire dei componenti. Qualora sia richiesta la resa ad HP del componente difettoso, lo si deve spedire ad HP entro un determinato periodo di tempo, generalmente cinque (5) giorni lavorativi. Il componente difettoso deve essere restituito con la documentazione associata nell'imballo di spedizione fornito. La mancata restituzione del componente può comportare la fatturazione del ricambio da parte di HP. Nel caso di riparazione da parte del cliente, HP sostiene tutte le spese di spedizione e resa e sceglie il corriere/vettore da utilizzare.

Per ulteriori informazioni sul programma CSR di HP contattare il centro di assistenza di zona. Per il programma in Nord America fare riferimento al sito Web **HP** (<http://www.hp.com/go/selfrepair>).

Customer Self Repair

HP Produkte enthalten viele CSR-Teile (Customer Self Repair), um Reparaturzeiten zu minimieren und höhere Flexibilität beim Austausch defekter Bauteile zu ermöglichen. Wenn HP (oder ein HP Servicepartner) bei der Diagnose feststellt, dass das Produkt mithilfe eines CSR-Teils repariert werden kann, sendet Ihnen HP dieses Bauteil zum Austausch direkt zu. CSR-Teile werden in zwei Kategorien unterteilt:

- **Zwingend** – Teile, für die das Customer Self Repair-Verfahren zwingend vorgegeben ist. Wenn Sie den Austausch dieser Teile von HP vornehmen lassen, werden Ihnen die Anfahrt- und Arbeitskosten für diesen Service berechnet.
- **Optional** – Teile, für die das Customer Self Repair-Verfahren optional ist. Diese Teile sind auch für Customer Self Repair ausgelegt. Wenn Sie jedoch den Austausch dieser Teile von HP vornehmen

lassen möchten, können bei diesem Service je nach den für Ihr Produkt vorgesehenen Garantiebedingungen zusätzliche Kosten anfallen.

HINWEIS: Einige Teile sind nicht für Customer Self Repair ausgelegt. Um den Garantieanspruch des Kunden zu erfüllen, muss das Teil von einem HP Servicepartner ersetzt werden. Im illustrierten Teilekatalog sind diese Teile mit „No“ bzw. „Nein“ gekennzeichnet.

CSR-Teile werden abhängig von der Verfügbarkeit und vom Lieferziel am folgenden Geschäftstag geliefert. Für bestimmte Standorte ist eine Lieferung am selben Tag oder innerhalb von vier Stunden gegen einen Aufpreis verfügbar. Wenn Sie Hilfe benötigen, können Sie das HP technische Support Center anrufen und sich von einem Mitarbeiter per Telefon helfen lassen. Den Materialien, die mit einem CSR-Ersatzteil geliefert werden, können Sie entnehmen, ob das defekte Teil an HP zurückgeschickt werden muss. Wenn es erforderlich ist, das defekte Teil an HP zurückzuschicken, müssen Sie dies innerhalb eines vorgegebenen Zeitraums tun, in der Regel innerhalb von fünf (5) Geschäftstagen. Das defekte Teil muss mit der zugehörigen Dokumentation in der Verpackung zurückgeschickt werden, die im Lieferumfang enthalten ist. Wenn Sie das defekte Teil nicht zurückschicken, kann HP Ihnen das Ersatzteil in Rechnung stellen. Im Falle von Customer Self Repair kommt HP für alle Kosten für die Lieferung und Rücksendung auf und bestimmt den Kurier-/Frachtdienst.

Weitere Informationen über das HP Customer Self Repair Programm erhalten Sie von Ihrem Servicepartner vor Ort. Informationen über das CSR-Programm in Nordamerika finden Sie auf der HP Website unter (<http://www.hp.com/go/selfrepair>).

Reparaciones del propio cliente

Los productos de HP incluyen muchos componentes que el propio usuario puede reemplazar (*Customer Self Repair*, CSR) para minimizar el tiempo de reparación y ofrecer una mayor flexibilidad a la hora de realizar sustituciones de componentes defectuosos. Si, durante la fase de diagnóstico, HP (o los proveedores o socios de servicio de HP) identifica que una reparación puede llevarse a cabo mediante el uso de un componente CSR, HP le enviará dicho componente directamente para que realice su sustitución. Los componentes CSR se clasifican en dos categorías:

- **Obligatorio:** componentes para los que la reparación por parte del usuario es obligatoria. Si solicita a HP que realice la sustitución de estos componentes, tendrá que hacerse cargo de los gastos de desplazamiento y de mano de obra de dicho servicio.
- **Opcional:** componentes para los que la reparación por parte del usuario es opcional. Estos componentes también están diseñados para que puedan ser reparados por el usuario. Sin embargo, si precisa que HP realice su sustitución, puede o no conllevar costes adicionales, dependiendo del tipo de servicio de garantía correspondiente al producto.

NOTA: Algunos componentes no están diseñados para que puedan ser reparados por el usuario. Para que el usuario haga valer su garantía, HP pone como condición que un proveedor de servicios autorizado realice la sustitución de estos componentes. Dichos componentes se identifican con la palabra "No" en el catálogo ilustrado de componentes.

Según la disponibilidad y la situación geográfica, los componentes CSR se enviarán para que lleguen a su destino al siguiente día laborable. Si la situación geográfica lo permite, se puede solicitar la entrega en el mismo día o en cuatro horas con un coste adicional. Si precisa asistencia técnica, puede llamar al Centro de asistencia técnica de HP y recibirá ayuda telefónica por parte de un técnico. Con el envío de materiales para la sustitución de componentes CSR, HP especificará si los componentes defectuosos deberán devolverse a HP. En aquellos casos en los que sea necesario devolver algún componente a HP, deberá hacerlo en el periodo de tiempo especificado, normalmente cinco días laborables. Los componentes defectuosos deberán devolverse con toda la documentación relacionada y con el embalaje

de envío. Si no enviara el componente defectuoso requerido, HP podrá cobrarle por el de sustitución. En el caso de todas sustituciones que lleve a cabo el cliente, HP se hará cargo de todos los gastos de envío y devolución de componentes y escogerá la empresa de transporte que se utilice para dicho servicio.

Para obtener más información acerca del programa de Reparaciones del propio cliente de HP, póngase en contacto con su proveedor de servicios local. Si está interesado en el programa para Norteamérica, visite la página web de HP siguiente (<http://www.hp.com/go/selfrepair>).

Customer Self Repair

Veel onderdelen in HP producten zijn door de klant zelf te repareren, waardoor de reparatieduur tot een minimum beperkt kan blijven en de flexibiliteit in het vervangen van defecte onderdelen groter is. Deze onderdelen worden CSR-onderdelen (Customer Self Repair) genoemd. Als HP (of een HP Service Partner) bij de diagnose vaststelt dat de reparatie kan worden uitgevoerd met een CSR-onderdeel, verzendt HP dat onderdeel rechtstreeks naar u, zodat u het defecte onderdeel daarmee kunt vervangen. Er zijn twee categorieën CSR-onderdelen:

- **Verplicht:** Onderdelen waarvoor reparatie door de klant verplicht is. Als u HP verzoekt deze onderdelen voor u te vervangen, worden u voor deze service reiskosten en arbeidsloon in rekening gebracht.
- **Optioneel:** Onderdelen waarvoor reparatie door de klant optioneel is. Ook deze onderdelen zijn ontworpen voor reparatie door de klant. Als u echter HP verzoekt deze onderdelen voor u te vervangen, kunnen daarvoor extra kosten in rekening worden gebracht, afhankelijk van het type garantieservice voor het product.

OPMERKING: Sommige HP onderdelen zijn niet ontwikkeld voor reparatie door de klant. In verband met de garantievoorzwaarden moet het onderdeel door een geautoriseerde Service Partner worden vervangen. Deze onderdelen worden in de geïllustreerde onderdelencatalogus aangemerkt met "Nee".

Afhankelijk van de leverbaarheid en de locatie worden CSR-onderdelen verzonden voor levering op de eerstvolgende werkdag. Levering op dezelfde dag of binnen vier uur kan tegen meerkosten worden aangeboden, indien dit mogelijk is gezien de locatie. Indien assistentie gewenst is, belt u een HP Service Partner om via de telefoon technische ondersteuning te ontvangen. HP vermeldt in de documentatie bij het vervangende CSR-onderdeel of het defecte onderdeel aan HP moet worden geretourneerd. Als het defecte onderdeel aan HP moet worden teruggezonden, moet u het defecte onderdeel binnen een bepaalde periode, gewoonlijk vijf (5) werkdagen, retourneren aan HP. Het defecte onderdeel moet met de bijbehorende documentatie worden geretourneerd in het meegeleverde verpakkingsmateriaal. Als u het defecte onderdeel niet terugzendt, kan HP u voor het vervangende onderdeel kosten in rekening brengen. Bij reparatie door de klant betaalt HP alle verzendkosten voor het vervangende en geretourneerde onderdeel en kiest HP zelf welke koerier/transportonderneming hiervoor wordt gebruikt.

Neem contact op met een Service Partner voor meer informatie over het Customer Self Repair programma van HP. Informatie over Service Partners vindt u op de **HP website** (<http://www.hp.nl/services/servicepartners>).

Reparo feito pelo cliente

Os produtos da HP são projetados com muitas peças para reparo feito pelo cliente (CSR) de modo a minimizar o tempo de reparo e permitir maior flexibilidade na substituição de peças com defeito. Se, durante o período de diagnóstico, a HP (ou fornecedores/parceiros de serviço da HP) concluir que o reparo pode ser efetuado pelo uso de uma peça CSR, a peça de reposição será enviada diretamente ao cliente. Existem duas categorias de peças CSR:

- **Obrigatória** – Peças cujo reparo feito pelo cliente é obrigatório. Se desejar que a HP substitua essas peças, serão cobradas as despesas de transporte e mão-de-obra do serviço.
- **Opcional** – Peças cujo reparo feito pelo cliente é opcional. Essas peças também são projetadas para o reparo feito pelo cliente. No entanto, se desejar que a HP as substitua, pode haver ou não a cobrança de taxa adicional, dependendo do tipo de serviço de garantia destinado ao produto.

OBSERVAÇÃO: Algumas peças da HP não são projetadas para o reparo feito pelo cliente. A fim de cumprir a garantia do cliente, a HP exige que um técnico autorizado substitua a peça. Essas peças estão identificadas com a marca "No" (Não), no catálogo de peças ilustrado.

Conforme a disponibilidade e o local geográfico, as peças CSR serão enviadas no primeiro dia útil após o pedido. Onde as condições geográficas permitirem, a entrega no mesmo dia ou em quatro horas pode ser feita mediante uma taxa adicional. Se precisar de auxílio, entre em contato com o Centro de suporte técnico da HP para que um técnico o ajude por telefone. A HP especifica nos materiais fornecidos com a peça CSR de reposição se a peça com defeito deve ser devolvida à HP. Nos casos em que isso for necessário, é preciso enviar a peça com defeito à HP dentro do período determinado, normalmente cinco (5) dias úteis. A peça com defeito deve ser enviada com a documentação correspondente no material de transporte fornecido. Caso não o faça, a HP poderá cobrar a reposição. Para as peças de reparo feito pelo cliente, a HP paga todas as despesas de transporte e de devolução da peça e determina a transportadora/serviço postal a ser utilizado.

Para obter mais informações sobre o programa de reparo feito pelo cliente da HP, entre em contato com o fornecedor de serviços local. Para o programa norte-americano, visite o site da HP (<http://www.hp.com/go/selfrepair>).

顧客自己修理保証サービス

修理時間を短縮し、故障部品の交換における高い柔軟性を確保するために、HP製品には多数の顧客自己修理（CSR）部品があります。診断の際に、CSR部品を使用すれば修理ができるとHP（HPまたはHP正規保守代理店）が判断した場合、HPはその部品を直接、お客様に発送し、お客様に交換していただきます。CSR部品には以下の2通りがあります。

- **必須** - 顧客自己修理が必須の部品。当該部品について、もしもお客様がHPに交換作業を依頼される場合には、その修理サービスに関する交通費および人件費がお客様に請求されます。
- **任意** - 顧客自己修理が任意である部品。この部品も顧客自己修理用です。当該部品について、もしもお客様がHPに交換作業を依頼される場合には、お買い上げの製品に適用される保証サービス内容の範囲内においては、別途費用を負担していただくことなく保証サービスを受けることができます。

注：HP製品の一部の部品は、顧客自己修理用ではありません。製品の保証を継続するためには、HPまたはHP正規保守代理店による交換作業が必須となります。部品カタログには、当該部品が顧客自己修理除外品である旨が記載されています。

部品供給が可能な場合、地域によっては、CSR部品を翌営業日に届くように発送します。また、地域によっては、追加費用を負担いただくことにより同日または4時間以内に届くように発送することも可能な場合があります。サポートが必要なときは、HPの修理受付窓口へ電話していただければ、技術者が電話でアドバイスします。交換用のCSR部品または同梱物には、故障部品をHPに返送する必要があるかどうかが表示されています。故障部品をHPに返送する必要がある場合は、指定期限内（通常は5営業日以内）に故障部品をHPに返送してください。故障部品を返送する場合は、届いた時の梱包箱に関連書類とともに入れてください。故障部品を返送しない場合、HPから部品費用が請求されます。顧客自己修理の際には、HPは送料および部品返送費を全額負担し、使用する宅配便会社や運送会社を指定します。

客户自行维修

HP 产品提供许多客户自行维修 (CSR) 部件，以尽可能缩短维修时间和在更换缺陷部件方面提供更大的灵活性。如果在诊断期间 HP（或 HP 服务提供商或服务合作伙伴）确定可以通过使用 CSR 部件完成维修，HP 将直接把该部件发送给您进行更换。有两类 CSR 部件：

- **强制性的** — 要求客户必须自行维修的部件。如果您请求 HP 更换这些部件，则必须为该服务支付差旅费和人工费用。
- **可选的** — 客户可以选择是否自行维修的部件。这些部件也是为客户自行维修设计的。不过，如果您要求 HP 为您更换这些部件，则根据为您的产品指定的保修服务类型，HP 可能收取或不再收取任何附加费用。

注：某些 HP 部件的设计并未考虑客户自行维修。为了满足客户保修的需要，HP 要求授权服务提供商更换相关部件。这些部件在部件图解目录中标记为“否”。

CSR 部件将在下一个工作日发运（取决于备货情况和允许的地理范围）。在允许的地理范围内，可在当天或四小时内发运，但要收取额外费用。如果需要帮助，您可以致电 HP 技术支持中心，将会有技术人员通过电话为您提供帮助。HP 会在随更换的 CSR 部件发运的材料中指明是否必须将有缺陷的部件返还给 HP。如果要求您将缺陷的部件返还给 HP，那么您必须在指定期限内（通常是五 (5) 个工作日）将缺陷部件发给 HP。有缺陷的部件必须随所提供的发运材料中的相关文件一起返还。如果未能送还缺陷的部件，HP 可能会要求您支付更换费用。客户自行维修时，HP 将承担所有相关运输和部件返回费用，并指定快递商/承运商。

有关 HP 客户自行维修计划的详细信息，请与您当地的服务提供商联系。有关北美地区的计划，请访问 HP 网站 (<http://www.hp.com/go/selfrepair>)。

客戶自行維修

HP 產品設計了許多「客戶自行維修」(CSR) 的零件以減少維修時間，並且使得更換瑕疵零件時能有更大的彈性。如果在診斷期間 HP (或 HP 服務供應商或維修夥伴) 辨認出此項維修工作可以藉由使用 CSR 零件來完成，則 HP 將直接寄送該零件給您作更換。CSR 零件分為兩種類別：

- **強制的** — 客戶自行維修所使用的零件是強制性的。如果您要求 HP 更換這些零件，HP 將會向您收取此服務所需的外出費用與勞動成本。
- **選購的** — 客戶自行維修所使用的零件是選購的。這些零件也設計用於客戶自行維修之用。不過，如果您要求 HP 為您更換，則可能需要也可能不需要負擔額外的費用，端視針對此產品指定的保固服務類型而定。

備註：某些 HP 零件沒有消費者可自行維修的設計。為符合客戶保固，HP 需要授權的服務供應商更換零件。這些零件在圖示的零件目錄中，被標示為「否」。

基於材料取得及環境允許的情況下，CSR 零件將於下一個工作日以快遞寄送。在環境的允許下當天或四小時內送達，則可能需要額外的費用。若您需要協助，可致電「HP 技術支援中心」，會有一位技術人員透過電話來協助您。不論損壞的零件是否必須退回，HP 皆會在與 CSR 替換零件一起運送的材料中註明。若要將損壞的零件退回 HP，您必須在指定的一段時間內（通常為五 (5) 個工作天），將損壞的零件寄回 HP。損壞的零件必須與寄送資料中隨附的相關技術文件一併退還。如果無法退還損壞的零件，HP 可能要向您收取替換費用。針對客戶自行維修情形，HP 將負責所有運費及零件退還費用並指定使用何家快遞/貨運公司。

如需 HP 的「客戶自行維修」方案詳細資訊，請連絡您當地的服務供應商。至於北美方案，請參閱 HP 網站 (<http://www.hp.com/go/selfrepair>)。

고객 셀프 수리

HP 제품은 수리 시간을 최소화하고 결함이 있는 부품 교체 시 더욱 융통성을 발휘할 수 있도록 하기 위해 고객 셀프 수리(CSR) 부품을 다량 사용하여 설계되었습니다. 진단 기간 동안 HP(또는 HP 서비스 공급업체 또는 서비스 협력업체)에서 CSR 부품을 사용하여 수리가 가능하다고 판단되면 HP는 해당 부품을 바로 사용자에게 보내어 사용자가 교체할 수 있도록 합니다. CSR 부품에는 두 가지 종류가 있습니다.

- **고객 셀프 수리가 의무 사항인 필수 부품.** 사용자가 HP에 이 부품의 교체를 요청할 경우 이 서비스에 대한 출장비 및 작업비가 청구됩니다.
- **고객 셀프 수리가 선택 사항인 부품.** 이 부품들도 고객 셀프 수리가 가능하도록 설계되었습니다. 하지만 사용자가 HP에 이 부품의 교체를 요청할 경우 사용자가 구입한 제품에 해당하는 보증 서비스 유형에 따라 추가 비용 없이 교체가 가능할 수 있습니다.

참고: 일부 HP 부품은 고객 셀프 수리가 불가능하도록 설계되었습니다. HP는 만족스러운 고객 보증을 위해 공인 서비스 제공업체를 통해 부품을 교체하도록 하고 있습니다. 이러한 부품들은 Illustrated Parts Catalog에 "No"라고 표시되어 있습니다.

CSR 부품은 재고 상태와 지리적 조건이 허용하는 경우 다음 영업일 납품이 가능하도록 배송이 이루어집니다. 지리적 조건이 허용하는 경우 추가 비용이 청구되는 조건으로 당일 또는 4시간 배송이 가능할 수도 있습니다. 도움이 필요하시면 HP 기술 지원 센터로 전화하십시오. 전문 기술자가 전화로 도움을 줄 것입니다. HP는 결함이 발생한 부품을 HP로 반환해야 하는지 여부를 CSR 교체 부품과 함께 배송된 자료에 지정합니다. 결함이 발생한 부품을 HP로 반환해야 하는 경우에는 지정된 기간 내(통상 영업일 기준 5일)에 HP로 반환해야 합니다. 이 때 결함이 발생한 부품은 제공된 포장 재료에 넣어 관련 설명서와 함께 반환해야 합니다. 결함이 발생한 부품을 반환하지 않는 경우 HP가 교체 부품에 대해 비용을 청구할 수 있습니다. 고객 셀프 수리의 경우, HP는 모든 운송 및 부품 반환 비용을 부담하며 이용할 운송업체 및 택배 서비스를 결정합니다.

HP 고객 셀프 수리 프로그램에 대한 자세한 내용은 가까운 서비스 제공업체에 문의하십시오. 북미 지역의 프로그램에 대해서는 HP 웹 사이트(<http://www.hp.com/go/selfrepair>)를 참조하십시오.

Acronyms and abbreviations

ABEND

abnormal end

ACU

Array Configuration Utility

AMP

Advanced Memory Protection

ASR

Automatic Server Recovery

BBWC

battery-backed write cache

BIOS

Basic Input/Output System

CSA

Canadian Standards Association

CSR

Customer Self Repair

DDR

double data rate

DIMM

dual inline memory module

ECC

error checking and correcting

HTTP

hypertext transfer protocol

IDE

integrated device electronics

IEC

International Electrotechnical Commission

iLO

Integrated Lights-Out

IML

Integrated Management Log

ISEE

Instant Support Enterprise Edition

LED

light-emitting diode

NFPA

National Fire Protection Association

NIC

network interface controller

NMI

non-maskable interrupt

NVRAM

non-volatile memory

ORCA

Option ROM Configuration for Arrays

OS

operating system

PCI

peripheral component interface

PCI Express

Peripheral Component Interconnect Express

PCI-X

peripheral component interconnect extended

PCIe

peripheral component interconnect express

POST

Power-On Self Test

PPM

processor power module

PSP

ProLiant Support Pack

RBSU

ROM-Based Setup Utility

RDP

Rapid Deployment Pack

ROM

read-only memory

SAS

serial attached SCSI

SDRAM

synchronous dynamic RAM

SFF

small form-factor

SIM

Systems Insight Manager

SMTP

Simple Mail Transfer Protocol

SNMP

Simple Network Management Protocol

TMRA

recommended ambient operating temperature

UID

unit identification

UPS

uninterruptible power system

USB

universal serial bus

VCA

Version Control Agent

Index

A

access panel 24, 25
ACU (Array Configuration Utility) 64
additional information 74
ADU (Array Diagnostic Utility) 71
Advanced ECC memory 46
air baffle 25, 26
airflow requirements 32
Altiris eXpress Deployment Server 65
Array Configuration Utility (ACU) 64
Array Diagnostic Utility (ADU) 71
authorized reseller 100
auto-configuration process 63
Automatic Server Recovery (ASR) 66
Autorun menu 62

B

battery 15, 90, 95
battery pack LEDs 19
battery replacement notice 95
beep codes 89
BIOS Serial Console 64
BIOS upgrade 66
BSMI notice 94
buttons 7, 11

C

cable management arm 29, 34, 35
cables 58, 77, 92
cabling 58, 59, 60, 61
cabling, fan board 59
cabling, hard drive backplane 60
cabling, hot-plug SAS hard drive 58
cabling, media drive bay 61
cabling, Systems Insight Display 60
Canadian notice 92
Care Pack 31, 73
cautions 75
CD-ROM drive 50
class A equipment 91
class B equipment 91
CMOS 14

components 7
configuration of system 37, 62
Configuration Replication Utility 63
configuration tools 62
connection problems 77
connectors 7
contacting HP 100
creating a disk image 65
CSR (customer self repair) 100
customer self repair (CSR) 100

D

DC power supply 51
Declaration of Conformity 92
deployment software 65
device numbers 17
diagnosing problems 74, 77
diagnostic tools 62, 65, 66, 70
diagnostics utility 70
DIMM banks, population 47
DIMM installation guidelines 46
DIMM slot locations 14
DIMMs 14, 46, 47
diskette drive 50
diskette image creation 65
drive LEDs 17, 18
drivers 72
DVD/CD-ROM drive, removing 50

E

electrical grounding requirements 33
electrostatic discharge 97
environmental requirements 32
Erase Utility 67
error messages 89
European Union notice 93
expansion board 54, 55
expansion slots 10
external health LED 8
external option blank 35

F

fan board 22

- fan configurations 21
- fan module locations 21
- fans 21
- FCC rating label 91
- features 7
- Federal Communications Commission (FCC)
 - notice 91, 92
- flowcharts 78, 79, 81, 84, 85, 87
- front panel components 7
- front panel LEDs 8

G

- general diagnosis flowchart 79
- grounding methods 97
- grounding requirements 33

H

- hard drive backplane 60
- hard drive bays 7
- hard drive LEDs 17, 18
- hard drives 18
- hard drives, determining status of 18
- hard drives, installing 47
- hardware options 39
- hardware options installation 35, 39
- health driver 66
- hot-plug fans 29
- HP Insight Diagnostics 70
- HP Instant Support Enterprise Edition 71
- HP ProLiant Essentials Foundation Pack 68
- HP ProLiant Essentials Rapid Deployment Pack 65
- HP Systems Insight Manager, overview 68
- HP technical support 100

I

- iLO (Integrated Lights-Out) 67
- iLO 2 (Integrated Lights-Out 2) 67
- iLO 2 activity LED 11
- iLO 2 connector 10
- iLO 2 link LED 10
- IML (Integrated Management Log) 71
- Important Safety Information document 74
- Insight Diagnostics 70
- installation services 31
- installation, server options 35, 39
- installing hardware 39
- installing operating system 37
- installing server 35
- Instant Support Enterprise Edition 71

- Integrated Lights-Out (iLO) 67
- internal health LED 8
- internal USB functionality 70

J

- Japanese notice 94

K

- keyboard connector 10
- Korean notices 94

L

- laser compliance 95
- laser devices 95
- LED, external health 8
- LED, iLO 2 activity 11
- LED, iLO 2 link 11
- LED, internal health 8
- LED, PCI riser cage 18
- LED, system power 8
- LEDs 7
- LEDs, battery pack 19
- LEDs, drive 17, 18
- LEDs, front panel 8
- LEDs, hard drive 17, 18
- LEDs, NIC 11
- LEDs, power supply 11
- LEDs, rear panel 11
- LEDs, SAS hard drive 18
- LEDs, SATA hard drive 18
- LEDs, troubleshooting 74
- LEDs, unit identification (UID) 8, 11
- loose connections 77

M

- Management Agents 68
- management tools 66
- media drive 50
- media drive bay 7
- media drive blank 50
- memory 46
- memory, Advanced ECC 46
- modifications, FCC notice 92
- mouse connector 10

N

- NIC connectors 10
- NIC LEDs 11

NMI jumper 15
NVRAM, clearing 14

O

Online ROM Flash Component Utility 66
Open Services Event Manager 72
operating systems 37, 72
optimum environment 32
Option ROM Configuration for Arrays (ORCA) 65
options installation 35, 39
ORCA (Option ROM Configuration for Arrays) 65
OS boot problems flowchart 85

P

PCI expansion slot definitions 10
PCI riser board 56
PCI riser cage 27
PCI riser cage LED 18
phone numbers 100
POST error messages 89
POST problems flowchart 84
power cord 75, 96
power cord anchor 35
power cord connector 10
power distribution unit (PDU) 33
Power On/Standby button 23, 37
power requirements 33
power supplies 10, 11, 50
power supply LEDs 11
powering down 23
powering up 23, 63
PPM (processor power module) 39
PPM slots 11, 39
preparation procedures 77
problem diagnosis 74
processor 39
processor socket 39
ProLiant Support Pack (PSP) 72
PSPs, overview 72

Q

quick release levers 7, 23

R

rack installation 31
rack mounting hardware 34
rack resources 31
rack stability 75

rack warnings 75
RBSU (ROM-Based Setup Utility) 63
RBSU configuration 63
rear components 10
rear panel connectors 10
rear panel LEDs 11
rear panel, accessing 29
redundant ROM 68
registering the server 38
regulatory compliance notices 91
remote support and analysis tools 71, 72
removing the access panel 24
required information 100
requirements, power 33
requirements, temperature 32
ROM redundancy 68
ROM, updating 66
ROM-Based Setup Utility (RBSU) 63
ROMPaq utility 66, 68

S

safety considerations 74
safety information 68
SAS drive numbers 18
SAS drives 18, 47
SAS hard drive 47, 48, 49
SAS hard drive LEDs 17, 18
SATA hard drive 18
SATA hard drive LEDs 17, 18
scripted installation 62
serial connector 10
serial number 65
server features and options 39
server, installation 35
service notifications 78
shipping carton contents 34
site requirements 32
SmartStart autorun menu 62
SmartStart Scripting Toolkit 62
SmartStart, overview 62
software 62
specifications, environmental 98
specifications, server 98
start diagnosis flowchart 78
static electricity 97
status lights, battery pack 19
StorageWorks Library and Tape Tools (L&TT) 67
support 71, 100
support packs 62
supported operating systems 72

- switches 14, 15
- symbols on equipment 75
- system board battery 95
- system board components 12, 13
- System Erase Utility 67
- system maintenance switch 14, 15
- system power LED 8, 19
- system, keeping current 72
- Systems Insight Display 7
- Systems Insight Manager 68

T

- Taiwan battery recycling notice 95
- technical support 100
- telephone numbers 100
- temperature requirements 32
- Torx screwdriver 10
- troubleshooting 74
- troubleshooting resources 74

U

- UID LED 8, 11, 15
- updating the system ROM 68
- USB connectors 7, 10
- USB support 69
- utilities 62
- utilities, deployment 62, 63, 65

V

- ventilation 32
- video connector 7, 10

W

- warnings 75
- Web-Based Enterprise Service 71